

FERMILAB NEWS

 Fermi National Accelerator Laboratory

Operated by Universities Research Association Inc.
Under Contract with the United States Department of Energy

Vol. 3, No. 18

May 1, 1980

RECYCLING: IMPORTANT PART OF FERMILAB STYLE

"We'll pick up any amount, no matter how small. It all adds up."

And with that flourish, Albert L. Lindner Jr., property management supervisor with Support Services, summed up the important business of recycling at Fermilab. His phone number is Ext. 3585, and more and more people are learning that's the number to call when they want to get rid of items they can no longer use but can be recycled to bring a cash flow back into the Laboratory.

Steel turnings, structural steel (ferrous products more than one-fourth inch thick), sheet iron (ferrous products one-fourth inch thick or less), miscellaneous stainless steel, aluminum pieces and wire, aluminum wire and cable, insulated copper wire and bar (clean), copper wire and cable (insulated) and old batteries are just some of the candidates that the Laboratory sells to vendors to process. Newspapers and computer printout paper and punched cards are the most common paper items the Laboratory recycles.

The other half of the team is Robley Bermel, a materials specialist. Many people have seen him around the site picking up the items to be recycled, processing and sorting them into appropriate categories. He's a real expert at this, said Lindner.

Environmental protection officer representing Support Services, Lindner speaks expertly and with enthusiasm when he says, "We are not wasting some of our natural resources. They are being used again. You can even think of it as coming under the broad category of environmental protection, the utilization of scrap materials."

But that's not all, explained Lindner. By selling the useful scraps to vendors, the Laboratory not only gets money back but also saves money by not having to pay other vendors to haul it away as non-recyclable trash. Last year, the Laboratory salvaged and recycled in excess of \$60,000

W E L C O M E

Fermilab welcomes scientists attending the workshop on "HADRON AND PHOTON PHYSICS AT 1 TeV" today (May 1);

Participants attending the ANNUAL USERS MEETING tomorrow (May 2); and

Members of the HIGH ENERGY PHYSICS ADVISORY PANEL who will be here both of those days.

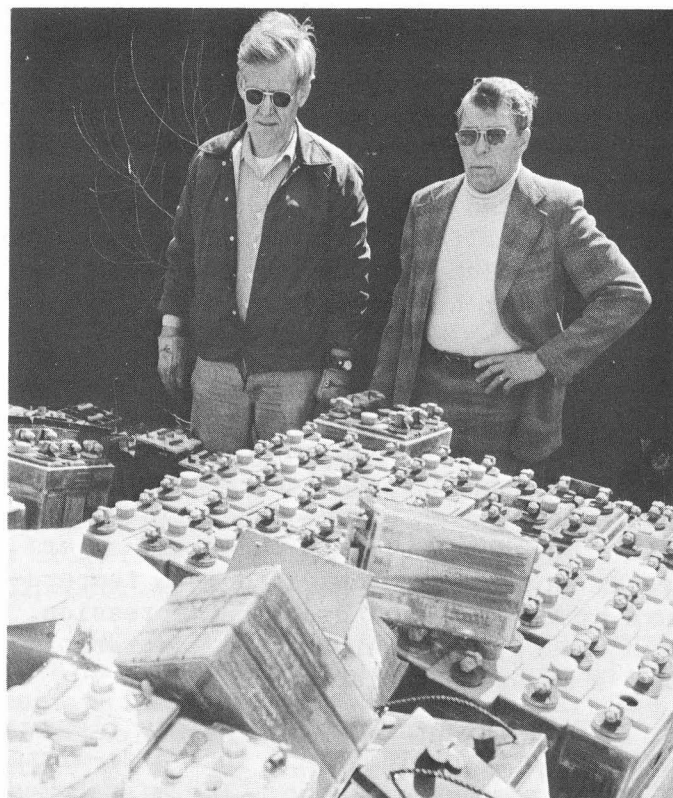

Rob Bermel (left) and Al Lindner examine discarded batteries that will be recycled.

worth of scrap metal, said Lindner. The Laboratory is even interested in the more exotic metals, such as scraps of silver-fox and small amounts of titanium, for example.

But Lindner has more on his mind than just "keeping the environment in the Laboratory looking nice" and cutting down on the expense of removing scraps and trash. "We are providing a real service."

* * * * *

THE STORY CONTINUES

Because of space limitations in its last issue, *FERMINEWS* was unable to give its readers an in-depth look at the Central Helium Liquefier Facility. In the April 24 issue, we described the facility's first success in producing liquid helium. On these pages, we describe the flow process and the control room.

HELIUM FLOW IN LIQUEFIER FACILITY

The flow of helium through the Central Helium Liquefier Facility is by a "closed loop." That is, the helium remains in the system and is constantly recycled.

For example, picking up the flow at A and B in the diagram on this page, it enters the two compressors at one atmosphere of pressure, at room temperature (about 70°F) and with a flow rate of 15,000 standard cubic feet per minute (SCFM). The compressors--the largest in the world at this time being used for helium duty--are Worthington six-cylinder, 4,000-horsepower reciprocating air compressors that have been converted for helium use. A third compressor, already in the facility but not fully assembled, eventually will join its two mates for helium duty.

The helium is cooled in three stages of compression with a cooler after each stage. These large air-cooled heat exchangers--one exchanger system to a compressor--are located next to the compressor but outside the building on the other side of the wall. The gas leaves the heat exchanger system having been cooled to room temperature by removing the heat of compression. (The water jackets around the compressors have a separate cooler.)

From the exchangers, the gas flows back into the building and into a de-mister (C) that removes oil mist. The mist comes from the oil that lubricates the compressors. The helium gas then moves into a large vertical chamber (C) that contains 9,000 pounds of charcoal. Here oil vapor and water vapor are removed as well as other unwanted impurities. The last step in this purification network is called the final filter, a particulate filter that removes substances only a few microns in diameter, like charcoal dust.

Up to this point, the gas has been prepared and processed for entry into what

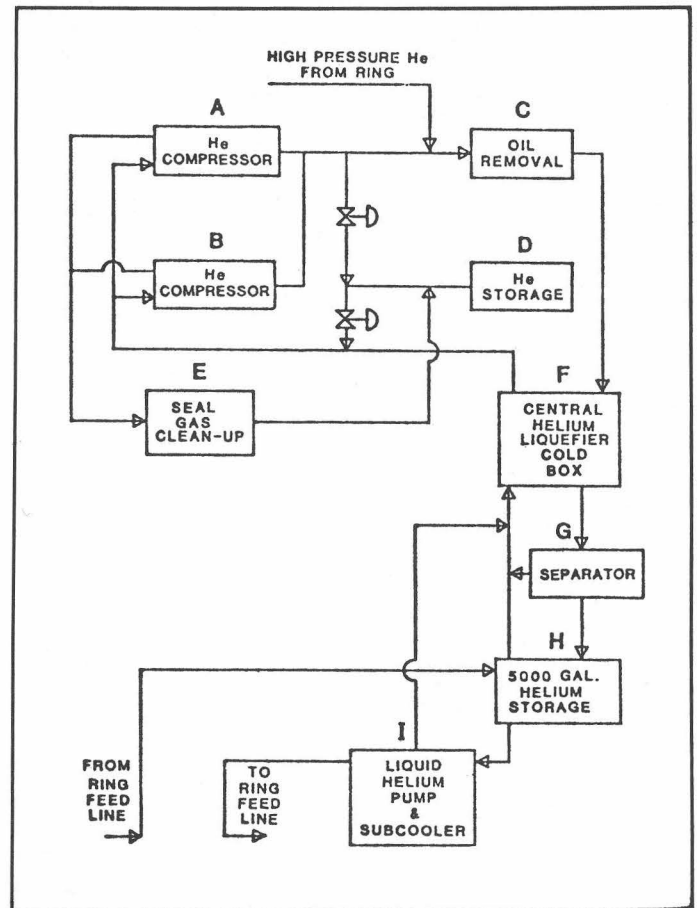

is considered the heart of the facility--the cold box (F). It is in this cold box that the helium, entering at 13 atm. and room temperature, is converted into a liquid.

The cold box, a product of Helix Process Systems, a division of Helix Technology Corporation, Westborough, Mass., is approximately 40 feet tall and 15 feet in diameter. It uses liquid nitrogen pre-cooling techniques and has an efficiency of 22 percent of Carnot. Three turboexpanders manufactured by Sulzer Brothers Limited, Winterthur, Switzerland, produce refrigeration.

Once in the cold box, the helium gas goes through four stages of cooling. In the first step, heat contained in the gas is removed by liquid nitrogen flowing next to it (counterflowing) but in a separate network of tubing. The next three steps are at the turboexpanders (turbines that expand the gas). These expansions reduce the temperature of the gas. The refrigeration thus produced is transferred to the oncoming high pressure stream in the counterflow heat exchanger. The gas exhausting from the turboexpanders is returned to the compression suction stream through the low pressure side of the counterflow heat exchanger.

(Continued on page 3)

(Continued from page 2)

From the final turboexpander, the cold helium, still a gas, flows through a Joule-Thompson valve that suddenly drops the pressure from 13 atm. to 1.4 atm. This loss of pressure (expansion is one way to look at it) and additional loss of heat converts the incoming gas to an outgoing liquid and gas mixture of 1.4 atm. and 4.5°K. The mixture of gas and liquid as it leaves the Joule-Thompson valve is about 50-50.

This mixture is then sent into a 5,000-gallon highly insulated storage tank (H). The 4.5°K helium gas is returned to the cold box where it is used to cool the incoming helium gas (the counterflow process). After taking heat from this incoming gas, the counterflowing gas leaves the cold box at 70°F (room temperature) and returns to the compressors to start the cycle all over again. This returning process is known as refluxing.

While the helium gas is coursing its way through the facility, it is being monitored by a variety of sophisticated analyzers for quality and impurities. These analyzers look for and measure the amount of water, oxygen, hydrocarbons and nitrogen in the helium. The equipment is sensitive enough to measure down to parts per million.

The facility contains another major system. It's a cryogenic purifier that continually removes air from about 7% of the full flow. The purifier is a liquid nitrogen-cooled charcoal trap. Removing air is particularly important when the plant is first started up.

* * * * *

HOW IT ALL BEGAN

Design improvement and cost cutting were two of the major criteria that Fermilab scientists as far back as January 1975 had in mind when they examined "all of our plans for the Energy Saver," explained William B. Fowler, head of the Cryogenic Systems Department of the Energy Saver Division.

They found "a better system (than the one that had been originally conceived) which consisted of a Central Helium Liquefier Facility and 24 satellite refrigerators placed at each service building around the Main Ring," Fowler said.

* * * * *

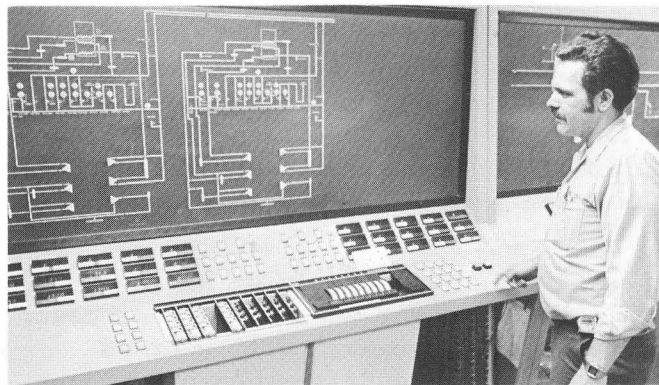

Gary Hodge at control panel.

THE CONTROL ROOM

If the cold box is considered the heart of the Central Helium Liquefier Facility, then certainly the control room would have to be regarded as its brain.

From the control room, located on the second level near the southeast corner of the 50-foot by 180-foot building, the facility's operators can see the cold box to their left and compressors and purification network to their right. The left console of the master control panel monitors the compressors and the right console monitors the cold box.

As much information as possible was centralized in the control room to improve operation as well as debugging. The consoles are rigged to report digitally temperatures, pressures and other variables at key locations throughout the facility. Lighted flow charts in different colors help the operators follow the path of the flowing gas and cooling water throughout the complicated network of tubing and equipment.

Lights and alarms on the control panel also alert operators to variances beyond preset parameters. In some instances, they will be able to make corrections from the control room. In other instances, they will have to go to the site of the problem to make the adjustments. But the panel quickly and accurately alerts them to a problem and tells them where it is located.

The main feature of the control system--the brain within the brain--is a Texas Instruments model 5000 programmable sequencer (a microprocessor) that controls the logic for trips, interlocks, alarms, timers and status displays. The microprocessor evaluates information coming into the control room and tells the data panel what to display.

* * * * *

TREE PLANTING JUST SEVEN DAYS AWAY

With the Batavia High School marching band leading the way, a dedicated group of Fermilab employees and users are expected to follow it from the Central Laboratory to the Meson Area for the 1980 Arbor Day tree planting.

Festivities will begin on May 8 at 11 a.m., May 9 if the weather is inclement. A "distinguished speaker" will address the gathering before it marches off to beautify the Meson Area, according to Jose Poces, a member of the Publicity Committee.

Transportation will be available to and from the planting site. Nearly 90 trees of various sizes and species will be available for planting at selected locations compatible with the landscape.

* * * * *

PROCEEDINGS OF R. R. WILSON SYMPOSIUM STILL AVAILABLE

Copies of "Aesthetics and Science: Proceedings of the International Symposium in Honor of Robert R. Wilson" are still available.

They may be purchased at the ticket sales desk in the atrium of the Central Laboratory at \$20 each. The 130-page volume bound in burgundy-colored leather was published in honor of the Fermilab's director emeritus.

* * * * *

CHEZ LEON MENUS

Tuesday, May 6 - 7:00 p.m. - \$8.00

- Gazpacho
- Paella
- Pineapple Flan

Wednesday, May 7 - 12:30 p.m.- \$4.50

- Shellfish chowder with cheese bread
- Mixed vegetable salad
- Lime sherbet w/melon balls and port

Thursday, May 8 - 7:00 p.m. - \$8.00

- Gnocchi in cream tomato sauce
- Chicken breasts in marsala sauce
- Tomatoes stuffed with spinach
- Fresh green salad
- Peach melba

* * * * *

STOCKROOMS TO CLOSE MAY 12-16

Site stockrooms located in the Central Laboratory and Site 38 warehouse will take annual audited inventories the week of May 12-16.

The Central Laboratory stockroom will close May 12 and 13, while the stockroom at Site 38 will close May 14-16.

"To maintain service continuity, one stockroom will make emergency issues, and I emphasize emergency, while the other undergoes inventory," said Gene Guyer, stores management supervisor. Contact Ext. 3808 for information.

NEW PHONE BOOKS OUT:
TURN IN OLD ONES

Wait, don't throw away that old phone book, said Carolyn Hines, communications service manager.

Fermilab wants to remove the black plastic bindings and use them again, she explained. So when the new phone books with their bright red covers--being distributed this week by the Mail Room--arrive, please give the old phone books to the Mail Room courier, she urged.

* * * * *

REMINDER ABOUT HUMAN VALUES TALK

The next talk in the Fermilab Science and Human Values lecture series will come on May 2.

The lecture by Dr. John H. Neff on "Beyond the Studio: Contemporary Art, the Sciences, and the Artist as Interdisciplinary Man" will begin at 8:30 p.m. in the Central Laboratory auditorium. It is free and open to the public, but because of limited seating, admission is by ticket only. They may be obtained at the ticket sales desk in the atrium or by calling the desk at Ext. 3353.

Neff has been director of the Museum of Contemporary Art in Chicago since March 1978. He is a Matisse scholar and has published and lectured widely on a variety of 19th and 20th century artists and issues.

* * * * *