

ITER-FEAT — Outline Design Report Report by the ITER Director

1.0 Background and Introduction

Six years of joint work under the ITER EDA agreement yielded, by July 1998, a mature design for ITER as presented in the ITER Final Design Report, Cost Review and Safety Analysis (FDR)¹ (the 1998 ITER design), supported by a body of scientific and technological data which both validated that design and established an extensive knowledge base for designs for a next step, reactor-oriented tokamak experiment. The 1998 ITER design fulfilled the overall programmatic objective of ITER - to demonstrate the scientific and technological feasibility of fusion energy for peaceful purposes - and complied with the detailed technical objectives and technical approaches, and cost target adopted by the ITER Parties at the start of the EDA.

When they accepted the FDR report, the ITER Parties, recognising the possibility that they might be unable, for financial reasons, to proceed to the construction of the then foreseen device, established a Special Working Group (SWG)², and charged it with two tasks:

- to *propose technical guidelines for possible changes to the detailed technical objectives and overall technical margins, with a view to establishing option(s) of minimum cost still satisfying the overall programmatic objective of the ITER EDA Agreement, and*
- to *provide information on broader concepts as a basis for its rationale for proposed guidelines, and articulate likely impacts on the development path towards fusion energy.*

In reporting on the first task, the SWG³ proposed revised guidelines for Performance and Testing Requirements, Design Requirements, and Operation Requirements, noting that “*preliminary studies ... suggest that the direct capital costs of ITER can be reduced significantly by targeting the less demanding performance objectives recommended...*” and expressing the view that “*these less demanding performance objectives will satisfy the overall programmatic objectives of the ITER Agreement even though these performance objectives are necessarily less than those that could be achieved with the present [1998] design.*” Consequently, the ITER Council adopted the recommended revised guidelines and asked the Director “*to continue efforts with high priority toward establishing, option(s) of minimum cost aimed at a target of approximately 50% of the direct capital cost of the present design with reduced detailed technical objectives, which would still satisfy the overall programmatic objective of ITER.*”⁴

¹ ITER Final Design Report, Cost Review and Safety Analysis, IC-13 ROD Attachment 6

² IC-13 ROD Attachment 10

³ ITER Special Working Group Report to the ITER Council on Task #1 Results, EIC-1 ROD Attachment 1

⁴ EIC-1 ROD 3.1

In addressing the second task, the SWG reviewed and compared two possible strategies for meeting the programmatic objective of demonstrating the scientific and technological feasibility of fusion, based on:

- an ITER-like machine, capable of addressing both scientific and technological issues in an integrated fashion, and
- a number of complementary lower cost experiments each of which would specialise on scientific/technological issues.

With regard to the second strategy, the SWG⁵ found that the complex non-linear interactions between α -particle heating, confinement barriers and pressure and current profile control, and their compatibility with a divertor can be addressed only in an integrated physics/technology step like an ITER-type experiment, capable of providing long burn in conditions in which α -particles are the dominant source of plasma heating. A satisfactory understanding of these physics/plasma/technology interactions is essential to any reactor-oriented fusion development programme. Moreover the SWG expressed the unanimous opinion that the world programme is “*scientifically and technically ready to take the important ITER step.*”

Given the instruction to address revised technical guidelines from SWG Task 1 and against the programmatic background of the SWG Task 2 conclusions, the main features of ITER design activities since July 1998 has therefore been:

- the study of options for cost reductions against the new, reduced, technical objectives by reducing plasma performance and technical margins, using the advances in physics and technology understandings, and tools arising out of the ITER collaboration to date, and
- the studied convergence towards a specific single design, following newly adopted guidelines.

As a result, it is now possible to define the key elements of a device, referred to as ITER-FEAT. This report provides the results to date of the joint work in the form of an Outline Design Report on the ITER-FEAT design, which, subject to the views of ITER Council and of the Parties, will be the focus of further detailed design work and analysis in order to provide to the Parties a complete and fully integrated engineering design within the framework of the ITER EDA extension.

A companion paper⁶ which documents the Technical Basis to this report was presented to the ITER Technical Advisory Committee for review at its meeting on 20-22 December 1999, in Naka.

⁵ SWG report to the ITER Council on Task #2 Result, ITER Meeting 10-3-1999 ROM Attachment 5

⁶ Technical Basis for the ITER-FEAT Outline Design, Draft for TAC review, 12 December 1999

Plasma Performance

The device should:

- *achieve extended burn in inductively driven plasmas with the ratio of fusion power to auxiliary heating power of at least 10 for a range of operating scenarios and with a duration sufficient to achieve stationary conditions on the timescales characteristic of plasma processes.*
- *aim at demonstrating steady-state operation using non-inductive current drive with the ratio of fusion power to input power for current drive of at least 5.*

In addition, the possibility of controlled ignition should not be precluded.

Engineering Performance and Testing

The device should:

- *demonstrate the availability and integration of technologies essential for a fusion reactor (such as superconducting magnets and remote maintenance);*
- *test components for a future reactor (such as systems to exhaust power and particles from the plasma);*
- *Test tritium breeding module concepts that would lead in a future reactor to tritium self-sufficiency, the extraction of high grade heat, and electricity production.*

Design Requirements

- *Engineering choices and design solutions should be adopted which implement the above performance requirements and make maximum appropriate use of existing R&D database (technology and physics) developed for ITER.*
- *The choice of machine parameters should be consistent with margins that give confidence in achieving the required plasma and engineering performance in accordance with physics design rules documented and agreed upon by the ITER Physics Expert Groups.*
- *The design should be capable of supporting advanced modes of plasma operation under investigation in existing experiments, and should permit a wide operating parameter space to allow for optimising plasma performance.*
- *The design should be confirmed by the scientific and technological database available at the end of the EDA.*
- *In order to satisfy the above plasma performance requirements an inductive flat-top capability during burn of 300 to 500 s, under nominal operating conditions, should be provided.*
- *In order to limit the fatigue of components, operation should be limited to a few 10s of thousands of pulses*
- *In view of the goal of demonstrating steady-state operation using non-inductive current drive in reactor-relevant regimes, the machine design should be able to support equilibria with high bootstrap current fraction and plasma heating dominated by alpha particles.*
- *To carry out nuclear and high heat flux component testing relevant to a future fusion reactor, the engineering requirements are*
 - Average neutron flux 0.5 MW/m²*
 - Average neutron fluence 0.3 MWa/m²*
- *The option for later installation of a tritium breeding blanket on the outboard of the device should not be precluded.*
- *The engineering design choices should be made with the objective of achieving the minimum cost device that meets all the stated requirements.*

Operation Requirements

- The operation should address the issues of burning plasma, steady state operation and improved modes of confinement, and testing of blanket modules.*
- *Burning plasma experiments will address confinement, stability, exhaust of helium ash, and impurity control in plasmas dominated by alpha particle heating.*
 - *Steady state experiments will address issues of non-inductive current drive and other means for profile and burn control and for achieving improved modes of confinement and stability.*
 - *Operating modes should be determined having sufficient reliability for nuclear testing. Provision should be made for low-fluence functional tests of blanket modules to be conducted early in the experimental programme. Higher fluence nuclear tests will be mainly dedicated to DEMO-relevant blanket modules in the above flux and fluence conditions.*
 - *In order to execute this program, the device is anticipated to operate over an approximately 20 year period. Planning for operation must provide for an adequate tritium supply. It is assumed that there will be an adequate supply from external sources throughout the operational life.*

2.0 Revised Objectives

The revised performance specifications adopted by the ITER Council which are set out in full in the above Table, require, in summary:

- to achieve extended burn in inductive operation with $Q \geq 10$, not precluding ignition, with an inductive burn duration between 300 and 500 s, a 14 MeV average neutron wall load $\geq 0.5 \text{ MW/m}^2$, and a fluence $\geq 0.3 \text{ MWa/m}^2$;
- to aim at demonstrating steady-state operation using non-inductive current drive with $Q \geq 5$;
- to use, as far as possible, technical solutions and concepts developed and qualified during the EDA;
- to target about 50% of the direct capital cost of the 1998 ITER design with particular attention devoted to cash flow.

3.0 The approach to an Outline Design

System Studies

As a first approach to identifying designs that might meet the revised objectives, system codes were used which summarise in quantitative form the inter-relationships among the main plasma parameters, physics design constraints and engineering features, and can be combined with costing algorithms.

Such an analysis combines a detailed plasma power balance and boundaries for the plasma operating window, providing the required range of Q for the DT burn, with engineering concepts and limits. Four key parameters — aspect ratio, peak toroidal field, elongation, and burn flux — are intimately linked, allowing options in the systems analysis to be characterised principally by the aspect ratio (A), in addition to the device size, given by the major radius (R). Access to the plasma (e.g. for heating systems) and allowable elongation (simultaneously constrained by plasma vertical position and shape control and by the necessary neutron shield thickness), are functions of aspect ratio.

On this basis the system studies indicated a domain of feasible design space, with aspect ratios in the range 2.5 to 3.5 and a major radius around 6 m, able to meet the reduced requirements, with a shallow cost minimum across the range. The shallowness of the cost curve and the inevitable approximate nature of the system studies made it clear that no particular choice can be made on the optimal aspect ratio based on estimated costs alone. In addition, there are other important aspects whose cost or performance impact may not be easily factored into a systems optimization.

Study of representative options

In order to provide a basis for rigorous exploration and quantification of the issues and costings, representative options that span an appropriate range of aspect ratio and magnetic field were selected for further elaboration and more comprehensive consideration, as reported to the ITER meeting in Cadarache, March 1999⁷.

⁷ Study of Options for the Reduced Technical Objectives/Reduced Cost (RTO/RC) ITER, (ROM 1999-03-10 Attachment 8)

The development of specific representative options provided a more tangible appreciation of the key issues and a practical framework for the process of convergence was explored and clarified in a joint JCT/Home Team “Concept Improvement Task Force” constituted in April 1999, following the guiding principles:

- to preserve as far as possible physics performance and margins against the revised targets, and the scope for experimental flexibility, within the cost target and relevant engineering constraints;
- to exploit the recent advances in understanding of key physics and engineering issues to be drawn from the results of the ITER voluntary physics programme and the large technology R&D projects;
- to maintain the priority given to safety and environmental characteristics, using the principles, analyses and tools developed through ITER collaboration to date.

The Task Force recommendations, presented to the Programme Directors’ Meeting in Grenoble (July 1999)⁸, were instrumental in developing consensus on the criteria and rationale for the selection of major parameters and concepts as the precursor to converging and integrating the various considerations into a single coherent outline design.

Intensive joint work through a JCT/Home Teams “Integration Task Force”, has led to a single configuration for the ITER-FEAT design which represents an appropriate balance of the key technical factors and the cost target and the use of the conservative option for the energy confinement scaling.

⁸ Study of options for the RTO/RC ITER, Director’s Progress Report, ITER Meeting, Grenoble July 1999.

4.0 ITER-FEAT Parameters and Design Overview

The main parameters and overall dimensions of the ITER-FEAT plasma are summarised in Table 4.1 below. The figures show parameters and dimensions for nominal operation; figures in brackets represent maximum values obtaining in specific limiting conditions, including, in some cases, additional capital expenditures:

Table 4.1 Main Parameters and dimensions of ITER-FEAT plasma

Total fusion power	500 MW (700 MW)
Q — fusion power/auxiliary heating power	10
Average neutron wall loading	0.57 MW/m ² (0.8 MW/m ²)
Plasma inductive burn time	≥ 300 s.
Plasma major radius	6.2 m
Plasma minor radius	2.0 m
Plasma current (I _p)	15 MA (17 MA)
Vertical elongation @ 95% flux surface/separatrix	1.70/1.85
Triangularity @ 95% flux surface/separatrix	0.33/0.49
Safety factor @ 95% flux surface	3.0
Toroidal field @ 6.2 m radius	5.3 T
Plasma volume	837 m ³
Plasma surface	678 m ²
Installed auxiliary heating/current drive power	73 MW (100 MW)

The ITER-FEAT facility comprises the following systems:

- the tokamak itself, consisting of a vacuum vessel and its internal components, a blanket and divertor, and superconducting magnets and associated structure);
- a cryoplant and cryodistribution;
- a pulsed electrical power supply;
- a cryostat and its associated thermal shields;
- a fuelling and exhaust system including an exhaust tritium processing system;
- a cooling water system;
- a plasma measurement (diagnostic) system;
- a heating and current drive system and its electrical power supply;
- buildings and services;

The initial assembly of the tokamak and its remote maintenance are also important elements of the ITER-FEAT design.

A cross-section of the tokamak showing the vacuum vessel, its internal components and its ports, as well as some features of the magnet system and cryostat, is shown in Figure 4.1. Figure 4.2 shows an overall schematic of systems important for normal operation, and Figure 4.3 shows an indicative site layout for the entire ITER-FEAT facility.

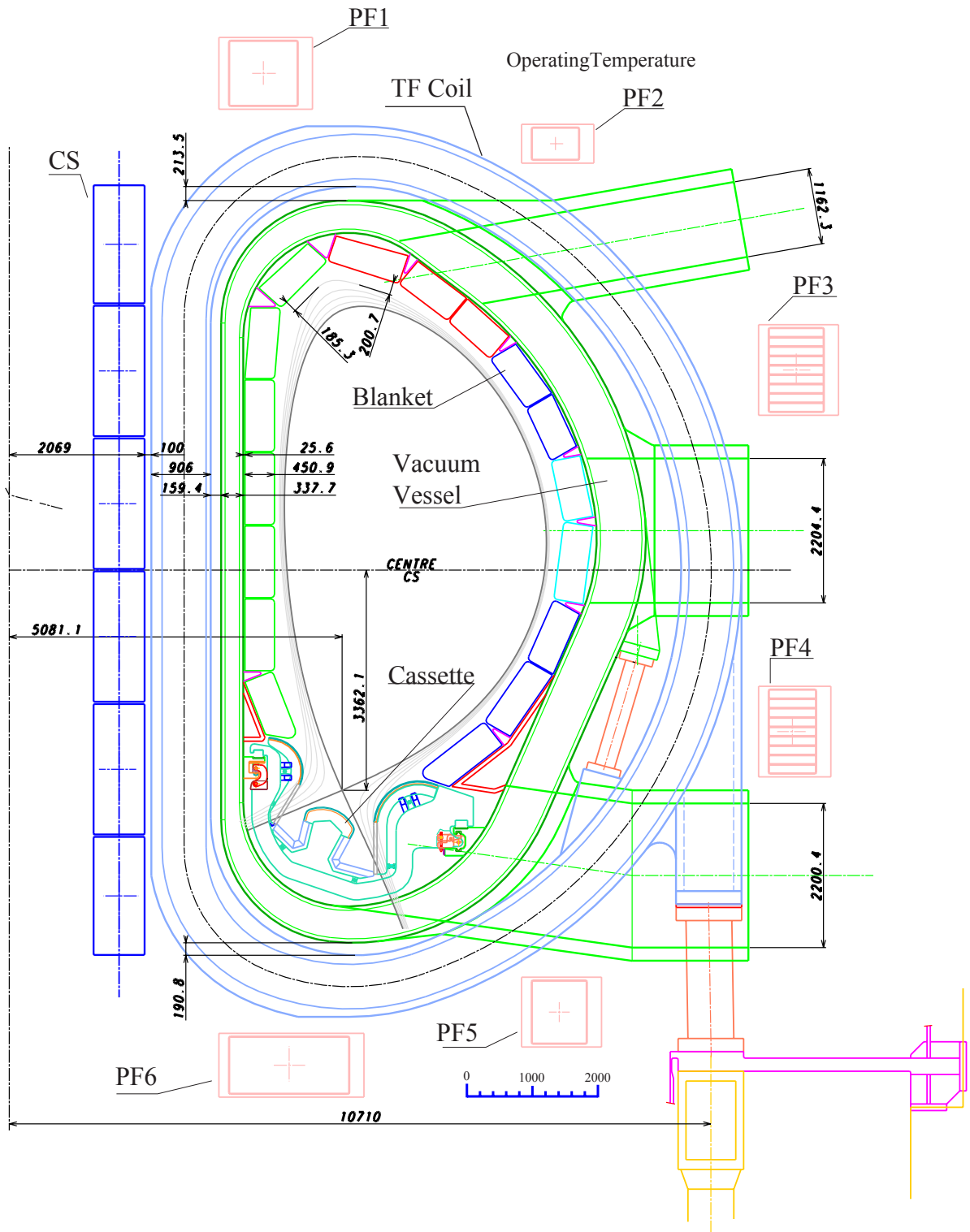

Figure 4.1 Cross-section of the ITER-FEAT tokamak

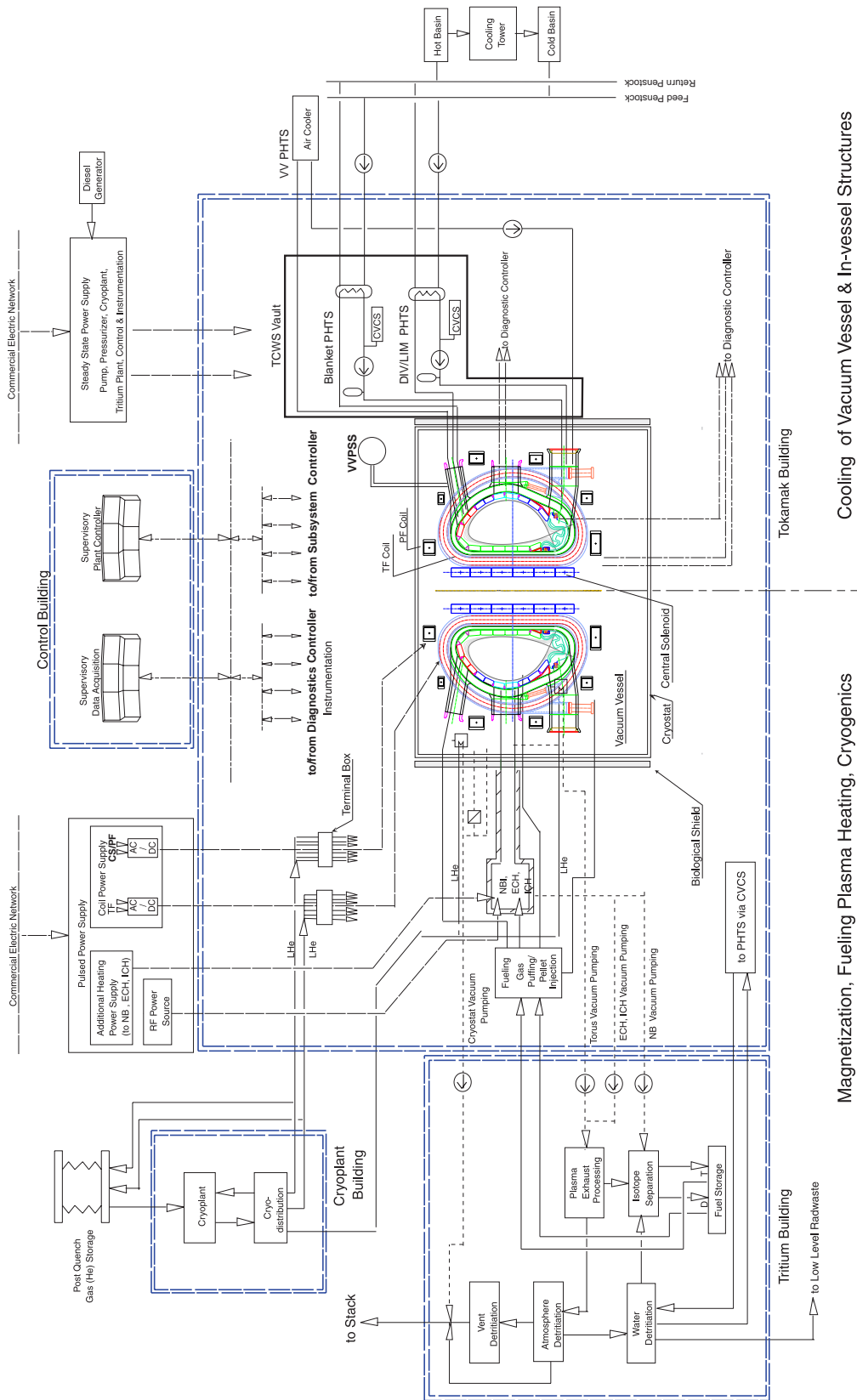

Figure 4.2 ITER-Feat plant systems diagram

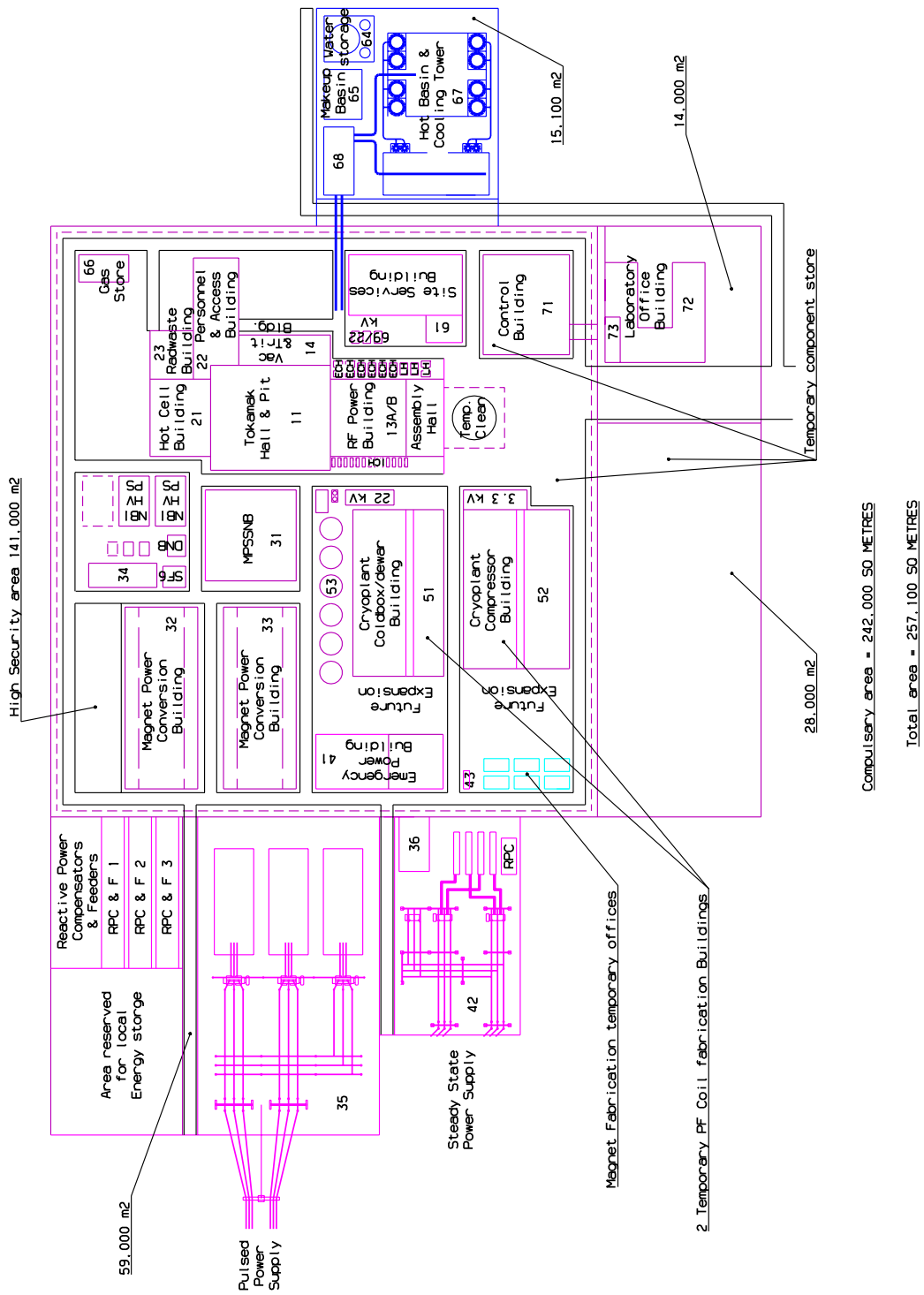

Figure 4.3 ITER-FEAT site and facilities layout

5.0 Physics basis and Plasma performance projections

Overview

The principal physics goals of ITER-FEAT are:

- (i) to achieve extended burn in inductively driven plasmas with the ratio of fusion power to auxiliary heating power (Q) of at least 10 for a range of operating scenarios and with a duration sufficient to achieve stationary conditions on the timescales characteristic of plasma processes;
- (ii) to aim at demonstrating steady-state operation using non-inductive current drive with a ratio of fusion power to input power for current drive of at least 5.

In addition, the possibility of higher Q operation will be explored if favourable confinement conditions can be achieved.

The reference operating scenario for ITER-FEAT inductive operation is the ELMy H-mode and the rules and methodologies for projection of plasma performance to the ITER scale are those established in the ITER Physics Basis (IPB)⁹, which has been developed from broadly-based experimental and modelling activities within the magnetic fusion programmes of the ITER Parties.

The key physics issues relating to plasma performance in the ELMy H-mode regime are:

- the maintenance of H-mode quality confinement at sufficiently high density, achieving adequate plasma β to produce the requisite fusion power, and hence Q value;
- the provision of satisfactory power and particle exhaust to ensure acceptable levels of helium and plasma impurities;
- the evolution of plasma confinement phenomena scaling with size;
- efficient transfer of α -particle power to the thermal plasma while limiting anomalous α -particle losses, via TF ripple or collective instabilities, to prevent damage to the plasma-facing components.

At the same time, global magnetohydrodynamic (mhd) stability and plasma control capability must be such that the thermal and electromagnetic loads, as well as runaway electron currents, arising from disruptions are within acceptable bounds.

H-mode operation at high plasma density is favoured by the choice of a high plasma triangularity and the exploitation of high-field-side ('inside') fuel pellet launch, while the overall choice of design parameters allows considerable headroom for $Q = 10$ operation well below the Greenwald density. Plasma performance predictions show that $Q = 10$ operation can be achieved at modest values of β_N (~ 1.5). However, in the event that the β threshold for the onset of neoclassical tearing modes (NTMs) scales unfavourably with size to ITER-FEAT, stabilization of the modes by localized Electron Cyclotron Current Drive (ECCD) is foreseen.

Extensive divertor model validation and analysis activities performed so far during the EDA give confidence that the proposed divertor design allows adequate power dissipation in

⁹ ITER Physics Basis, ITER Physics Expert Groups et al, Nucl. Fusion, IAEA, Dec 1999

volume to be achieved, with peak time-averaged power loads below the acceptable level of 10 MWm^{-2} , and that the planned fuelling throughput of $200 \text{ Pam}^3\text{s}^{-1}$ will limit the core helium concentration below 6%.

While the detailed evaluation of α -particle loss processes is still in progress, it is expected that the losses via TF ripple can be brought within acceptable limits by reducing the residual TF ripple level via ferromagnetic inserts. In many respects ITER-FEAT represents a key experimental step in the evaluation of α -particle losses due to collective effects at the reactor scale. Nevertheless, on the basis of studies carried out in support of the ITER FDR design, it appears unlikely that excitation of collective mhd instabilities, such as Alfvén eigenmodes, will limit plasma performance in ITER-FEAT inductive scenarios.

The development of plasma operation scenarios that exploit active profile control to access enhanced confinement regimes, which has occurred in the course of the EDA, has allowed greater emphasis to be placed on the use of such scenarios in ITER-FEAT. In particular, these regimes offer the prospect of establishing reactor-relevant steady-state operation in which a significant fraction of the plasma current is generated via the bootstrap effect. Flexibility in the ITER-FEAT design through plasma shaping, a mixture of heating and current drive systems, and mhd stability control techniques for NTMs and resistive wall modes (RWMs), favours the exploitation of plasma scenarios with either shallow monotonic or negative central shear. Although the precise conditions for the development of internal transport barriers (ITBs) are uncertain, the aim has been to provide ITER-FEAT with the necessary plasma control tools to facilitate access to such modes of operation. Moreover, sophisticated diagnostics of key profiles such as q , pressure, and rotation will be required to operate with a high level of reliability from the first phase of plasma experiments, and this has been acknowledged in assigning measurement priorities. The question of α -particle losses via TF ripple losses or collective instabilities, is anticipated to be particularly acute in these regimes, and the design of the ferromagnetic inserts will reflect this consideration. Predictions of steady-state operation in ITER-FEAT, therefore, build upon these recent developments and reflect the expectation that considerable further progress can be achieved in the fusion programme in the future to resolve remaining uncertainties.

Physics Basis and Selection of Plasma Parameters

The reference plasma scenario for inductive $Q = 10$ operation, the ELMy H-mode, is a reproducible and robust mode of tokamak operation with a demonstrated long-pulse capability. The essential physics which enters into the prediction of plasma performance in ITER-FEAT derives from the two principal ELMy H-mode scalings, i.e. the H-mode power threshold scaling, which defines the lower boundary of the device operating window in terms of fusion power, and the energy confinement time scaling. The recommended form for the former scaling is,

$$P_{\text{LH}} = 2.84 M^{-1} B_{\text{T}}^{0.82} n_e^{0.58} R^{1.00} a^{0.81} \quad (\text{rms err. } 0.268)$$

in (MW, AMU, T, 10^{20}m^{-3} , m), with M the effective isotopic mass of the plasma fuel. This scaling expression is based on the latest version of the threshold database (DB3) extended with results from recent dedicated H-mode threshold experiments in Alcator C-Mod and in JT-60U, the latter using the new 'W' shaped divertor. For ITER-like devices, this scaling yields an H-mode power threshold prediction which is approximately a factor of 2 lower than that predicted by an earlier version (IPB98(5)). There is, however, evidence from JET and

JT-60U that the heating power should be 1.3-1.5 times higher than the H-mode threshold to obtain a good H-mode confinement. Therefore, a boundary corresponding to $1.3P_{L-H}$ is also taken into account in the analysis of performance.

Thermal energy confinement in the type I ELMy H-mode is described by the IPB98(y,2) scaling,

$$\tau_{E,th}^{IPB98(y,2)} = 0.0562 I_p^{0.93} B_T^{0.15} P^{-0.69} n_e^{0.41} M^{0.19} R^{1.97} \epsilon^{0.58} \kappa_x^{0.78} \quad (\text{rms err. } 0.145)$$

where the units are (s, MA, T, MW, 10^{19}m^{-3} , AMU, m) and the elongation κ_a is defined as $\kappa_a = S_o/(\pi a^2)$ with S_o being the plasma cross-sectional area. A comparison of the H-mode thermal confinement times with the scaling for a subset of ELMy data in the ITER H-mode database is shown in Figure 5.1.

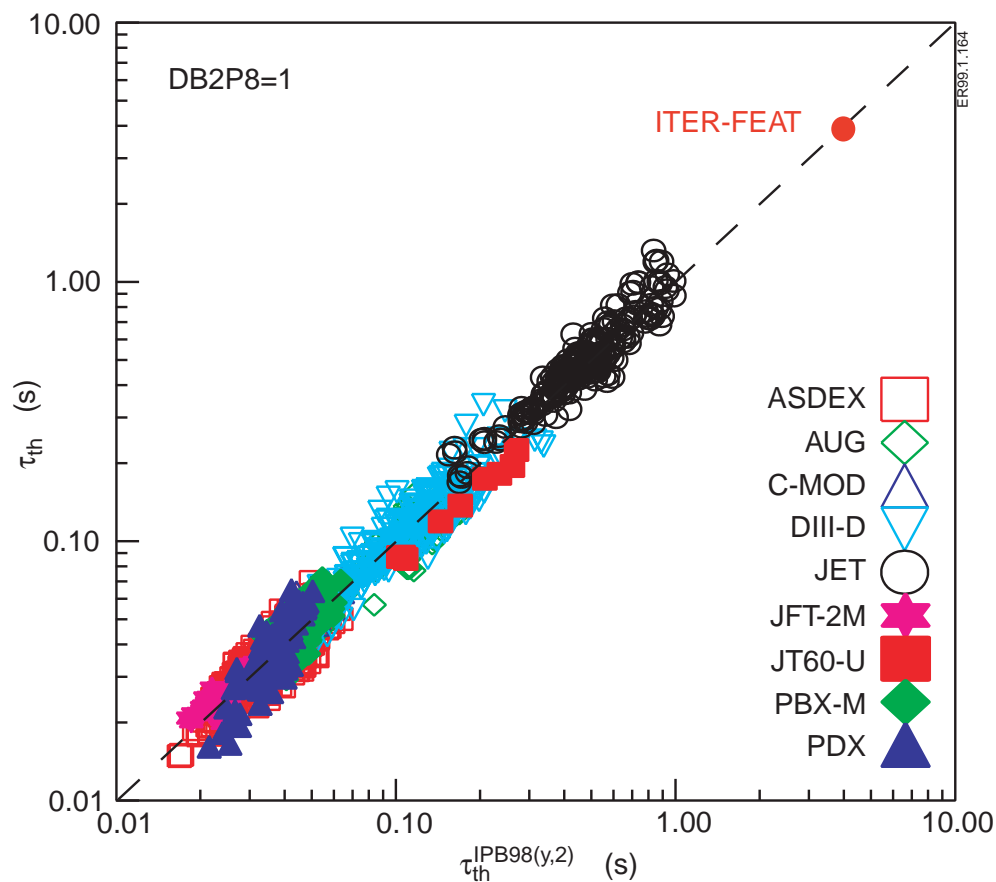

Figure 5.1 Comparison of ELMy H-mode thermal energy confinement times with the scaling expression IPB98(y,2) and scaling prediction for the energy confinement time in a nominal ITER-FEAT $Q = 10$ discharge.

IPB98(y,2) has been selected as a conservative option from among five empirical log-linear (power law) scaling expressions for the energy confinement time reviewed by the Physics Expert Group concerned. Other projections which include the (ohmic) H-mode data from small tokamaks predict $\sim 20\%$ higher confinement for an ITER-like machine.

- The principal mhd stability constraints which contribute to the definition of the device performance relate to the plasma current, elongation, plasma density, and plasma pressure.

1. There is now an extensive energy confinement database for plasmas with $q_{95} \sim 3$, and proven experience in operation with low disruption frequency. A quantitative analysis of disruption frequency on several tokamaks has shown that ITER's goal of achieving an initial disruption frequency of 10% has been attained in existing devices, with no specific problems due to proximity to $q_{95} = 3$. Although recent experiments found no significant degradation of confinement with decreasing q_{95} over the range $2.3 \leq q_{95} \leq 4$, selection of a lower q_{95} operating point would reduce performance margins (particularly for higher Q operation) and might also impair steady-state capability. Therefore, $q_{95} = 3$ has been retained as an acceptable compromise between good energy confinement and satisfactory mhd stability properties although flexibility to accommodate discharges with higher currents ($q_{95} \sim 2.7$) at reduced pulse length is under study.
2. Plasma shaping capability (elongation and triangularity) derives from a consideration of axisymmetric plasma stability and power required to maintain the plasma vertical position, equilibrium control including inner divertor leg length, limits to the acceptable vacuum vessel forces during a vertical displacement event, and the advantages in confinement which may accrue, both from a higher current capability and from direct dependencies of energy confinement on shaping parameters. The range of issues involved in determining the optimum shaping capability has motivated a reassessment of the shaping parameters for ITER-FEAT.

An examination of the H-mode global confinement database confirms that the confinement times from JET and DIII-D are consistent with the IPB98(y,2) scaling up to the highest available values of κ_{95} (~ 1.8 at $q_{95} \leq 3.5$). Nonetheless, in view of studies that show difficulties in maintaining vertical position control within an acceptable range of PF circuit power and coil voltage if only the passive stabilisation of the vacuum vessel and the active stabilisation action of external poloidal field coils are employed, an elongation of $\kappa_{95} = 1.7$ ($\kappa_x \approx 1.84$) has been selected for the reference parameter.

Although there is no explicit dependence of energy confinement time on triangularity, the high triangularity of the ITER-FEAT design ($\delta_{95} \approx 0.33$ or $\delta_x \approx 0.49$) reflects several potential advantages:

- the current-carrying capability of the device, and hence confinement capability, is linked to triangularity through q_{95} ;
- recent results from JET, demonstrate that operation at higher triangularity allows high confinement to be maintained at densities close to the Greenwald value, a result which has been confirmed in ASDEX Upgrade.;
- in steady-state scenarios, where the pressure and current profiles are closely linked, it has been predicted that the β -limit should benefit from higher triangularity.

One possible disadvantage is that the type I ELM frequency is known to decrease with increasing triangularity (increasing edge shear) and the resultant increase in the amplitude of heat pulses which may be produced by lower frequency ELMs is likely to lead to increased erosion of the divertor target.

3. The choice of an aspect ratio of 3:1 is a compromise between the benefits of lower aspect ratio such as lower magnetic field values and a larger margin relative to the H-mode power threshold and those associated with higher ratios such as higher plasma

densities. Practical considerations of accessibility and of maintaining acceptable margins for equilibrium and vertical stability control, also figure in the judgement.

4. The $\beta^2 B^4$ dependence of fusion power motivates operation at the highest attainable β . However, in recent years, neoclassical tearing modes (NTMs) have been shown to limit the achievable $\beta_N (= \beta(\%)/[I_p(\text{MA})/a(\text{m})B(\text{T})])$ in ELMy H-mode plasmas to values below the ideal limit, $\beta_N \sim 3.5$, and this instability might occur in the ITER-FEAT target range of $\beta_N \sim 1.5$ -2.5, leading to degradation of confinement (or disruptions). A stabilization technique for NTMs based on electron cyclotron current drive is, however, yielding promising results on present experiments and its application is foreseen in ITER-FEAT to allow control of such modes if necessary. Nevertheless, the assumption $\beta_N \leq 2.5$ has been taken as a pragmatic limit for calculations of the ITER-FEAT operating window.
5. Optimum use of the plasma pressure for fusion power production implies that densities in the vicinity of (and, in power plants, perhaps beyond) the Greenwald density ($\bar{n}_{\text{GW}}(10^{20} \text{ m}^{-3}) = I_p(\text{MA})/\pi a^2(\text{m})$) be attained. Although it has traditionally been difficult to maintain H-mode confinement at densities close to the Greenwald value, experiments at higher triangularity have obtained H-mode quality confinement at 80% of the Greenwald density. In addition, experiments with inside pellet launch and recent experiments with pumping at both the inboard and outboard divertor strike points have sustained H-mode level confinement at densities beyond the Greenwald value. On the basis of these results, the conservative assumption $\bar{n}_e \leq n_{\text{GW}}$ is used to limit the density range foreseen for the ITER-FEAT reference regime. In addition, as is below, ITER-FEAT can achieve its mission of $Q = 10$ at a normalized density of $n/n_{\text{GW}} \sim 0.6$, and inside pellet launch will be available to facilitate high-density operation.

- Several other physics considerations constrain the operating window of the chosen device. In particular, it has been decided to retain a single-null diverted equilibrium, since the scaling of the H-mode threshold power is more favourable in single null, as opposed to double null, plasmas. Moreover, the difficulty of maintaining a double null equilibrium which is fully up-down symmetric with respect to power handling is likely to impose unrealistic requirements on the accuracy of plasma vertical position control.

- Scrape-off layer and divertor behaviour influences plasma performance in several ways, but the principal issues for ITER-FEAT performance projections are the peak power to the divertor target, plasma helium fraction, and core plasma impurity content. There is substantial experimental evidence that helium exhaust rates are determined by the divertor throughput, rather than by helium transport rates in the bulk plasma, and that $\tau_{\text{He}}^*/\tau_E \sim 5$ can be achieved under relevant plasma conditions with the projected throughput of $200 \text{ Pam}^3\text{s}^{-1}$. This would limit helium fractions in ITER-FEAT to acceptable levels, below 6%.

Domains of inductive operation

Based on the physics considerations and constraints outlined above, and with the major dimensionless geometrical parameters determined, it is possible to identify major radius and plasma current on the basis of the requirement that $Q = 10$ be achieved, that acceptable performance margins can be maintained, and that the projected cost of the device falls within

the required range. Smaller devices are more attractive from the cost point of view, but provide smaller margins for $Q = 10$, lesser likelihood of accessing $Q > 10$ and less flexibility to explore varying modes of operation. Increasing the size increases the operational domain and the margins but at an inevitable increase in cost. The reference parameter set, having a plasma major radius of 6.2 m and plasma current of 15 MA, was selected as it offers a satisfactory margin for $Q \geq 10$ operation, has adequate flexibility and its cost satisfies the target.

Table 5.1. Nominal parameters of ITER-FEAT in inductive operation

Parameter	Units	Reference Q = 10	High Q, high P_{fus}
R/a	m/m	6.2 / 2.00	6.2 / 2.00
Volume	m ³	837	837
Surface	m ²	678	678
Sep.length	m	18.4	18.4
$S_{cross-sect.}$	m ²	21.9	21.9
B_T	T	5.3	5.3
I_p	MA	15.0	17.4
κ_x / δ_x		1.86 / 0.5	1.86 / 0.5
$\kappa_{95} / \delta_{95}$		1.7 / 0.35	1.7 / 0.35
$l_i(3)$		0.86	0.78
V_{loop}	mV	89	98
q_{95}		3.0	2.7
β_N		1.77	1.93
$\langle n_e \rangle$	$10^{19} m^{-3}$	10.14	11.56
n/n_{GW}		0.85	0.84
$\langle T_i \rangle$	keV	8.1	9.1
$\langle T_e \rangle$	keV	8.9	9.9
$\langle \beta_T \rangle$	%	2.5	3.2
β_p		0.67	0.62
P_α	MW	82	120

Parameter	Units	Reference Q = 10	High Q, high P_{fus}
P_{aux}	MW	40	23
P_{ohm}	MW	1.3	1.7
P_{tot}	MW	123	144
P_{brem}	MW	21	29
P_{syn}	MW	8	10
P_{line}	MW	19	20
P_{rad}	MW	48	59
P_{fus}	MW	410	600
P_{sep}/P_{LH}	MW/MW	75/48	84/53
Q		10	24
τ_E, s		3.7	4.1
W_{th}	MJ	325	408
W_{fast}	MJ	25	33
$H_{H-IPB98(y,2)}$		1.0	1.0
τ_α^*/τ_E		5.0	5.0
Z_{eff}		1.65	1.69
$f_{He,axis}$	%	4.1	5.9
$f_{Be,axis}$	%	2.0	2.0
$f_{C,axis}$	%	0.0	0.0
$f_{Ar,axis}$	%	0.12	0.11

Performance calculations using the agreed physics guidelines yield a substantial operating window for $Q \geq 10$ inductive operation for the selected parameter set.

Parameters of two representative plasmas in ITER-FEAT are listed in Table 5.1. The first column shows a reference $Q = 10$ discharge with the nominal plasma current of 15 MA and a fusion power of 400 MW, while the second column tabulates parameters for a regime with higher current, $I_p = 17.4$ MA ($q_{95} \sim 2.6$), that has the potential for a higher Q of ~ 25 and higher fusion power of ~ 600 MW, although with potentially higher risk of plasma disruption. In these simulations, the total power exhausted to the divertor target is held below 30 MW.

To illustrate the range of performance which can be achieved in ITER-FEAT, Figures 5.2 and 5.3 show values of P_{fus} and Q as a function of the auxiliary heating power for discharges with $I_p = 13.1, 15.1$ and 17.4 MA in which an operating point having $H_{H-IPB98(y,2)} = 1$ and $n/n_{GW} = 0.85$ is selected. The minimum fusion power at 15.1 and 13.1 MA is limited by the L-H back transition, taken as $1.3 \times P_{LH}$. There is a strong increase in Q and P_{fus} with the plasma current and a strong increase in Q with reducing the auxiliary heating power. This emphasizes the

fact that the operation space is multidimensional and that plasma parameters can be adjusted to optimize the fusion performance according to whether high Q or high fusion power (e.g. to maximize the neutron wall loading) is required.

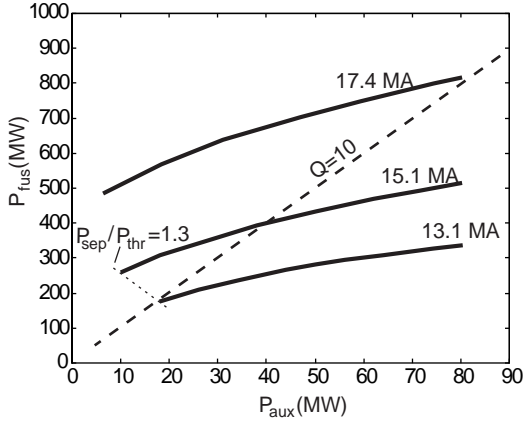

Figure 5.2 P_{fus} as a function of P_{aux} for $I = 13.1, 15.1$ and 17.4 MA at $H_{H-IPB9(y,2)} = 1$ and $n/n_{GW} = 0.85$.

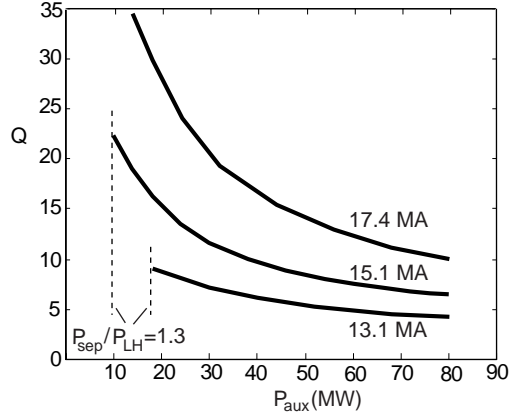

Figure 5.3 Q as a function of P_{aux} for $I = 13.1, 15.1$ and 17.4 MA at $H_{H-IPB9(y,2)} = 1$ and $n/n_{GW} = 0.85$.

A more complete view of the range of plasma parameters at which $Q = 10$ operation is possible can be gained from an analysis of the operational domain in terms of fusion power and confinement enhancement factor, in which the various operational boundaries ($P_{loss} = 1.3P_{LH}$, $n = n_{GW}$, and $\beta_N = 2.5$) can also be traced, as shown in Figure 5.4 and Figure 5.5. Inside the indicated domain the $Q = 10$ is maintained, but the auxiliary power is adjusted together with the density.

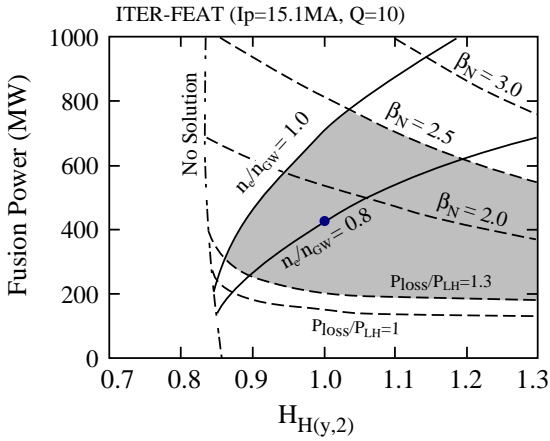

Figure 5.4. $Q = 10$ domain (shaded) for $I_p = 15.1$ MA ($q_{95} = 3.0$).

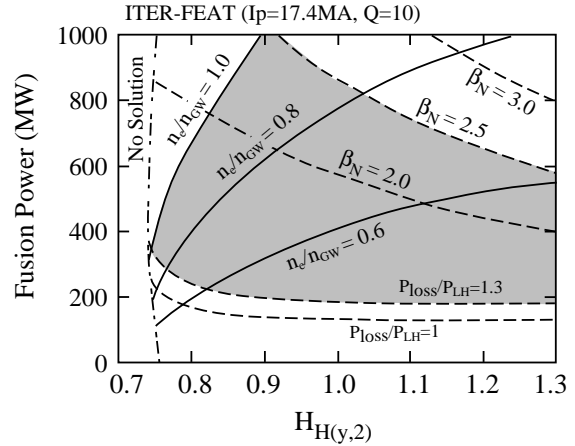

Figure 5.5 $Q = 10$ domain (shaded) for $I_p = 17.4$ MA ($q_{95} = 2.6$).

It is evident from the above, that:

- for operation at $q_{95} = 3$ the fusion output power from the ITER-FEAT design is in the region of 200-600 MW (at $H_{H(y,2)} = 1$), corresponding to a mean separatrix neutron flux ('mean neutron wall loading') of 0.29-0.86 MWm^{-2} , so that the device retains a significant capability for technology studies, such as tests of tritium breeding blanket modules;
- the margin in H-mode threshold power (at $H_{H(y,2)} = 1$) is significantly greater than the predicted uncertainty derived from the scaling;

- the device has a capability for $Q = 10$ operation at $n/n_{GW} \sim 0.6$ and $\beta_N \sim 1.5$ (when $H_{H(y,2)} = 1$).

The results also illustrate the flexibility of the design, its capacity for responding to factors which may degrade confinement while maintaining its goal of extended burn $Q = 10$ operation, and, by implication, its ability to explore higher Q operation as long as energy confinement times consistent with the confinement scaling are maintained.

For instance, Figures 5.6 ($I_p = 15.1$ MA) and 5.7 ($I_p = 17.4$ MA) illustrate the window for higher Q operation ($Q = 50$, representative of ‘controlled ignition’) in ITER-FEAT, showing that controlled ignition is not precluded: operation at a range of Q values is possible and values as high as 50 can be attained if $H_{98(y,2)} \sim 1.2$ is achieved in a improved confinement mode, e.g. reversed shear or shallow shear mode with internal transport barrier, or high density operation can be extended beyond the Greenwald value, or operation at lower q_{95} (~ 2.6) can be sustained without confinement degradation.

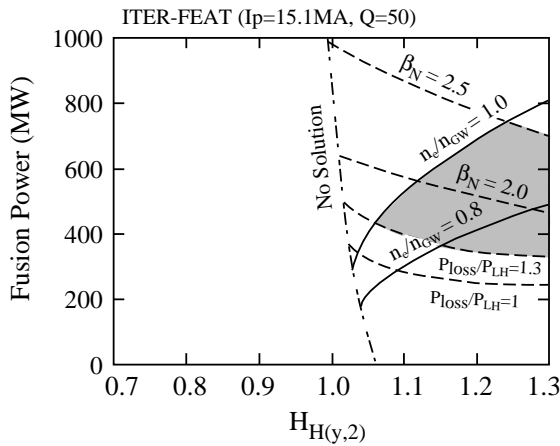

Figure 5.6. $Q = 50$ domain for $I_p = 15.1$ MA ($q_{95} = 3.0$).

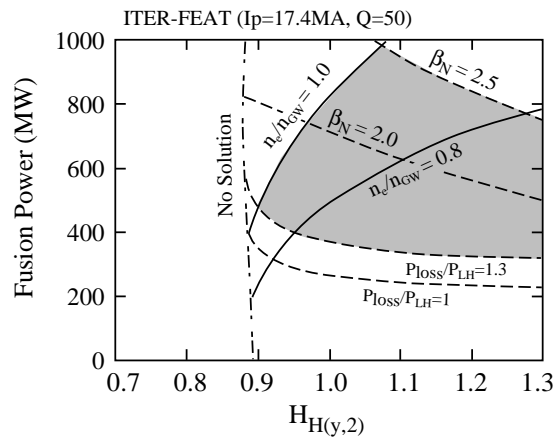

Figure 5.7. $Q = 50$ domain for $I_p = 17.4$ MA ($q_{95} = 2.6$).

Operating Flexibility

The design is capable not only of studying the standard operating regime, but also incorporates the flexibility and extended capability to achieve enhanced performance within the cost constraint. Several aspects of the design address the issue of pressing the boundaries of the operating domain and of accommodating uncertainties in physics predictions. For example, the inclusion of inside pellet launch opens the route towards operation at high density. Moreover, a variety of active feedback control techniques are provided for the stabilization of mhd instabilities. Active current profile control techniques could also provide an additional tool for the control of mhd activity. To extend the achievable range of Q values (and to counteract any unforeseen degradation of confinement), the possibility of operating the device with plasma currents up to ~ 17.4 MA ($q_{95} \sim 2.6$) is being explored, albeit at reduced pulse length (>100 s). Finally, the capability of operation at fusion powers up to 40% higher than the reference value (though under the assumption of no increase in total neutron fluence) is included in the design to enhance the possibility of ignited operation and to accommodate the possibility that higher β values than assumed are achieved.

Steady-state and hybrid operation

A complete scenario for steady-state operation with $Q = 5$ which treats energy confinement plasma profiles, current drive requirements, divertor performance and plasma equilibrium self-consistently, and which satisfies all relevant constraints is yet to be developed. In ITER it is likely that a variety of candidate steady-state modes of operation will be investigated and it is therefore essential that the requisite tools for the control of plasma geometry and profiles are available for on-axis and off-axis current drive capabilities to enable plasmas with shallow or reversed shear configurations to be sustained, in the latter regime simultaneously maintaining the central safety factor well above unity, while the minimum safety factor is held above two; a poloidal field system capable of controlling the more highly shaped plasmas characteristic of high- β_p operation; and methods to allow reliable long pulse operation at high- β , including techniques for the stabilization of neoclassical tearing modes and resistive wall modes.

The capability of the ITER-FEAT designs for steady-state operation with $Q = 5$ are being studied numerically using 0-dimensional analysis within the limitations of current assumptions. Two operational scenarios are under consideration for steady-state operation: high current (12 MA) with monotonic q or shallow shear, and modest current (8 MA) with negative shear. The high current steady-state operation requires all the current drive power (100 MW) available for ITER-FEAT, but the requirements on confinement ($H_H \sim 1.2$) and beta ($\beta_N \sim 3$) are modest. On the other hand, the low current steady-state operation requires more challenging values of confinement improvement $H_H \sim 1.5$ and beta ($\beta_N \sim 3.2-3.5$). Performance predictions for this mode of operation are much less certain than for inductive operation and high current steady-state operation. In particular, the operating space is sensitive to assumptions about current drive efficiency and plasma profiles.

In addition, the potential performance of hybrid modes of operation, in which a substantial fraction of the plasma current is driven by external heating and the bootstrap effect, leading to extension of the burn duration, is being evaluated as a promising route towards establishing true steady-state modes of operation. This form of operation would be well suited to systems engineering tests.

An operation space, in terms of fusion power versus confinement enhancement factor, and showing the transition from hybrid to true steady-state operation is illustrated in Figure 5.8 for $I_p = 12$ MA and $P_{CD} = 100$ MW. Contours of constant n/n_{GW} and β_N are indicated, as is the threshold for $Q = 5$ operation. It is assumed that the plasma minor radius is reduced by shifting the magnetic axis outward. For a given value of fusion power (and hence Q), as the confinement enhancement factor, $H_{IPB98(y,2)}$, increases (simultaneously decreasing plasma density and increasing β_N), the plasma loop voltage falls towards zero. For example, operation with $V_{loop} = 0.02$ V and $I_p = 12$ MA, which corresponds to a flat-top length of 2,500 s, is expected at $H_{IPB98(y,2)} = 1$, $Q = 5$, $n_e/n_{GW} = 0.7$, and $\beta_N = 2.5$. True steady-state operation at $Q = 5$ can be achieved with $H_{IPB98(y,2)} = 1.2$ and $\beta_N = 2.8$. This analysis indicates that a long pulse mode of operation is accessible in ITER-FEAT.

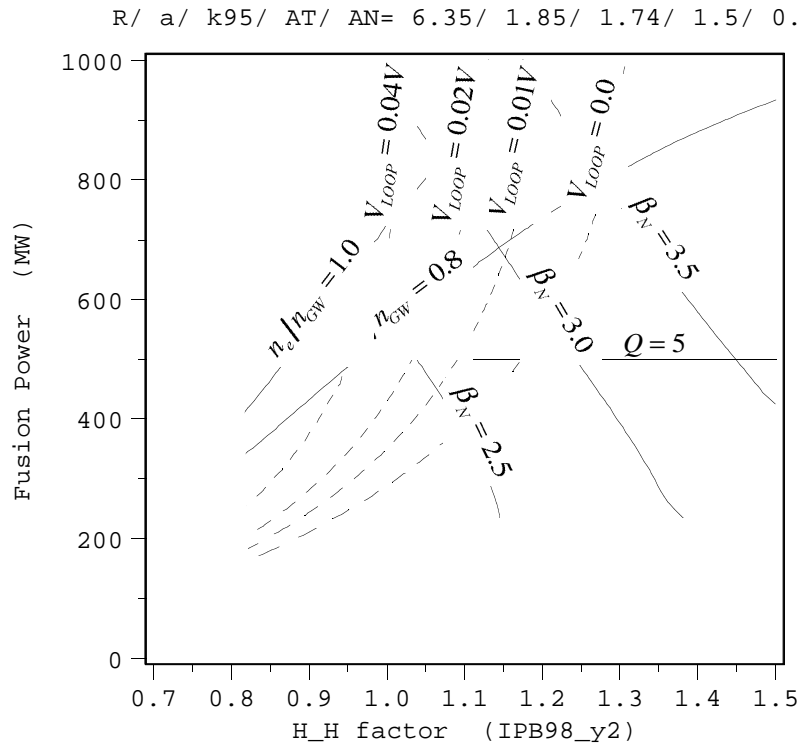

Figure 5.8 Operation space for ITER-FEAT for hybrid (long pulse) and steady-state operation. Here, $I_p = 12$ MA and $P_{CD} = 100$ MW.

Probabilistic Performance Analysis

As with any extrapolation from current experience to unprecedented domains, there are unavoidable ranges of uncertainty on either side of the performance projections for ITER.

To provide an evaluation of the probability of achieving a fusion gain of $Q \geq 10$ in ITER-FEAT, an analysis based only on the estimated uncertainty in the form of the confinement scaling has been developed. This approach does not provide information on, for example, the probability of achieving a specified fluence, since many other factors influencing the average duty cycle and total operational time of the device must be considered.

It is assumed that the energy confinement time (or, in practice, the $H_{H(y,2)}$ factor) for a given set of plasma parameters can be described by a Gaussian distribution having a standard deviation of either 10% or 20% about the mean value. However, for similar discharge conditions, the distribution of $H_{H(y,2)}$ in the database has a smaller spread: for example, with $n_e/n_{GW} \geq 0.65$, $q_{95} \leq 3.5$, $P_{RAD}/P_{HEAT} \leq 0.5$ and $\kappa \geq 1.5$, the spread of $H_{H(y,2)}$ values in the database is only 5%. This illustrates the important point that only a fraction of the scatter in the experimental data is associated with irreproducibility in discharge conditions.

Using conservative operating conditions, it is possible to delineate operation domains for various values of auxiliary heating, which when integrated with the assumed probability density function for H_H , allows to quantify the probability that Q exceeds a given Q_0 value. Combining the analysis for the range of values generates a family of probability curves values that can be used to summarise the overall probability to achieve a target Q value. This analysis is illustrated in Figure 5.9 for the case of $\sigma = 20\%$, and is summarised in Figures 5.10 and 5.11 for $\sigma = 10\%$ and 20% , and for values of plasma current at 15.1 MA and 17.4 MA respectively.

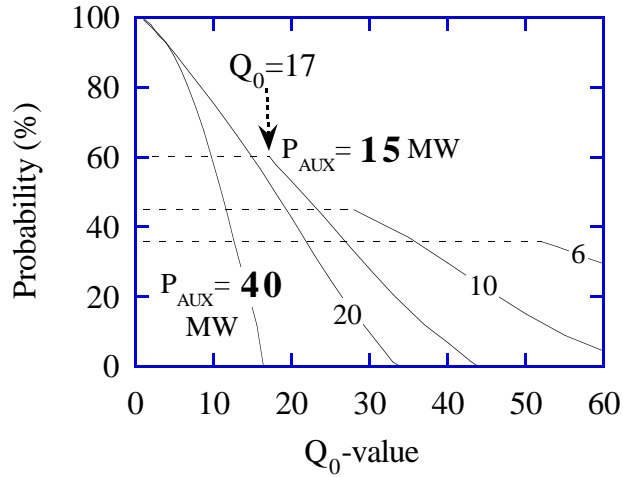

Figure 5.9 Probability of achieving $Q \geq Q_0$ in ELMy H-mode for a range of fixed heating powers, P_{AUX} , when $\sigma = 20\%$. Here $n_e/n_{GW} = 0.85$ and $\beta_N = 2.5$. The flat part of each curve corresponds to $P_{loss} = P_{LH}$ (at $P_{AUX} = 6, 10, 15$ MW). In these cases the probability of $Q \geq Q_0$ is equal to that of $Q \geq Q_{MAX}$, where Q_{MAX} is the value which gives the maximum probability.

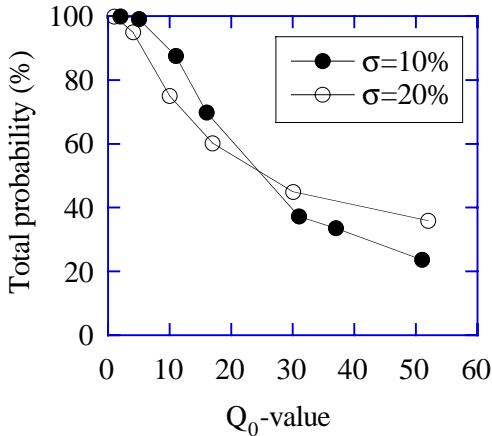

Figure 5.10. Probability of achieving $Q \geq Q_0$ in ELMy H-mode for $\sigma = 10\%$ and 20% with $I_p = 15.1$ MA, $n_e/n_{GW} = 0.85$ and $P_{loss} = P_{LH}$.

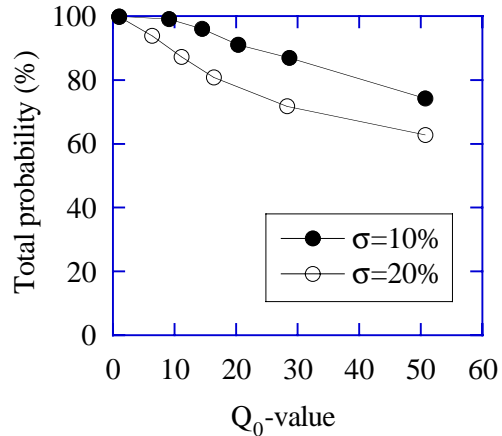

Figure 5.11 Probability of achieving $Q \geq Q_0$ in ELMy H-mode for $\sigma = 10\%$ and 20% with $I_p = 17.4$ MA, $n_e/n_{GW} = 0.85$ and $P_{loss} = P_{LH}$.

On this basis, the probability of achieving $Q \geq 10$ in the ELMy H-mode regime is high. However, if for unexpected reasons $Q \geq 10$ were not achieved under nominal operating conditions, there are, as noted previously, various options for increasing the probability of achieving the required Q . For example, raising the plasma current to 17.4 MA increases the probability of achieving $Q \geq 10$ to $\sim 90\%$ and 100% if $\sigma = 20\%$ and 10% respectively. Another option is to increase the fuel throughput in the divertor beyond the reference value of $200 \text{ Pam}^3\text{s}^{-1}$ to, say, $400 \text{ Pam}^3\text{s}^{-1}$ (which can be maintained for 200 s), allowing the helium concentration to be reduced by 2% (incremental), which, in fusion performance terms, is

equivalent to a 1 MA increase in plasma current. Furthermore, regimes with active profile control could allow enhanced confinement to be accessed in inductive operation.

The probability calculation outlined above is essentially a ‘model’ calculation, i.e. it represents a numerical result based on simple, well-defined assumptions. It does not, however, amount to a complete evaluation of the true probability of achieving $Q \geq 10$. In addition, it is a model calculation carried out in only one dimension of the multi-dimensional operating space which describes a burning plasma and it neither fully reflects the complexity of the behaviour close to operating limits, nor the degree to which experimental optimization of plasma parameters can improve plasma performance. In summary, the optimum operating point of a tokamak plasma consists neither of a random selection of parameters, nor a random response to the operating conditions selected, but corresponds, rather, to a well-defined and reproducible plasma state resulting from extensive experimental development.

Deterministic assessment of performance

As observed above, the uncertainty in extrapolation of the energy confinement time along the scaling law — expressed in a probability distribution of the scalar H_H around a mean value — includes, from a statistical analysis, the consequences on confinement performance from varying machine operating conditions, particularly when their non-dimensional plasma parameters approach their respective limits. As examples, the effect of magnetic shear (from δ, q, κ, A) on confinement in high density discharges, or the effect of saw teeth on low-edge-safety-factor discharges at higher elongation and triangularity are not obviously reflected in the scaling law.

To overcome some of these difficulties, a deterministic procedure has been established so as to define a more focussed experiment, similar in all non-dimensional parameters to a fully documented experiment available in the database from present machines.

- Each discharge from the database is used to size, by means of a system code (in accordance with ITER engineering criteria) a $Q = 10$ machine with the same geometry and parameter values for $\kappa, \delta, A, q_{95}$ and n/n_{GW} as in the experimental case.
- As a first step the extrapolation in the energy confinement time is performed using a ratio to the experimental value coming from the relative values of the parameters not kept constant as follows:

$$\frac{\tau_{E,Q10}}{\tau_{E,Ex}} = \left(\frac{P_{Q10}}{P_{Ex}} \right)^{\gamma_P} \cdot \left(\frac{B_{Q10}}{B_{Ex}} \right)^{\gamma_B} \cdot \left(\frac{R_{Q10}}{R_{Ex}} \right)^{\gamma_R} \cdot \left(\frac{M_{Q10}}{M_{Ex}} \right)^{\gamma_M}$$

From the dimensionally correct IPB98(y,2) scaling law,

$$\gamma_P = -0.69, \quad \gamma_B = 1.49, \quad \gamma_R = 2.49, \quad \gamma_M = 0.19$$

From the more than 1000 discharges in the ELMy H-mode database, only half of them turn out to extrapolate to a $Q = 10$ machine of major radius smaller than 8 m, 70 to a radius smaller than 6.2 m and only a few to radius smaller than 6 m, the smallest value being 5.6 m with $q_{95} = 3.0$.

- As a second step, a more general case is worth considering, which avoids completely the use of empirical scaling formula, the extrapolated device being sized to obtain a required fusion power (and not a Q value) from experimental discharges with the same parameter package as before and, in addition, a fixed value for β_N .

In this case, Figure 5.12 shows the major radius versus the safety factor q_{95} for all machines extrapolated from experimental discharges and capable of 500 MW of fusion

power. A good number of discharges can be extrapolated to 500 MW devices of radius between 6 and 6.2 m (although the relevant values of Q cannot be determined in this case).

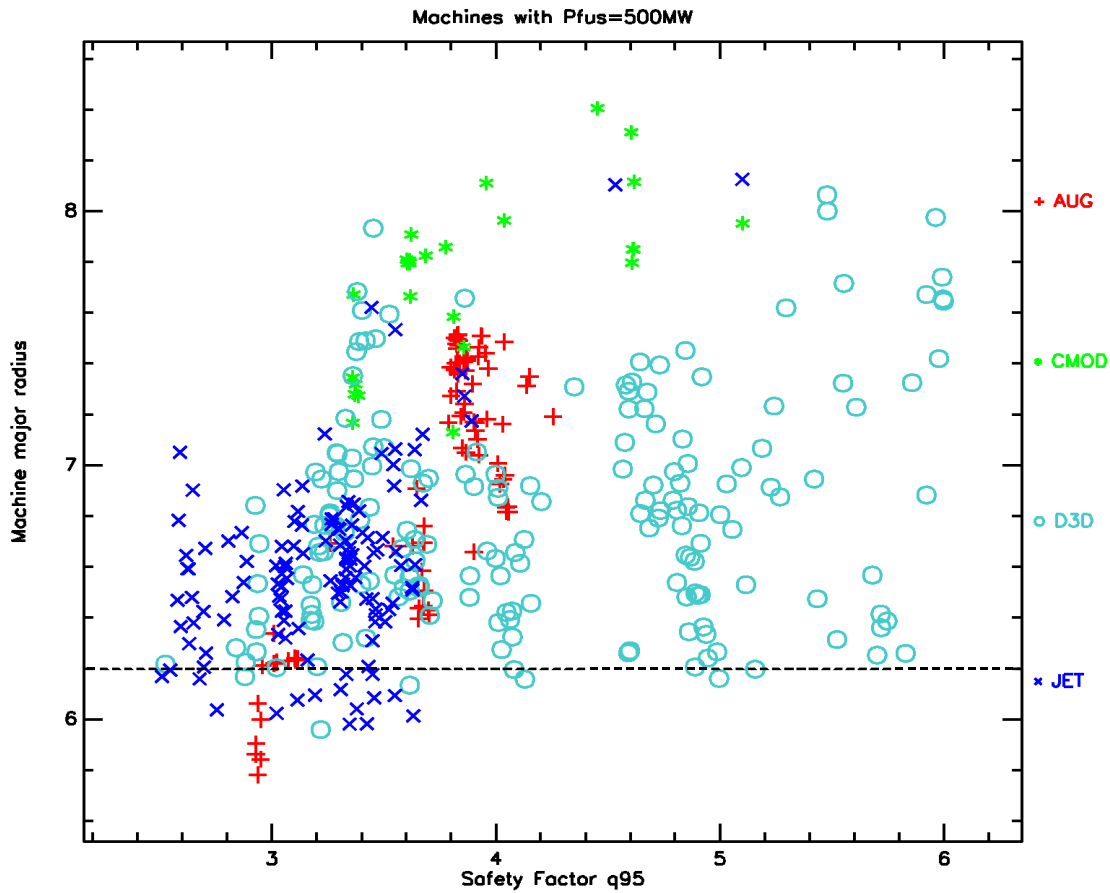

Figure 5.12 Major radius of 500 MW fusion power machines versus safety factor in the database under the assumption of constant beta

In summary, according to this deterministic approach to extrapolation using similar non-dimensional parameters from the documented experimental discharges in present machines (assuming continuity of variation with ρ^* of the physical behaviour of plasma and of radial parameter profiles), the ITER-FEAT design parameters appear adequately chosen to achieve the performance goals, on the basis of extrapolation from many high performance ELMy H-mode discharges from JET, DIII-D and Asdex-U.

6.0 Design Features and Assessments

Summary of design features

Following the revised technical guidelines, the design of ITER-FEAT aims to use as far as possible technical solutions and concepts developed and qualified during the EDA so far. Nonetheless, changes in overall scale and in some physics requirements (e.g. more plasma shaping); the pressure to preserve the plasma performance capacity and flexibility, whilst approaching the 50% cost target ITER-FEAT have induced some significant changes in the design features from the 1998 ITER Design; in addition, the continuing flow of new data from the technology R&D projects have enabled changes in design criteria associated with a better knowledge of the available margins.

The main engineering features and materials in the design are summarised in Table 6.1 At this stage of the development of the design, not all components/subsystems are “frozen”. Nevertheless, all systems which interfere with the global layout of the project have their parameters frozen. Inside some systems with no external influence more than one option is maintained pending further analysis, and, in general, detailed design work and optimisation will lead to limited modifications. As noted above, the proposed engineering design relies mainly on technical solutions which have been or are being qualified by the on-going R&D in the Parties’ laboratories and industries. Most of the remaining issues are related to the choice of options which will provide the largest cost saving through improved and more efficient manufacturing processes.

Because of the unwillingness to compromise with physics extrapolation so as to provide enough margins in the physical parameters and physics-related systems e.g., plasma size, fuelling, and heating and current drive, a major focus of effort will be to press on the manufacturing processes (with their feedback on design) to approach as closely as possible the target of 50% saving in direct capital cost from the 1998 ITER design.

The following paragraphs summarise and assess the key features of the main the ITER-FEAT components and subsystems, and the overall plant systems integration and illustrate some of the issues and options remaining to be decided.

Magnets and structures

The superconducting magnet system which confines, shapes and controls the plasma inside a toroidal vacuum vessel comprises three main systems and their power supplies:

- 18 Toroidal Field (TF) coils which produce the confining/stabilizing toroidal field;
- 6 Poloidal Field (PF) coils which contribute to the plasma positioning and shaping; and
- a Central Solenoid (CS) coil which provides the main contribution to the induction of poloidal field current in the plasma.

Correction coils (including three sets located above, outboard of and below the TF coils) are also required to correct error fields that arise due to imperfections in the actual PF and TF coil configuration and to stabilize the plasma against resistive wall mode instabilities.

The magnet system weighs, in total, about 8,700 t — about one third of the weight of the 1998 design.

Table 6.1 Main engineering features of the ITER-FEAT systems

Superconducting toroidal field coils (18 coils) Superconductor Structure	Nb ₃ Sn in circular stainless steel (SS) jacket in grooved radial plates, or in square SS conductor Pancake wound, in welded SS case wind, react and transfer technology
Superconducting Central Solenoid (CS) Superconductor Structure	Nb ₃ Sn in square Incoloy jacket, or in circular Ti/SS jacket inside SS U-channels Pancake wound, 3 double or 1 hexa-pancake wind react and transfer technology
Superconducting poloidal field coils (PF1-6) Superconductor Structure	NbTi in square SS conduit Double pancakes
Vacuum Vessel (9 sectors) Structure Material	Double-wall welded ribbed shell, with internal shield plates and ferromagnetic inserts SS 316 LN structure, SS 304 with 2% boron shield, SS 430 inserts
First Wall/Blanket (429 modules) Structure Materials	(Initial DT Phase) Single curvature faceted separate FW attached to shielding block which is fixed to vessel Be armour, Cu-alloy heat sink, SS 316 LN structure
Divertor (54 cassettes) Configuration Materials	single null, cast or welded plates, cassettes W alloy and C plasma facing components Copper alloy heat sink, SS 316 LN structure
Cryostat Structure Maximum inner dimensions Material	Ribbed cylinder with flat ends 28 m diameter, 24 m height SS 304L
Heat Transfer Systems (water-cooled) Heat released in the tokamak during nominal pulsed operation	750 MW at 3 and 4.2 MPa water pressure, ~ 120°C
Cryoplant Nominal average He refrig. /liquefac. rate for magnets & divertor cryopumps (4.5K) Nominal cooling capacity of the thermal shields at 80K	55 kW/0.13 kg/s 660 kW
Additional Heating and Current Drive Total injected power Candidate systems	73 MW initially, 100 MW nominal maximum Electron Cyclotron, Ion Cyclotron, Lower Hybrid , Negative Ion Neutral Beam
Electrical Power Supply Pulsed Power supply from grid Total active/reactive power demand Steady-State Power Supply from grid Total active/reactive power demand	500 MW/400 MVar 110 MW/78 MVar

The CS and TF coils use a conductor with a large number of Nb₃Sn strands (~ 1,000), whereas the remaining PF and correction coils use a similar conductor with NbTi strands. All coils are cooled by supercritical helium at ~ 4.5K. The TF coil case is the main structural component of the magnet system and the machine core. The PF coils and vacuum vessel are linked to the TF coils such that all interaction forces are resisted internally in the system thus eliminating the need for large external load transferring structures and the mechanical moments associated with such structures. The TF coil inboard legs are wedged all along their side walls in operation and they are all linked at their two ends to two strong coaxial rings which resist the local de-wedging of those legs under plane loads, a detrimental effect to resist against out of plane loads where these are at their maximum. At the outboard leg, the out-of-plane support is provided by intercoil structures integrated with the TF coil cases. Views of the TF coil case are shown in Figure 6.1.

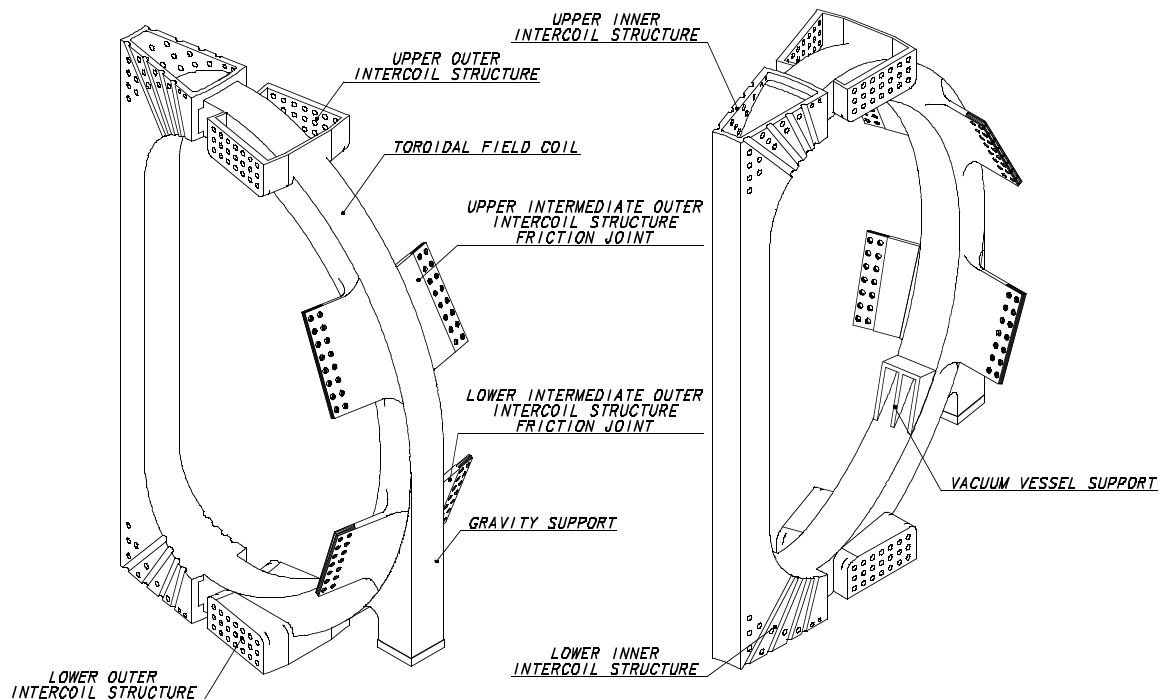

Figure 6.1 3-D views of the TF coil case

A power supply provides the DC coil currents to the different coils from the AC high voltage grid which supplies the ITER-FEAT site. The various coil electrical loads have different characteristics in terms of the currents, power, length of pulse, and so the coil power supply is made up of several subsystems. In addition, protective circuitry is provided to discharge the magnetic energy to external resistors in the possible event of superconducting coils quenching (rapid loss of superconductivity) under certain conditions.

Two options are still under investigation for the TF coil winding: one with a circular conductor embedded in radial plates and the other with a square conductor. The radial plate option has advantages in terms of the insulation reliability and fault detection capability, but suffers from cost and radial build penalties.

For the CS winding, there are two options to provide the structural material which is subject to fatigue due to the large number of pulses. The first one uses an Incoloy square jacket with a co-wound strip and the second one uses two, stainless steel, U-channels welded around a thin circular, jacket made of Incoloy or titanium. The selection of the option has some limited

impact on the CS flux capability but the choice can be postponed until more R&D results are available.

External conditions (static and variable magnetic field, stress and strain levels, cooling etc.) to be met in operation by the TF and CS coil conductors will be simulated in the testing facility built for the CS model coil. Insert coils made of TF and CS conductors will be tested. Results will provide a measure of the margins available around the reference operating point. The model coil programme has also addressed and resolved a number of key manufacturing issues. Production of the CS and TF conductors at industrial scale has been achieved and the “wind react and transfer” process for the conductor has been qualified.

The TF coil case manufacturing issues are being addressed in an R&D programme which includes welding development and the production of large forged pieces and castings as required in the full size coil cases and outer intercoil structures. This development is expected to facilitate manufacture and reduce cost.

In total, the large effort in R&D provides confidence that the remaining issues for the magnet design are not ones of feasibility, but rather, issues which relate to options to reduce the capital cost and to fulfil new requirements for plasma operation (e.g., the segmented CS and wedged TF coils).

For the PF coils, R&D has been initiated to verify the performance of the NbTi conductors for the PF coils; this work has to include the manufacture of a coil with a full size conductor and the testing of this coil in pulsed conditions.

For the main components and subsystems for the magnet power supplies, including AC/DC conversion system, the reference designs are based on existing technology and products available in the world market, or on the progress that is expected to be achieved in the near future.

Cryoplant and Cryodistribution System

Liquid helium from a cryoplant is distributed by a cryodistribution system to auxiliary cold boxes feeding the magnet and other loads as well (e.g. cryopumps for the pumping of the vacuum vessel). Circulating pumps force the flow of supercritical helium through the load in each separate circuit, which exchanges heat with a helium bath, whose pressure (and thus temperature) are controlled by a cold compressor in the return path towards the cryoplant. The plant design has to reconcile the pulsed character of the heat deposited in the magnet coils and the cryopumps, with the steady operation of the cryorefrigerator, which handles only the average heat load.

Although the envisaged cryoplant is a very large and complex facility, the confidence of building such a plant with the required performance is very high since the cryorefrigerator and cryodistribution systems for large particle accelerators provide good bases that can be directly applied to the ITER-FEAT system design.

Cryostat and Thermal Shields

The whole tokamak (vacuum vessel, magnet and associated structures) is located within a single-walled cryostat and within the cryostat there are thermal shields at 80K to prevent the cold portions (~ 4K) from receiving heat from the “hotter” parts. Rectangular bellows made

from elastomer are used to connect the interspace duct wall extensions of the VV ports with the cryostat port to compensate for differential movements.

The design and size of the cryostat are within industrial experience. Provided R&D results confirm the suitability of the intended use of elastomer bellows and Ag-plating to large panels, there is no reason to doubt that the cryostat and thermal shields can be procured and assembled as intended. Should the R&D results be negative, alternative, back-up options are available.

Vacuum Vessel

The double-walled vacuum vessel is lined by modular removable components, including blanket modules composed of a separate first wall mounted on a shield block, divertor cassettes, and diagnostics sensors, as well as port plugs such as the limiter, heating antennae, and test blanket modules. All these removable components are mechanically attached to the VV. These vessel and internal components absorb most of the radiated heat from the plasma and protect the magnet coils from excessive nuclear radiation. This shielding is accomplished by a combination of steel and water, the latter providing the necessary removal of heat from absorbed neutrons. A tight fitting configuration of the VV aids the passive plasma vertical stability and ferromagnetic material in the VV localised under the TF coils reduces the TF ripple. The overall arrangement of one of the 9 vacuum vessel sectors is shown in Figures 6.2 and 6.3.

Integrated functionally with the VV is the vacuum vessel pressure suppression system (VVPSS). This system minimizes the peak pressure inside the vacuum vessel during an in-vessel LOCA by relieving the pressure, caused by the ingress of a water steam mixture from damaged water-cooled, in-vessel components, through rupture discs via pipework into a steam condenser tank.

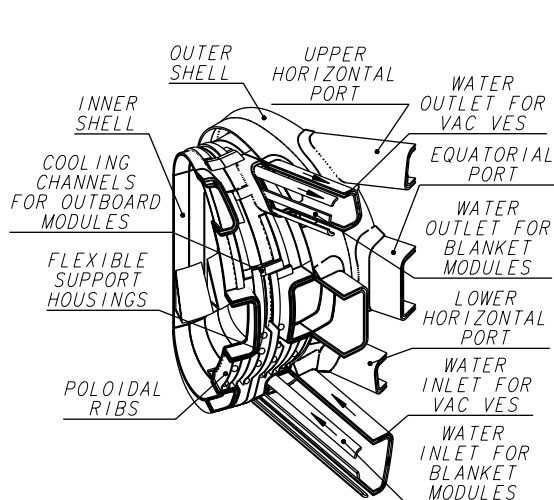

Figure 6.2
Vacuum Vessel overall arrangement

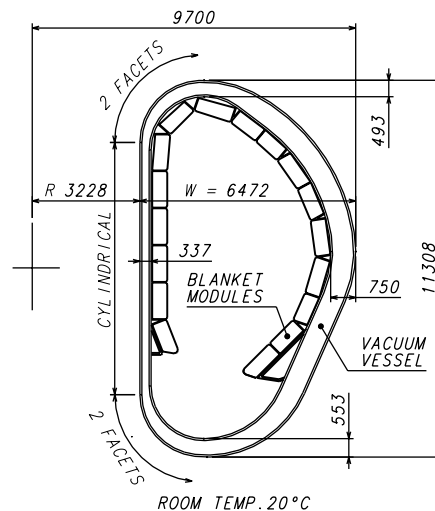

Figure 6.3
Vacuum Vessel cross-section

The manufacture of a full-scale sector of the 1998 ITER design gives a sound basis for the design of the present vessel. To reduce the VV fabrication cost, forging, powder HIPing and/or casting is being investigated for the large number of the housings in the VV for the blanket module support that have a relatively small and simple structure. The preliminary comparison of their fabrication costs with welded structures shows a cost benefit.

Blanket

The blanket system is made up of 429 modules, including those around the Neutral Beam injection lines. The initial blanket acts solely as a neutron shield and tritium breeding experiments are confined to the test blanket modules which can be inserted and withdrawn at radial equatorial ports. The blanket module design consists of a separate faceted first wall (FW) built with a Be armour and a water-cooled copper heat sink attached to a SS shielding block; this minimises radioactive waste and simplifies manufacture.

Two methods are being considered for FW attachment to the shield: a central mechanical attachment, which is bolted to a shield block at its rear side, or a system of bolts (accessed from the first wall) and small shear ribs, to support electro-mechanical loads and to prevent sliding due to thermal expansion.

Two options are being considered for blanket cooling: one with cooling channels integrated inside the vessel structure between the two walls, the other with channels mounted on the vessel in vacuum.

Overall, the manufacture and testing of blanket and FW mockups of the 1998 ITER design gives a sound basis for the present blanket design.

Divertor

The divertor exhausts the helium reaction product of the DT fusion reactions and limits the concentration of impurities (non-hydrogen isotopes) in the plasma by providing a region in which the magnetic field lines just outside the plasma boundary are “diverted” to meet a target plate at a small angle of incidence. Charged particles escaping from the confined plasma will flow to the target, but on the way will lose a large fraction of their energy by radiation and charge exchange with neutrals, thus limiting the power density on the target plate.

The divertor itself is made up of 54 cassettes. Figure 6.4 is a sketch in a poloidal cross-section of the diverted magnetic field and the divertor showing some features of the construction of a cassette, in particular the targets which are the surfaces subjected to the heat load from the diverted particles (peak heat fluxes are less than 20 MW/m^2).

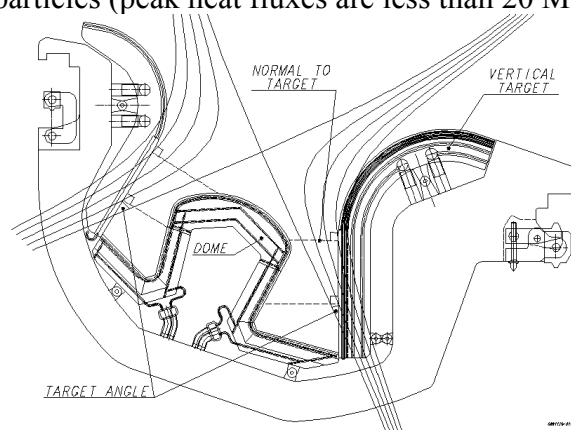

Figure 6.4 Divertor Plasma Facing Components Arrangement

The current design uses carbon at the vertical target strike points. Tungsten is being considered as a backup, and both materials have their advantages and disadvantages. The two options need continuous development so that the best judgement of the relative merits

can be made by the time of procurement. Carbon has the best behaviour to withstand large power density pulses (ELMs, disruptions), but gives rise to tritiated dust. Procedures for the removal of tritium codeposited with carbon and tritiated dust from various components by a number of schemes are under consideration and need further development.

The development of carbon and tungsten armoured plasma facing components has advanced to a level capable of meeting the demanding requirements of the ITER-FEAT divertor for the average target heat load. The armour behaviour against large power density pulses could be the limiting factor. A successful R&D campaign has demonstrated that armoured components can routinely operate with heat loads of up to 20 MW/m² for carbon and > 10 MW/m² for tungsten, with a promise of also reaching 20 MW/m². A prototypical armoured vertical target, which is compatible with the ITER-FEAT divertor requirements, has been built and fully tested. Furthermore, successful operation in tokamaks, with the SOL partially attached to the divertor targets, has demonstrated that the average heat flux to the divertor can be reduced to a value where the armour life-time is adequate. This is the basis for confidence in the design.

Water Cooling system

The heat deposited in the vessel-internal components and the vessel is rejected to the environment via the tokamak cooling water system, which is designed to preclude releases of tritium and activated corrosion products to the environment. Some parts of these heat transfer systems are also used to bake and hence clean the plasma facing surfaces inside the vessel by releasing impurities.

In the worst situation, where all active cooling to in-vessel components is lost because of pipe breaks or power failure, natural convection in the vessel is able to exhaust their decay heat and keep components well below the temperature at which there is no significant chemical reaction between steam (air) and Be-dust.

The normal operation of active components of the water cooling system such as the main pumps, small pumps and motor-operated valves under the operational magnetic field must be guaranteed. The allowable strength of the magnetic field and the required shielding for each component is under study now.

The option of using sea/fresh water instead of forced flow cooling towers as the ultimate heat sink is being considered for a site-specific design. It may be that, in this case, an intermediate cooling water system may be required.

Whilst details of the different elements of the system have yet to be finalised, the general capacity of the main components in the water cooling system is within the industrial experiences (or industrial proven technology), therefore no problematic issues on the component design and manufacturing are expected

Fuel Cycle

The fuelling and pumping system also provides plasma density control. The tokamak fuelling system is capable of gas puffing, and pellet injection from the high field side, into the plasma. These gases are subsequently removed from the plasma together with the helium ash using the torus cryopumps, which exhaust to the tritium plant where impurities are removed from the hydrogen stream and the various isotopes of hydrogen are separated and stored. Tritiated

impurities are processed to lower their tritium content enough to allow their release. The tritium plant also detritiates water, ventilation air and process fluids and solids.

Pellet launch is from the high field side of the tokamak to maximise pellet penetration for a given pellet speed, and fuelling efficiency. However, the pellet speeds required are somewhat beyond those currently achieved without pellet disintegration inside the curved guiding flight tube. Thus R&D is needed to improve the design and geometry of the flight tube.

Regarding the tritium plant, nearly all the separation systems have to be present by the start of DD operation since tritium will be generated during this phase of operation. However systems for water detritiation can be deferred to some extent until full DT operation; for how long needs further quantification.

Many subsystems in the ITER tritium plant are based on proven, industrial processes at relevant scale. In some instances the dynamic nature of ITER operation requires additional confirmation and this is targeted by R&D, e.g., on the isotope separation system and hydrogen storage beds.

Overall there is confidence, that, given the expected outcome of the R&D, the necessary subsystems can be designed, procured and operated as required.

Heating and Current Drive

The plasma heating systems must also have the ability to drive current in the plasma (current drive) to extend the tokamak plasma duration beyond the limitations imposed by the inductive current drive provided by the central solenoid. This lengthening of the tokamak pulse is an attempt to reach “steady-state” conditions where the current drive would be entirely non-inductive. The H&CD systems under consideration for ITER-FEAT are shown in Table 6.2 below:

Table 6.2 Heating and Current Drive Systems

	NB	EC (170 GHz)	ICRF (~ 50 MHz)	LH (5 GHz)
Power injected per unit equatorial port (MW)	16.5	20	20	20
Number of units for the first phase	2	1	1	0
Total power (MW) for the first phase	33	20	20	0
1) Each standard equatorial port can provide 20 MW of RF (EC or IC or LH) 2) The 20 MW of EC module power will be use either i) in 2 upper ports to control neoclassical tearing modes at the $q = 3/2$ and $q = 2$ magnetic surfaces, or ii) in one equatorial port for H&CD mainly in the plasma centre.				

Whilst the designs draw, in general, on existing operational systems, all the options require further R&D to validate the designs and to ensure the performance targets, in the conditions foreseen for ITER. If reasonable R&D programmes are maintained to address the various issues, there is confidence that a range of heating and current drive capacity capable of providing all the requested services can be made available.

Diagnostics

In order to understand the behaviour of the plasma in ITER-FEAT, a large number of special devices (diagnostics) will be applied to the tokamak to measure various properties of the confined plasma, the confining magnetic field and the fusion reaction products. Some of these diagnostics are not only required to evaluate the experiments but are required for machine protection (e.g. to avoid excessive heat loads on vessel-internal surfaces and the consequent damage), and for plasma control (e.g. magnetic field measurements which are required for the control of the plasma shape and position by the PF coils).

For magnetic diagnostics, the lifetime of the in-vessel coils and loops are the important issues. The results of the supporting radiation effects R&D indicate that the necessary lifetime can be achieved.

The ability of the neutron cameras to provide the total fusion power and the alpha particle source profile is directly linked to the available access. A wide angle of view is desirable in both the radial and vertical directions. A view through the intercoil structure for the vertical camera is being considered but the feasibility has yet to be established.

The optical/infrared systems view the plasma with a mirror, and a critical issue is the lifetime of this component. A solution for the mirrors is believed to exist for those systems which operate in the visible and infrared regions. Further work is required for diagnostics which require a relatively large solid angle of observation, for example, active charge exchange recombination spectroscopy and motional Stark effect.

Most of the measurements required for the machine protection and basic plasma control can be made using established techniques. In a few cases, however, novel approaches are required to take account of the expected operating conditions such as intense gamma background.

For sustained operation in high confinement modes, for example reverse shear, it is expected that the profiles of many parameters will have to be brought under active control. Measurements of most of the required profiles can be made but further work is required to confirm that the accuracies and resolutions that can be achieved will be sufficient.

Buildings and Services

The above systems are housed within buildings and structures along with plant services. Table 6.3 lists the main buildings and their footprints and other structures and areas which are required. Considerable effort has been made to make the best use of building space while providing an optimised layout for the required performance of the plant at a minimum cost. The tokamak and its closely associated systems are located mainly in the lower areas of the buildings as illustrated in Figure 6.5 which shows a section through the Tokamak building.

Table 6.3 Site Buildings, Structures and other areas

	Foot Print m²
Tokamak Hall	5,482
Assembly Hall RF Heating Area in Assembly Hall (2,550 m ²)	3,825
Tritium, Hot Cell and Radwaste Buildings, Personnel and Access Control Structure	6,550
Power Supply Buildings	15,264
Cryoplant Buildings	13,950
Site Services, Control and Laboratory Office Buildings, etc	10,861
Building Totals	55,932
Power Supply Areas	59,282
Diesel Fuel, Cryo-Gas, Water and Gas storage, Makeup Basin	3,517
Hot Basin & Cooling Tower, Pumping Yard	9,674
Sub-Total Other Structures and Areas	72,473
Outdoor Storage /Expansion Areas	25,050
Parking Areas	31,410
Roadways	34,684
Sub-total Other outdoor areas	91,144
Grand Total	219,549

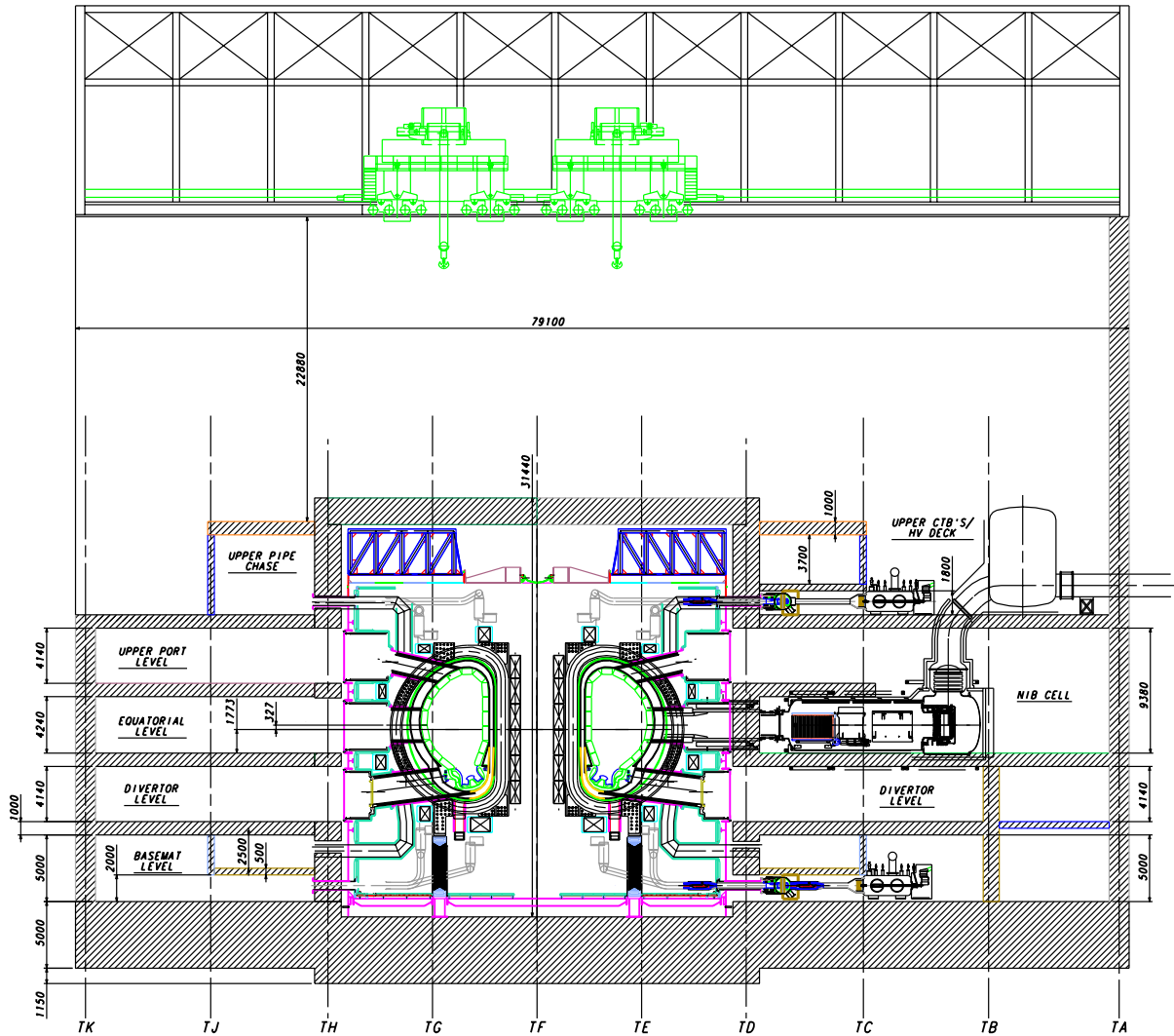

Figure 6.5 Tokamak building north-south section

Although the scale of the buildings and the components is towards the upper end of conventional building and construction experience, there is nothing about the buildings or structures that is outside the realm of current engineering and industrial practice. There are bigger structures, heavier equipment placed, and tighter tolerances used, but not so many all in a single project. Hence, it is an engineering challenge, but well within present engineering and construction capabilities.

Tokamak Maintenance

Because of the production of neutrons in plasmas of deuterium, and of deuterium and tritium, systems near the plasma will become radioactive and will require remote maintenance, with special remote handling equipment. The equipment involves an in-vessel transporter system for the removal and reinstallation of blanket modules, multifunction manipulators for divertor cassette removal, and specialised manipulators to handle vacuum vessel port plugs. Special casks, which dock horizontally to the access ports of the vacuum vessel, are designed to house such equipment and to transport radioactive items from the tokamak to the hot-cell where refurbishment or waste disposal operations can be carried out. Docking of these casks to the vessel and the hot cell flanges is tight, to avoid spreading of contamination. Hands-on assisted maintenance is used wherever justifiable.

A remote handling strategy for ITER has been confirmed by a comprehensive design and R&D programme which has successfully demonstrated that key maintenance operations like blanket and divertor replacement can be achieved using common remote handling technology. Several crucial issues like vacuum vessel remote cutting and re-welding, viewing, materials and components radiation hardness have been addressed and demonstrated. The above strategy is directly applicable to ITER-FEAT.

Some maintenance-related items still need to be addressed. In particular, the possibility of adopting a compact hot cell design based on the possibility to refurbish the divertor cassettes during the maintenance period is being assessed.

Overall, the development programme results so far obtained indicate that the remote maintenance strategy for ITER-FEAT is sound and sufficiently mature to support the ITER programme.

Tokamak Assembly

An outline procedure has been developed for the tokamak assembly, as the basis for determining the assembly schedule, manpower and tooling requirements and the associated cost.

The overall sequence is divided into the following six main sub-sections:

- lower cryostat activities, which cover activities from the initial assembly in this area up to the placement of the first TF/VV/VVTS sector;
- TF/VV/VVTS sub-assembly: Each sector includes a pair of TF coils, a 40° segment of the VV and three VVTS parts, an inboard 40° sector and two outboard, opposite hand 20° sectors.
- integrated TF/VV/VVTS assembly: The sequencing of the TF/VV/VVTS assembly in the cryostat;
- establish magnetic axis: survey procedures to establish the tokamak magnetic datum;
- ex-vessel activities: these activities occur in parallel with the in-vessel assembly procedures;
- in-vessel activities: further activities up to the preparation for commissioning.

A high level assembly plan has been established; details of many assembly activities, and related design of the assembly tooling now remain to be established. The need for a very accurate fit of the mating surfaces between adjacent TF coils may necessitate lengthy and precise matching operations, such as shimming, with a possible significant impact on the assembly schedule if the operations are to be carried out on the ITER site. Concepts and procedures for in-situ surveying and shimming have to be developed.

Plant control system

The integrated control and protection of the entire ITER plant will be achieved by the plant and plasma control system, and an independent interlock system.

The operation of the ITER plant is characterised by five major plant states as outlined below, in which many of the plant subsystems wait for commands before changing to another state, or some subsystems are undergoing maintenance or testing, or are in normal operation. The plant control system controls these states and the transitions between them, which occur through a sequence of steps.

The five defined plant operation states are:

- **Construction and Long-Term Maintenance State (LTM)**, during which most of the tokamak subsystems which require maintenance will be shut down. Typical activities are large in-vessel and ex-vessel component replacement and maintenance.
- **Short-Term Maintenance State (STM)**, for maintenance activities which typically last for 1 to 30 days. In this state, component maintenance and replacement will be carried out mainly outside of the vessel which remains under high vacuum conditions.
- **Test and Conditioning State (TCS)**, during which the tokamak systems are conditioned and heating and other ancillary systems might be tested; no in-vessel or major ex-vessel maintenance may be initiated.
- **Short-Term Standby State (STS)**, which implies that the final preparation of each subsystem is completed and that the plant is ready for plasma operation.
- **Plasma Operation State (POS)**

The control system consists of a centrally-positioned supervisory control system (SCS) and subcontrol systems dedicated to each plant subsystem under the supervision of the SCS. Individual plant and diagnostic subsystems are directly controlled and monitored by their own dedicated intelligent control system. All systems use the same control method of conditional transitions between well-defined sequences of steps to be followed (i.e. SFC - Sequential Functional Control). The SCS controls the transition of the entire ITER plant from one operation state to another, and provides high level commands to plant subsystems, in order to achieve integrated control of the entire plant. The SCS also monitors the operation state of each plant subsystem to ensure it is operating within its proper operational envelope.

The interlock system monitors operational events of the plant, and performs preventive and protective actions to maintain the system components in a safe operating condition. The interlock system is also hierarchically structured and has individual interlock subsystems which are dedicated to each plant subsystem under the central supervisory interlock system.

The control system for ITER-FEAT follows well established principles of system control. Accordingly, no major problems are expected in implementing the design and it has been possible to draw significant conclusions for the safety of the plant, as summarised below.

7.0 Safety and environmental characteristics

Safety Objectives and Design Principles

A main goal of ITER is to demonstrate from the viewpoint of safety the attractiveness of fusion and thereby provide a good precedent for the safety of future fusion power reactors. However, it is necessary to account for the experimental nature of the ITER facility, the related design and material choices, and the fact that not all of them are suited for future fusion power reactors. To accomplish this, ITER safety needs to address the full range of hazards and minimise exposure to these, and to permit siting by any Party.

Detailed safety related principles and environmental criteria have been adopted based conservatively on internationally recognised safety criteria and radiological limits following ICRP and IAEA recommendations and, in particular the ALARA principle.

The following safety objectives are taken into account in setting the requirements that guide the design for ITER-FEAT:

- **General safety:** To protect individuals, society and the environment. To ensure in normal operation that exposure to hazards within the premises and exposure due to any release of hazardous material from the premises are controlled and kept below prescribed limits. To prevent accidents with high confidence, to ensure that the consequences of more frequent events, if any, are minor, and to ensure that the consequences of accidents are bounded and their likelihood is small.
- **No evacuation:** To demonstrate that the favourable safety characteristics of fusion and appropriate safety approaches limit the hazards from internal accidents such that there is, for some countries, technical justification for not needing evacuation of the public.
- **Waste reduction:** To reduce radioactive waste hazards and volumes.

The general principles outlined below both provide direction to guide the design, and provide for on-going, independent review and assessment to ensure the design will meet the safety objectives.

1) Deployment of fusion's safety characteristics

The safety approach is driven by a deployment of fusion's favourable safety characteristics to the maximum extent feasible. Relevant characteristics are:

- the fuel inventory in the plasma is always below 1 g
- plasma burn is terminated inherently when fuelling is stopped due to the limited confinement of the plasma energy and particles
- plasma burn is self-limiting with regard to power excursions
- plasma burn is passively terminated by the ingress of impurities under abnormal conditions (e.g. by evaporation or gas release or by coolant leakage)
- the energy and power densities are low
- the energy inventories are relatively low
- large heat transfer surfaces and big masses exist and are available as heat sinks
- confinement barriers exist and must be leak-tight for operational reasons.

2) Exploitation of the passive safety features

Passive safety, based on natural laws, properties of materials, and internally stored energy are used to help assure ultimate safety margins.

3) Incorporation of defence-in-depth

The ITER safety approach incorporates 'defence-in-depth', the recognised basis for safety technology. All activities are subject to overlapping levels of safety provisions so that a failure at one level would be compensated for by other provisions.

There are three sequential defence levels - 'prevention', 'protection', and 'mitigation'. Defence-in-depth, features at each of the three fundamental levels. All elements of defence in depth have to be available at all times during normal power operation and appropriate elements must be available when power is off (shutdown, maintenance, repair, decommissioning).

4) Provision for the experimental nature of ITER-FEAT

A robust safety envelope is provided to enable flexible experimental usage. Since ITER is the first experimental fusion device on a reactor scale, it will be equipped with a number of 'experimental components', in particular inside the vacuum vessel. In view of uncertain plasma physics and lack of operational experience, the experimental components are designed to allow for the expected loads from plasma transients so as to reduce the demands on systems which are required for safety. In particular, no safety function is assigned to experimental components.

Nevertheless, faults in experimental components that can affect safety are subject to safety assessments. On this basis, related measures will be incorporated in the design as appropriate.

The experimental programmes will be developed in such a way that design modifications will take account of experience from preceding operations and will stay within the safety envelope of the design.

Safety — Review and Assessment

Safety assessments covering normal operation, all categories of accidents, and waste management and disposal are an integral part of the design process, the results of which will be available to assist in the preparation of safety documentation for regulatory approval. The preliminary assessments of the ITER-FEAT design build on and develop further the detailed safety assessment of the 1998 ITER design.

Normal Operation

Effluents

Operational effluents are expected to be at a level which would cause public doses to the most exposed individual below 1% of the natural radiation background (postulating a typical 'generic' site).

Most releases are expected during maintenance operations. Presently available assessments suggest that the total tritium releases from the plant are about 0.25 g per year. In terms of doses, the releases of activation products are comparable to those of tritium.

Occupational Safety

Design criteria for personnel access have been established to ensure an acceptable level of occupational safety. Radiological hazards are being estimated by neutron activation analysis of components and structures, associated gamma transport calculations, and activated corrosion product build-up analysis, to assess against the design criteria. Non-radiological

hazards (EM fields, beryllium, etc) are also being estimated. In addition to meeting the criteria for access, an iterative assessment process will be applied to operational and maintenance activities to reduce radiation exposure based on the ALARA principle.

Radioactive Waste

Activated and contaminated materials arise during the operational phases and remain after final shutdown. Not all these materials would need to go into a waste repository, rather after some decay time a significant fraction can be 'cleared', i.e. declared to be no longer radioactive waste. The related processes (e.g. as recommended by IAEA) range from 'unconditional' clearance to clearance 'for recycling'.

A provisional waste characterisation assessment for the ITER-FEAT has been performed although a detailed study cannot be done until the design is finalised (or nearly so). A scaling approach based on the detailed assessment of the 1998 ITER design indicates that the amounts of radioactive material falls by about a half.

Possible accident conditions

In case of accident, ITER-FEAT protects personnel and the public using radioactivity confinement. Sources of tritium or activated materials that occur within the vacuum vessel, in the tokamak cooling water system, in the fuel cycle and within the hot cell, are housed behind multiple physical and functional barriers, which protect against the spread and release of hazardous materials. The primary confinement barrier is designed to have high reliability to prevent releases. A secondary barrier is provided close to the primary one to limit the spread of contamination and protect personnel from leaks. Exhaust from rooms that can be contaminated is treated by filters and/or detritiation systems, and monitored.

Possible Loss of Coolant Accidents (LOCAs) are accommodated in the design by means of the vacuum vessel pressure suppression system, the various confinement structures, and the detritiation and filtering systems, with the result that the assessed consequences of possible LOCAs are commensurate with the conservative ITER release guidance.

Decay heat densities in ITER-FEAT are so small that no emergency cooling of the in-vessel components is needed. The vacuum vessel cooling system has the capability to passively remove all decay heat via natural circulation. Maximum temperatures of the in-vessel components during accidents are below 330°C with vacuum vessel cooling only. These temperatures are sufficient to radiate the power from the in-vessel components to the vacuum vessel which transports the power to the ultimate heat sink. No significant chemical reactions occur between steam/air and Be-dust at these temperatures. Venting of the cryostat and air convection at the outer cryostat surface limit the maximum temperatures of the in-vessel components to about 350°C without any cooling of the vacuum vessel.

Safety – Conclusions

In recognition of the central importance of the safety and environmental aspects of ITER-FEAT, a rigorous approach is being pursued, by establishing firm and widely recognised safety principles and criteria for the design process against which then to assess the ongoing design work. Building on the comprehensive and detailed safety and environmental analysis undertaken for the 1998 design, the preliminary assessments of ITER-FEAT tends to confirm that the design will meet the project safety objectives and will have, in many respects a reduced overall safety and environmental impact.

8.0 Costs and Schedule

Indicative Cost Estimates

A valid cost estimate of ITER-FEAT will be obtained only after the engineering details have been worked out to provide specifications for an industrial cost analysis to be undertaken by firms of the Parties in the second half of 2000. Pending such analysis, only a rescaling from the costs of the 1998 ITER design can be done as outlined below. However, this simple scaling cannot take into account the improvements in the design and in the industrial fabrication process expected as a result of current design work and supporting analysis and R&D.

For this initial indicative exercise, the 1998 ITER design cost basis was used as fully as possible, retaining the detailed system cost structures developed for that design, with cost scaling being done, as far as reasonable, at the component levels.

All costs are again expressed in the ITER Unit of Account (IUA) defined as \$1000 US in January 1989. The relationship between the IUA and the ITER Parties' currencies in January 1989, and the internal escalation factors to early 1999 are shown in Table 8.1.

Table 8.1 Currency parities in January 1989 and escalation factors to Jan 1999

	IUA	US \$	ECU (Euro)	¥
Jan 1989 exchange rates	1	1000	875.8	127,510
Internal escalation factors	1	1.35	1.4	1.14

In the many cases where the ITER-FEAT systems have retained their basic design features from the 1998 ITER design, cost can be simply scaled down within an unchanged cost structure. For each system the major cost drivers are identified to recalculate the component materials costs, the tooling, the fabrication, assembly, testing and shipping costs.

The amount of materials is typically associated with the number of components and characteristic size or weight. The tooling cost drivers are selected depending on the specific technological procedures used for each system; often these drivers are used with power scaling factors less than 1, typically 0.7. A similar approach is used for recalculating the labour costs associated with fabrication, assembly, testing and shipping.

Some new design options require the adjustment of the previous cost structure and identification of additional cost drivers. Such changes have to be applied, e.g., to the multi-sectional central solenoid, and the vacuum vessel with added back plate functions following elimination of the backplate etc.

The results of this initial scoping for direct capital costs are summarised in Table 8.2 below. The figures show estimates for total system costs; the impact of deferring certain of the costs have yet to be quantified.

Table 8.2 Indicative cost breakdown for ITER-FEAT

Components/systems	Indicative Cost (kIUA)	% of Total
Magnet Systems	880	27
Vacuum Vessel, Blanket & Divertor	507	16
Power Supplies	224	7
Diagnostics	215	6
Other Main Tokamak Systems	664	21
Heating Systems (73 MW total)	229	7
Buildings, Site Facilities and Balance of Plant	503	16
Total Direct Capital Costs	3,222	100

Compared to the cost estimate of the 1998 design, the largest cost savings occur for the Magnet systems and tokamak buildings, where reductions of more than one half are indicated. Cost savings approaching 50% can also be expected for other size-dominated systems such as the Vacuum vessel/Blanket, Divertor, Pulsed Power supply, etc. Lesser savings are indicated for function-dominated systems such as balance of plant and even less for auxiliaries such as fuelling, pumping, tritium plant, cryoplant, remote handling and assembly. No savings are indicated for the diagnostics and CODAC systems.

The net result indicates an overall reduction to about 56% of the estimated direct capital costs of the 1998 design. The scope to approach closer to 50% will be better understood only after the further detailed design and analysis needed to optimise choices and after the Parties' industries will have had the opportunity to study and estimate procurement packages which incorporate expected improvements in design and fabrication process. These are now the most important areas of activity for reducing capital costs further towards the target.

Operating costs depend highly on the cost of electricity (assumed at an average cost of 0.05 IUA/MWh), the salaries of the 200 professionals and 400 support personnel, the cost of the divertor high heat flux component replacements and general maintenance expenses, most of which may vary quite substantially amongst the potential host sites for ITER. Simple scalings from the operating cost estimates for the 1998 ITER design suggest an indicative annual figure of about 180 kIUA over the first ten years of ITER operation — a saving of almost 50%.

The main driver for decommissioning costs included in this estimate is the amount of work necessary to de-activate the machine at the end of the plant operation, remove all in-vessel components and then, after activity decay, finally remove the ex-vessel components and dismantle the vacuum vessel. The required manpower for these operations is scaled according to the size and number of sections of the vacuum vessel, assuming a constant cost for additional equipment envisaged in the 1998 ITER design. The costs of transportation and long term storage of the activated material is not taken into account. On this basis a cost of about 170 kIUA for the assumed decommissioning is indicated - a saving of about 45%.

Schedules

The overall project plan is composed of an eight years construction phase including the commissioning necessary for the first hydrogen plasma discharge, followed by approximately

20 years of machine operation. For illustrative purposes this is divided into four phases: two and half years of hydrogen plasma operation, one and a half years of D operation, 3 years of DT operation to low fluence, and for the remaining time a higher fluence DT operation phase. There may be a one to two year machine modification phase before starting the second DT phase in which the outboard shield blanket can be replaced with a breeding blanket. A three year de-activation phase follows after twenty years of operation. The ITER organization has responsibility up to the end of this phase for the ITER facility, which is then handed over to an organization inside the Host Party for dismantling and disposal processes. Figure 8.1 shows the construction planning and figure 8.2 shows the planning for the first ten years of operation.

Construction Schedule

On the assumption that an appropriate amount of technical work has been completed and that an appropriate ITER organisation comes into operation when an agreement to construct ITER is signed, the start of the actual construction on the site depends upon when a site license or construction license is issued by the regulatory authority of the Host Party. Therefore, the dates in the construction schedule are measured in months from a start date (“T = 0”) defined as the date at which the actual construction work of excavation for the tokamak building is started, immediately after the site license or construction license is issued. Documents required for the formal regulatory process are prepared by the Host Party to allow the regulatory process to start immediately after the signing of the Construction Agreement and to provide a licence after 12-24 months.

As previously, the construction plan is based on “just in time” delivery; the construction planning therefore depends strongly on timely preparations and efficient processing of contracts especially for the long lead-time items and for the critical buildings. A prompt start to the Tokamak Building and to the PF fabrication building (which will later be converted to the two cryopant buildings) are the first steps to the critical path. This presumes that any necessary site preparations will have been completed by the Host before T = 0. The procurement schedules for the superconductor strand, for the TF coils are also critical early actions and it is important to ensure completion of the necessary preparations to launch these procurements.

Fig 8.1 Construction schedule for ITER-FEAT

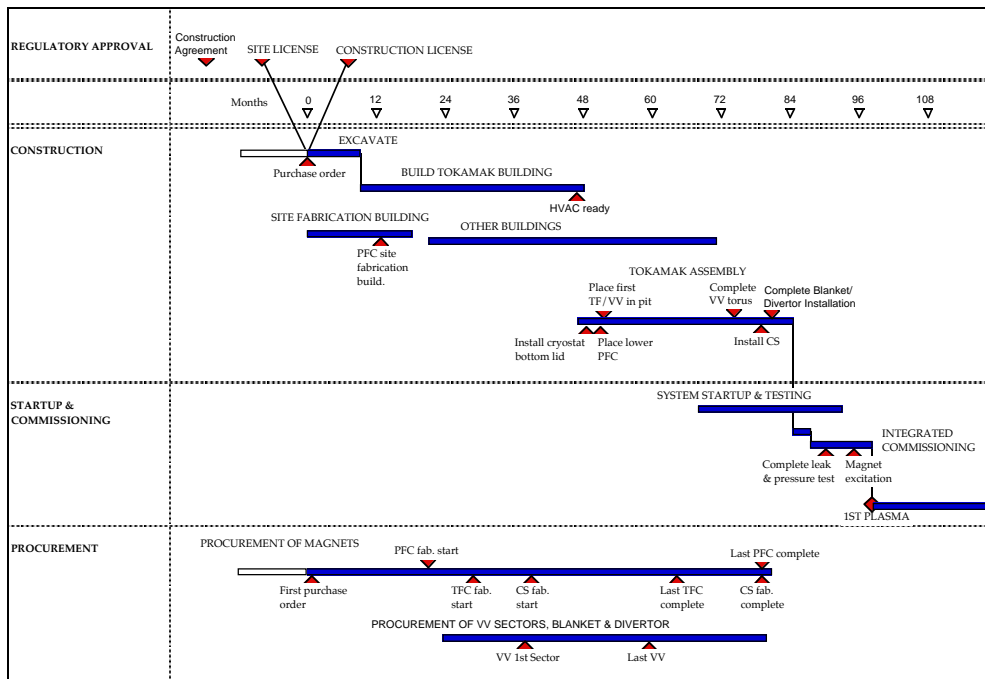

Operation Plans

Operation starts from the first plasma with hydrogen. The ITER machine will be fully commissioned and operated at full plasma current and the full heating power with H plasma discharges. At this time, operating with D plasma discharges with limited tritium, will allow all components and processes to be commissioned ready to work with tritium and with neutron irradiation, before the full deuterium-tritium operation starts to develop high-Q inductive, non-inductive and highly reliable operations suitable for blanket testing.

Hydrogen Phase (H-Phase)

In this first phase of operation (H-phase), no fusion reactions occur, and ITER in-vessel components are not activated and are not contaminated by tritium. ITER will be commissioned with tokamak discharges with the same electromagnetic characteristics as during active operation. By the end of this phase, the nominal plasma current will have been achieved at the maximum toroidal magnetic field and about 70 MW of external heating power with a flat-top duration of about one hundred seconds. The plasma scenario and its control in normal and off-normal conditions will have been established. The heat flux on the limiter and the peak heat flux on the divertor target will be in the same range of average values as for the reference operation for the DT-phase. Depending on plasma confinement characteristics with hydrogen (achievement of good H-mode at large enough densities), many features of the future operation of DT can be explored. Therefore the duration of this period may be lengthened if optimistic results are achieved.

Fig 8.2 Schedule for the first ten years of ITER-FEAT operation

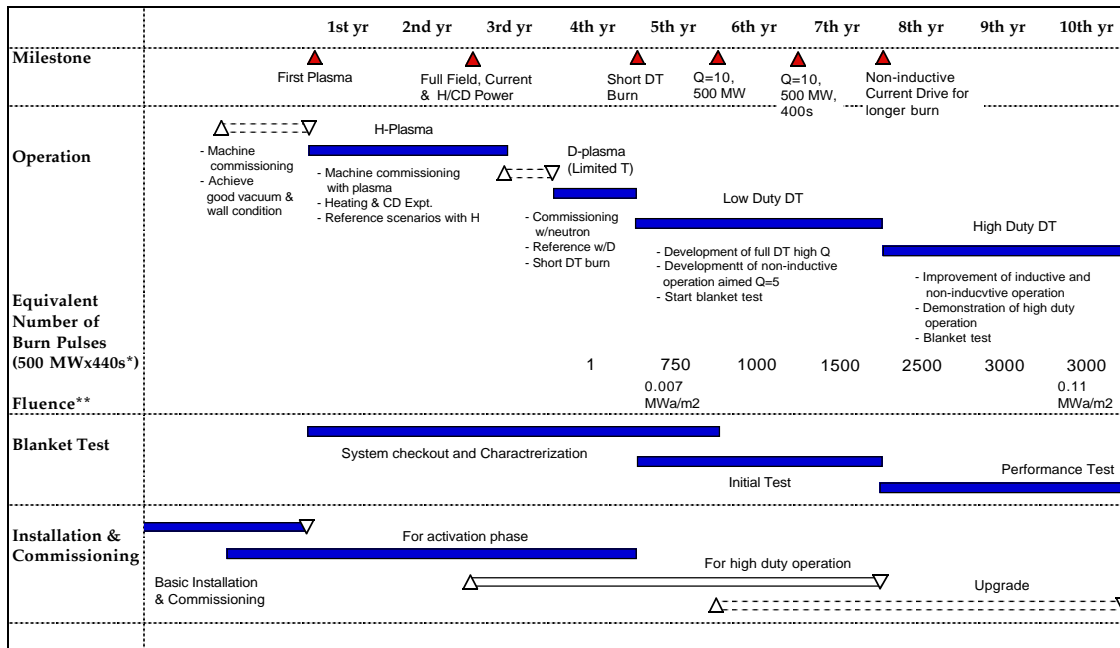

* The burn time of 400 sec includes 400 sec flat top and equivalent time which additional flux is counted during ramp-up and ramp-down.
 ** Fluence at outboard midplane (Neutron wall load is 0.57 MW/m² in average, 0.65MW/m² at outboard and 0.41 MW/m² at in board.)

Deuterium Phase with Limited Tritium Use (D-Phase)

The main purpose of this phase is to assess the mass scalings of performance, by comparison with H operation, and more accurately predict performance with DT, taking any necessary steps to correct or improve plasma control in preparation for full DT operation. By using limited amounts of tritium in a deuterium plasma, the integrated ITER system can be commissioned, especially with regard to shielding performance, including:

- "nuclear commissioning" of the machine with D/(T) plasma, including check and calibration of nuclear diagnostics, shielding test and radiation monitoring;
- research confirming operation with D/(T) plasma, albeit for short pulses;

Characteristics of D plasma behaviour are expected to be very similar to that of DT even if the alpha heating power is much less than the external heating power. Therefore, the reference plasma operational scenario including L-mode to H-mode transition, very short burn, demonstration of ELMy H-mode for a long period and plasma termination may be confirmed in this phase. The tritium balance can also be studied, and no vacuum vent is planned.

Deuterium-tritium plasma phases (DT-Phases)

Initially, physics studies will be done gradually by increasing and optimising the plasma operation space especially by developing reference scenarios for inductive and non-inductive operations. After developing reliable operation scenarios, series of pulses repeated continuously for a few days are planned mainly for engineering tests particularly relevant to breeding blanket test modules. The fluence at the end of this ~ 6 year phase will be typically ~ 0.1 MWam⁻².

A detailed operational plan for a second DT phase beyond the first ten years of operation has not been developed because it will depend on the plasma performance and operating experience obtained thus far. However, it is foreseen that there will be more emphasis on optimization of performances and reliable operation to produce higher neutron fluxes and fluence, using the most promising operational modes developed in the previous phases. The average neutron fluence on the first wall is planned to reach at least 0.3 MWam^{-2} at the end of the 20-year operation program.

Tritium Supply

During the first ten years of ITER operation, the equivalent total burn duration at 500 MW is planned to be about 0.15 years or the total equivalent number of pulses is 11,800 at 500 MW. The net consumption of tritium with 500 MW and 400 s burn is about 0.4 g. including heating-up and cool-down phases, and the total consumption during the first ten years are about 5 kg. To achieve the reference average neutron fluence on the first wall of 0.3 MWA/m^2 , a total net burn duration of 0.53 years at 500 MW of fusion power is needed, and about an additional 10 kg will be consumed. This tritium can be supplied by external sources.

Tritium Breeding Blanket Test Programme

ITER should "test tritium breeding blanket concepts that would lead in a future fusion reactor to tritium self-sufficiency, the extraction of high-grade heat, and electricity generation." To achieve this testing the ITER Parties will provide specific modules of their own design to be introduced in a few ITER equatorial ports. A common test blanket programme will be established. with the following main objectives:

- 1) to demonstrate tritium breeding performance and verify on-line tritium recovery and control systems;
- 2) to demonstrate high-grade heat extraction suitable for electricity generation;
- 3) to validate and calibrate the design tools and the database used in the blanket design process including neutronics, electromagnetic, heat transfer, and hydraulics;
- 4) to demonstrate the integral performance of blanket systems under different loading conditions;
- 5) to observe possible irradiation effects on the performance of the blanket modules.

Decommissioning Plan

It is assumed that the ITER organisation at the end of operation will be responsible for starting the machine decommissioning through a deactivation period after which the facility will be handed over to an organisation inside the ITER Host Country. The decommissioning plan is based on a logic of resources and equipment usage optimisation and takes into account the statutory Occupational Radiological Exposure (ORE) limits. The plan provides a framework within which the organisation that takes over responsibility for decommissioning can decide when and how to implement the ITER facility dismantling, depending on the financial, schedule, resources and/or any other priorities applicable at the time. Flexibility is provided by the use of two separate phases. Each phase duration and activity can be modified (to a certain extent) to accommodate the organisation requirements and constraints.

During the first phase, the machine will, immediately after shutdown, be de-activated and cleaned by removing tritium from the in-vessel components and any removable dust. Also, any liquid used in the ITER machine systems will be removed (assuming that no components cooling will be further required) and processed to remove the activation products prior to

their disposal. De-activation will include the removal and safe disposal of all the in-vessel components and, possibly, the ex-vessel components. ITER de-activation will also provide corrosion protection for components, which are vulnerable to corrosion during the storage and dismantling period, if such corrosion would lead to spread of contamination or present unacceptable hazards to the public or workers. These activities, part of phase 1 of the decommissioning schedule, will be carried out by the ITER organization using the remote handling facilities and staff existing at the end of the project. At the end of phase 1, the ITER facility will be handed over to the organization inside the Host Country that will be responsible for the subsequent phase of decommissioning, after a dormant period of some decades for radioactive decay after which final dismantling and disposal could proceed.

Conclusions

1 The ITER-FEAT outline design meets the requirements set at the ITER Meeting in Cadarache, March 1999. It facilitates the exploration of a domain of inductive operation around $Q \geq 10$, in which isotropic α -particles are the dominant source of plasma heating and the main determinant of plasma behaviour. It could be used, with appropriate enhancements to the heating and current drive systems, to approach steady-state operation with $Q \geq 5$.

2 The design point for ITER-FEAT results from systems analysis and intensive joint assessments by Task Forces involving all the Parties. It represents an agreed appropriate compromise among the many interacting scientific, technical and cost constraints and objectives, recognising the importance of providing robustness to the unavoidable uncertainties of the plasma performance projections and of the need to offer capacity to exploit new physics results and understandings. The performance projections are based on a conservative choice of scaling extrapolation. Tools have been identified to allow the boundaries of the operating domain to be expanded and to mitigate possible problems should actual performance prove to lie in the adverse regions of the uncertainty ranges.

3 The parameter set and size appear to be sound even though the margins against uncertainty of the confinement extrapolation are not so large as first envisaged. It would be imprudent to compress or constrain the design further in the hope of achieving further cost savings.

4 Thus, in meeting the ITER mission to demonstrate the scientific feasibility of fusion energy, the conditions of plasma operation in ITER-FEAT will make technological demands that necessarily integrate and demonstrate key technologies for fusion energy - notably superconducting magnet coils, fusion fuel cycle operation, accommodation of heat flux and neutron flux and fluences and the application of remote handling and maintenance technologies. ITER-FEAT will have the capacity to test principles and concepts for other fusion technologies such as breeding blanket modules.

5 The engineering features of the design rest on the approaches and solutions developed and qualified for the 1998 ITER design. The continuing flow of results from the large technology R&D projects provide a basis for confidence in the feasibility, performance and operating margins for the various systems.

6 The initial cost scoping exercise, based mainly on simple scaling from the industrial cost studies of the 1998 ITER Final Design Report, indicates a total capital cost estimated at about 56% that of the 1998 design and provides mainly the relative cost of the different systems as a percentage of the total. Indicative estimates of operating costs are about 51% those estimated for the 1998 design. A proper cost estimate of ITER-FEAT will be obtainable only after a new round of industrial estimates of procurement packages based on detailed design of components and systems. Such studies will be able to quantify the opportunities for re-optimising the manufacturing around the new design and for taking full benefit of the results emerging from the large technology R&D programmes. Thus, there appears to be scope for further reductions in total capital cost.

7 Analysis to date indicates that the favourable overall assessment of the safety and environmental characteristics of the 1998 ITER design applies also to the ITER-FEAT outline design; the analysis is being further refined around the specifics of the design and planned operations. The safety principles and criteria for ITER safety are being further developed with the aim of developing a consensus among the Parties in this area with their regulatory authorities before the case will be presented to the Host Authority.

8 Subject to the views of the ITER Council and of the Parties on the content of the present report and its supporting technical information, the project is in a position now to proceed to detailed design of the ITER-FEAT systems, to resolve the remaining open design issues, to prepare the inputs for industrial cost estimates, and to extend the safety and environmental assessments with the view to providing by the end of the ITER EDA extension, a sufficient technical basis for a possible decision by the Parties to proceed to joint construction and operation of ITER-FEAT.