



Status of Z-Pinch for IFE

Z-IFE Recent Results

long-term goals: Power production, Hydrogen production

nearer-term goals: GNEP, Nuclear waste transmutation



RTL

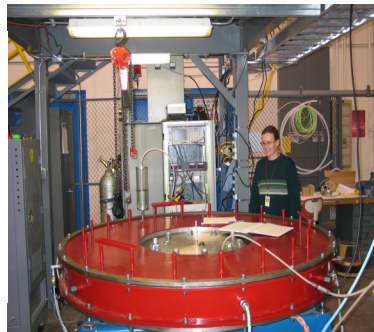

LTD driver



Shock Mitigation

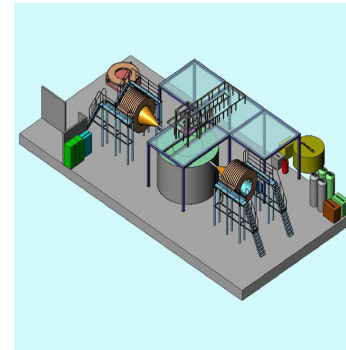

Z-PoP

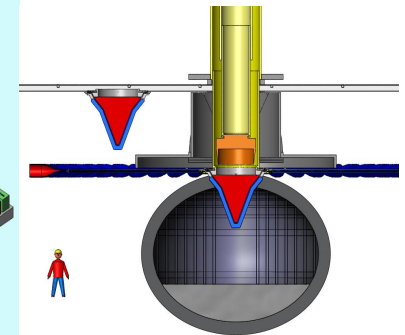

Chamber

Craig L. Olson + Z-IFE Team
Sandia National Laboratories
Albuquerque, NM 87185

Fusion Power Associates
Annual Meeting and Symposium
Washington, DC
September 27-28, 2006



Sandia is a multiprogram laboratory operated by Sandia Corporation, a Lockheed Martin Company, for the United States Department of Energy's National Nuclear Security Administration under contract DE-AC04-94AL85000.



The Z-Pinch IFE Team

C. Olson, G. Rochau, M. Mazarakis, S. Slutz, R. Olson, M. Cuneo, T. Sanford, W. Stygar, R. Vesey, T. Mehlhorn, K. Struve, W. Fowler, R. Sharpe, S. Rogowski, A. Owen, T. Pointon, M. Kiefer, S. Rosenthal, R. McKee, J. Jones, F. Long, L. Shippers, J. McDonald, P. Wakeland, C. Walker, G. Benevides, E. Weinbrecht, W. Krych, C. Morrow, C. Farnum, M. Modesto, D. Oscar, L. Chhabildas, W. Reinhart, V. Vigil, R. Keith, M. Turgeon, B. Smith, B. Cipiti, S. Rodriguez, E. Lindgren, J. Cook, S. Durbin, A. Guild, J. Oakley, L. Perez, O. Rivera, D. Smith, K. Peterson, V. Dandini, D. McDaniel, M. K. Matzen, R. Stulen, J. P. VanDevender, L. Shephard, M. Walck, T. Renk, T. Tanaka, M. Ulrickson, P. Peterson, C. Debonnel, J. De Groot, R. Peterson, G. Pollock, J. Grondalski, P. Ottinger, J. Schumer, D. Kammer, I. Golovkin, G. Kulcinski, L. El-Guebaly, G. Moses, E. Mogahed, I. Sviatoslavsky, M. Sawan, M. Anderson, R. Bonazza, R. Gallix, C. Charman, N. Alexander, W. Rickman, H. Tran, W. Meier, J. Latkowski, R. Moir, R. Schmitt, R. Abbot, S. Reyes, M. Abdou, A. Ying, P. Calderoni, L. Schmitz, N. Morley, S. Abdel-Khalik, M. Barkey, D. Welch, D. Rose, W. Szaroletta, K. McDonald, D. Louie, S. Dean, A. Kim, S. Nedoseev, E. Grabovsky, A. Kingsep, V. Smirnov

Lead National Laboratory

SNL

Collaborating National Laboratories:

LLNL, NRL, LANL

Collaborating Universities:

U. Wisconsin, UCB, UCD, UCLA, Georgia-Tech., U. Alabama

Collaborating Industry:

GA, Voss, SAIC

Collaborating Institutions in Russia:

Kurchatov Institute (Moscow)

Institute for High Current Electronics (Tomsk)



Recyclable Transmission Line (RTL) Concept for Z-Pinch IFE

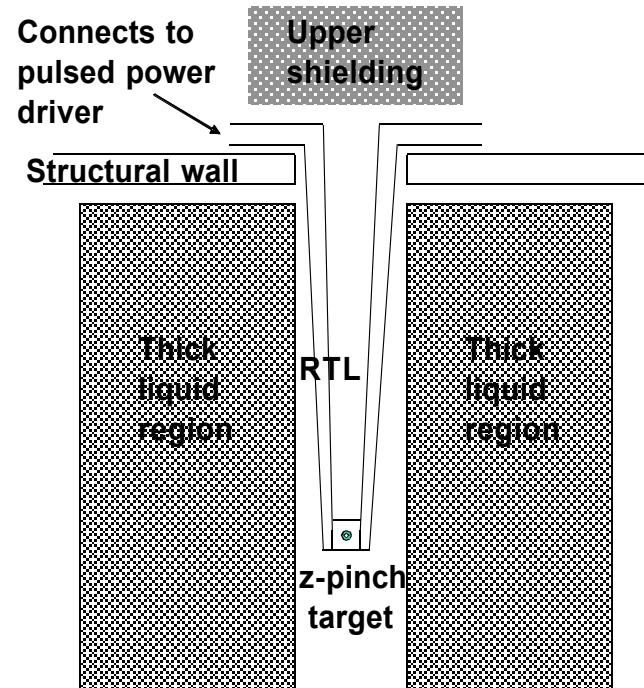

Yield and Rep-Rate: few GJ every 3-10 seconds per chamber (0.1 Hz - 0.3 Hz)
Thick liquid wall chamber: only one opening (at top) for driver; nominal pressure (10-20 Torr)
RTL entrance hole is only 1% of the chamber surface area (for $R = 5$ m, $r = 1$ m)
Flibe absorbs neutron energy, breeds tritium, shields structural wall from neutrons
Neutronics studies indicate 40 year wall lifetimes
Activation studies indicate 1-1.5 days cool-down time for RTLs
Studies of waste steam analysis, RTL manufacturing, heat cycle, etc. in progress

- Eliminates problems of final optic, pointing and tracking N beams, and high-speed target injection
- Requires development of RTL



Z-Pinch IFE Power Plant has a Matrix of Possibilities

Repetitive Z-Pinch Driver:

Marx generator/
water line technology

magnetic switching
(RHEPP technology)

linear transformer driver
(LTD technology)

RTL (Recyclable Transmission Line):

frozen coolant
(e.g., Flibe/ electrical coating)

immiscible material
(e. g., carbon steel)

Target:

double-pinch

dynamic hohlraum

fast ignition

Chamber:

dry-wall

wetted-wall

thick-liquid wall

solid/voids
(e. g., Flibe foam)

**Thick liquid walls essentially alleviate the “first wall” problem.
No new neutron test facilities are required.**



Recent Results in Z-IFE

1. RTLs

simulations (> 5 MA/cm works)
experiments (> 5 MA/cm works)
fabrication of PoP-size RTLs
and pressure testing



2. LTD repetitive driver

0.5 MA, 100 kV LTD cavity
fires every 10 seconds
1.0 MA, 100 kV LTD cavities (5)
voltage-adder tests
full IFE driver architectures



3. Shock mitigation

theory
experiments: water ring/explosives
foamed liquids
shock tube/foams
simulations



4. Z-PoP planning

vacuum/electrical
connections
overhead automation
animations
costing

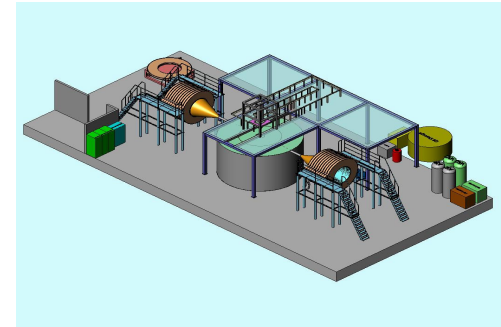

5. Z-IFE targets for 3 GJ yields

gains ~ 50-100
double-pinch/dynamic hohlraum
scaling studies

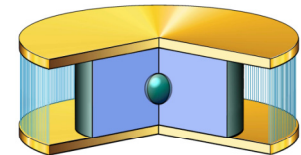

6. Z-IFE power Plant

RTL manufacturing/costing
wall activation studies:
40 year lifetime
power plant design
+GNEP, transmutation

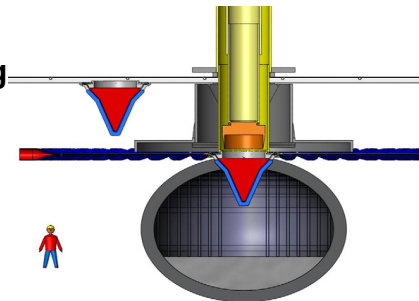

Sandia is a multiprogram laboratory operated by Sandia Corporation, a Lockheed Martin Company, for the United States Department of Energy's National Nuclear Security Administration under contract DE-AC04-94AL85000.





ALEGRA simulations of RTL with random imperfections still shows robust power flow

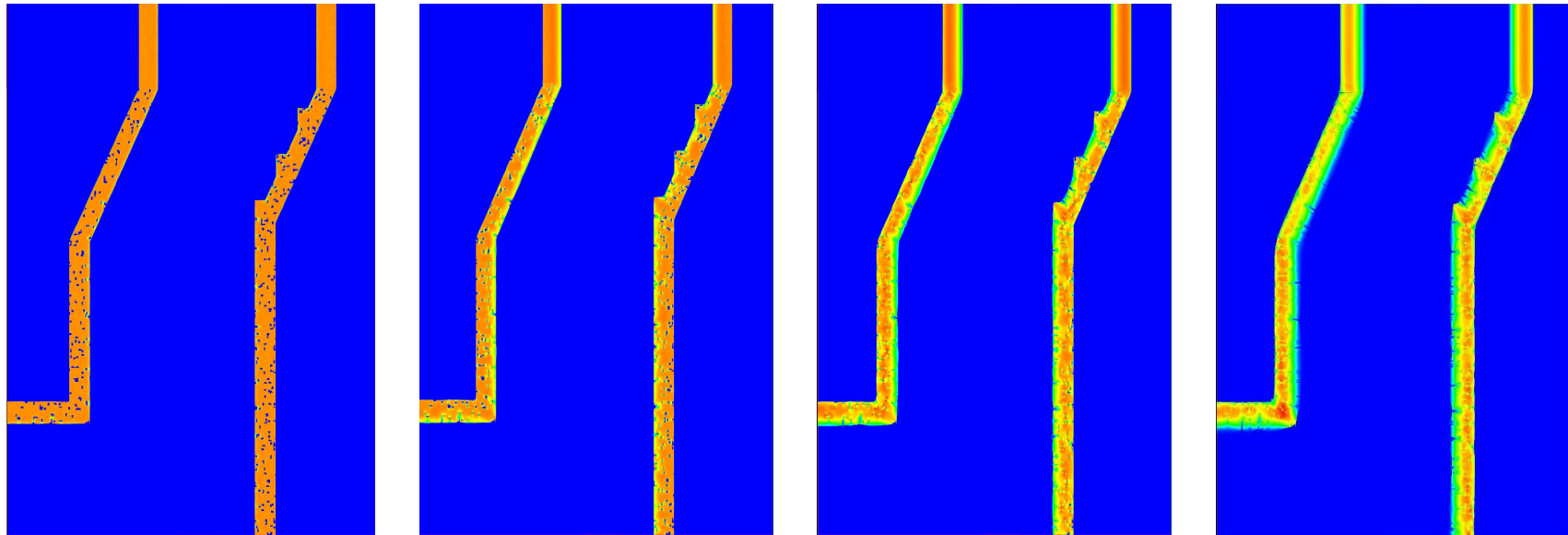

t = 15 ns

30 ns

45 ns

60 ns

AK gap: 2 mm

RTL wall thickness: 0.025 inches = 635 microns

Power pulse: rising to 60 MA in 100 ns

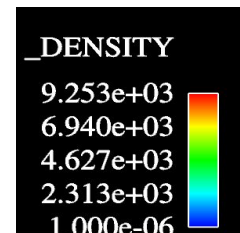

Sandia is a multiprogram laboratory operated by Sandia Corporation, a Lockheed Martin Company, for the United States Department of Energy's National Nuclear Security Administration under contract DE-AC04-94AL85000.



The physics of electron and ion flow in RTLs has been studied analytically and with LSP simulations:

AK gaps at the load should be ≥ 2 mm

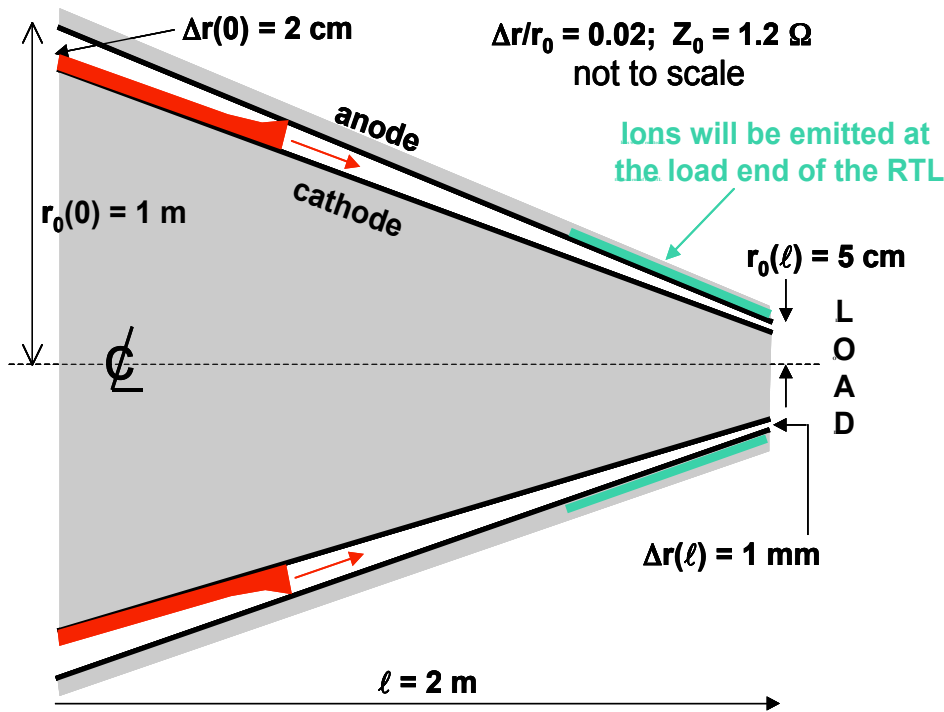

Conical tapered RTL for the baseline Z-IFE design. Power is fed in from the left.

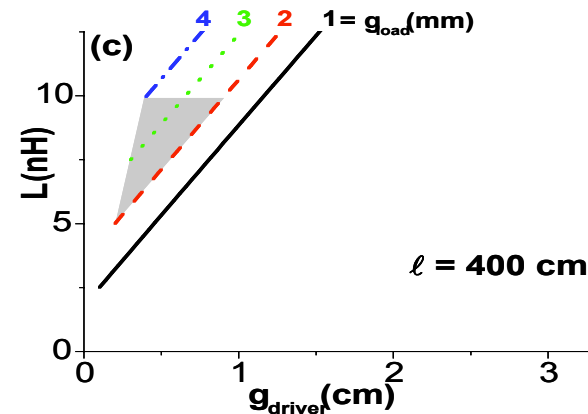
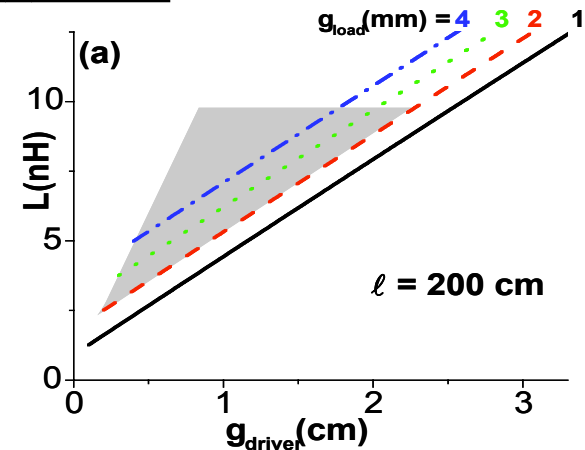

RTL inductance as a function of AK gap at the input end for various values of AK gap at the load. Shaded area are allowed design areas.

RTL buckling mode analysis leads to optimized RTL shape, that permits lower mass RTLs

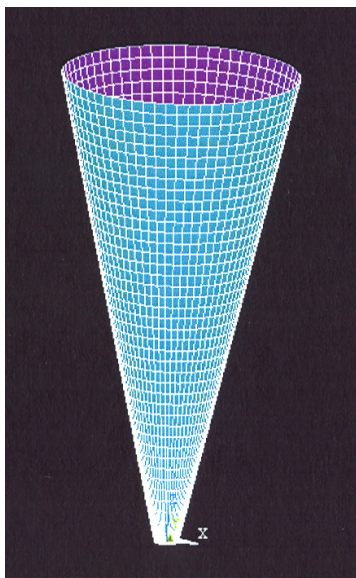

Single segment RTL

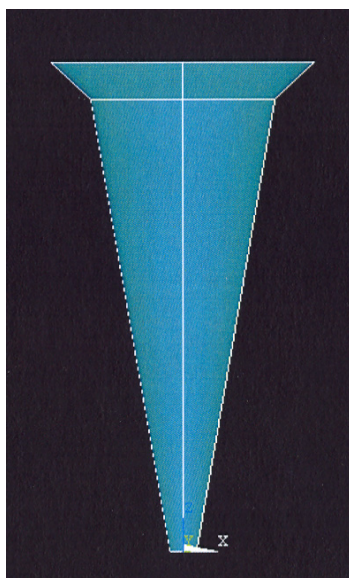

Two-segment RTL

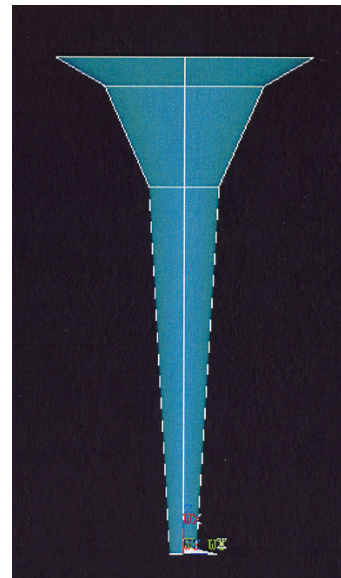

Three-segment RTL

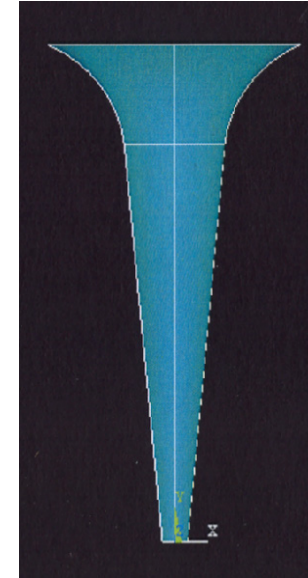

Curved RTL

<u>RTL design</u>	<u>Eigenbuckling Pressure (dyne/cm³)</u>	<u>Enhancement over single-segment</u>
single-segment	249,755	1.0
two-segment	490,117	1.96
three-segment	730,507	2.92
curved	748,966	3.00

(22) PoP-RTLs were constructed and pressure tested to buckling with various stiffening rings



PoP-RTL cone made by Toledo Metal Spinning



Stiffening rings mounted to PoP- RTL cone

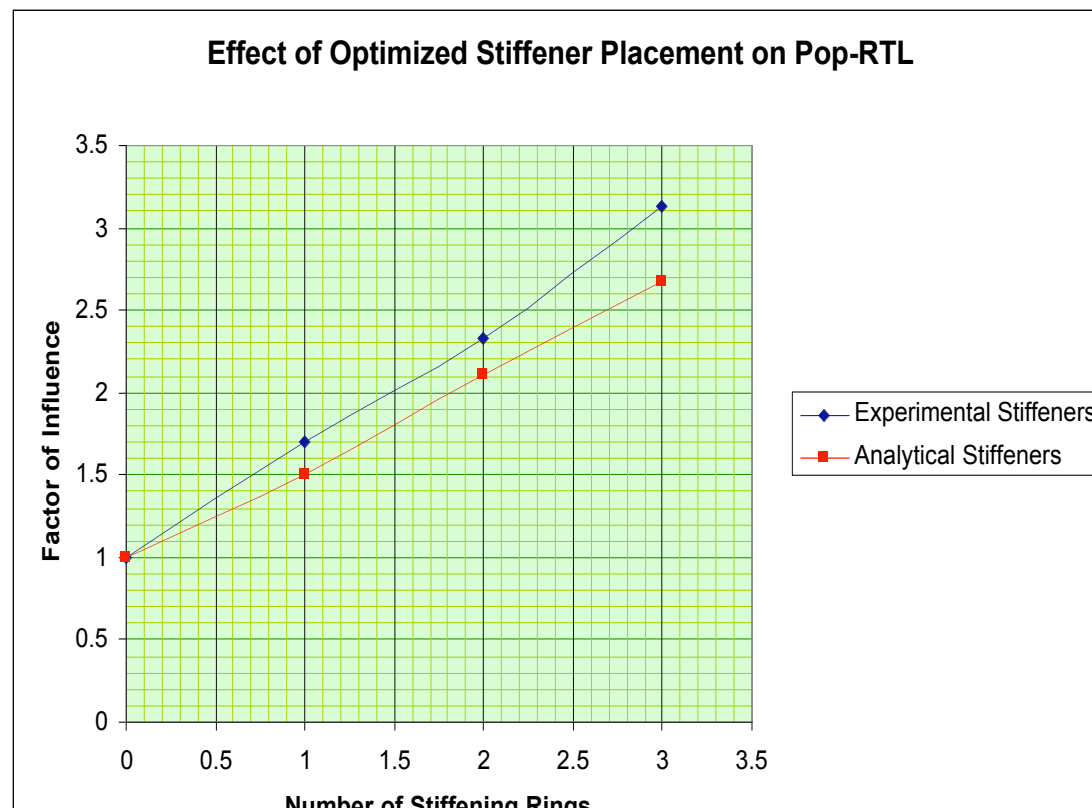

Stiffeners significantly increase the structural performance of the PoP-RTL without adding significant mass

Repetitive, 0.5 MA, 100-kV LTD Cavity is in operation at SNL

SNL high current LTD Laboratory

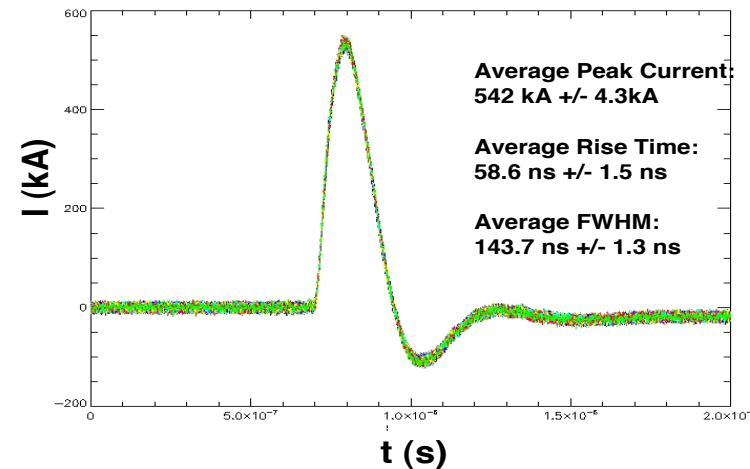

Overlay of 100 shots at 0.03 Hz
for 90 kV charging

40 Maxwell 31165 caps,
20 switches, ± 100 kV
0.2 Ohm load 0.05TW

At SNL: This 0.5 MA cavity has been fired in repetitive mode for
 ~ 3000 shots; the last set of 50 shots with one shot every
10.25 seconds (~ 0.1 Hz)

At Tomsk: One switch has been fired 37,000 shots
with one shot every 12 seconds (~ 0.08 Hz)

Five 1.0 MA LTD cavities have been built in Tomsk, Russia
(this is the building block for Z-PoP and future Z-IFE drivers)

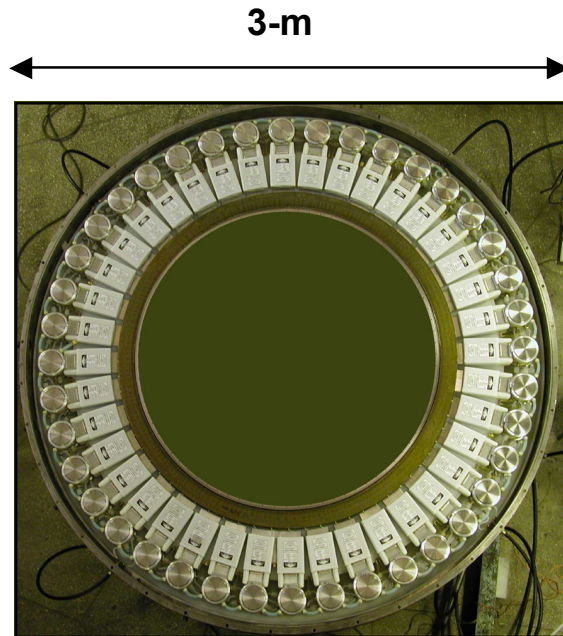

1-MA, 100kV, 70ns LTD cavity
(top flange removed)

80 Maxwell 31165 caps,
40 switches, ± 100 kV

0.1 Ohm load **0.1TW**

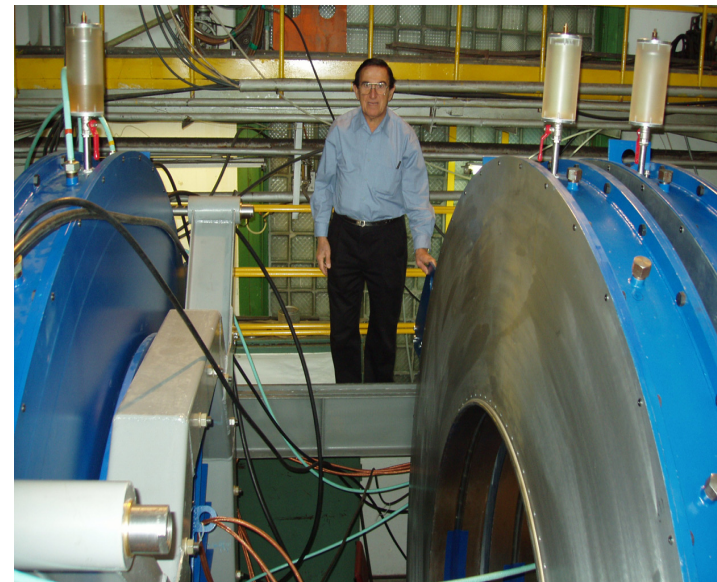

Test stand for Voltage adder testing of
five 1.0 MA LTD cavities (High Current
Electronics Institute – Tomsk, Russia)

September 2006

An IFE driver (60 MA), with seventy 1-MA voltage-adder modules, each with 70 LTD cavities (SNL)

104 m diameter

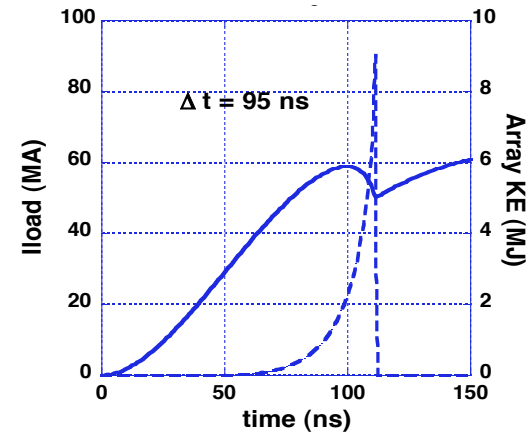
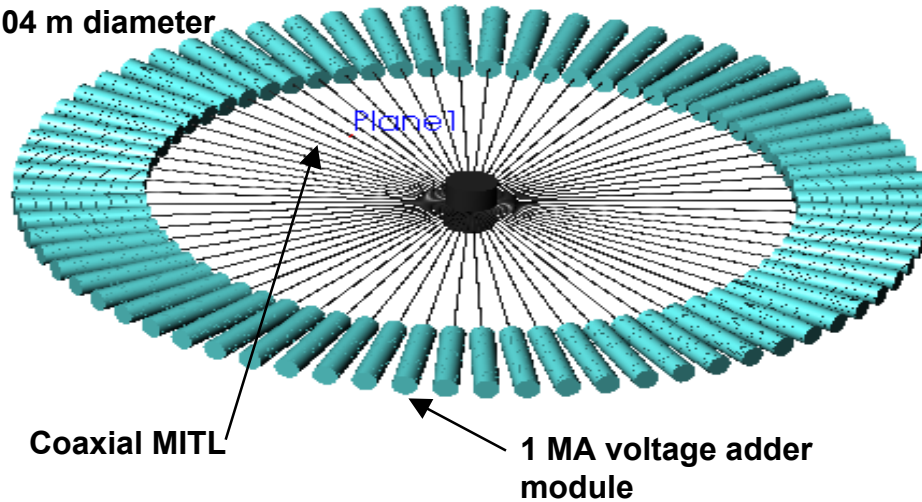

55 mg array load

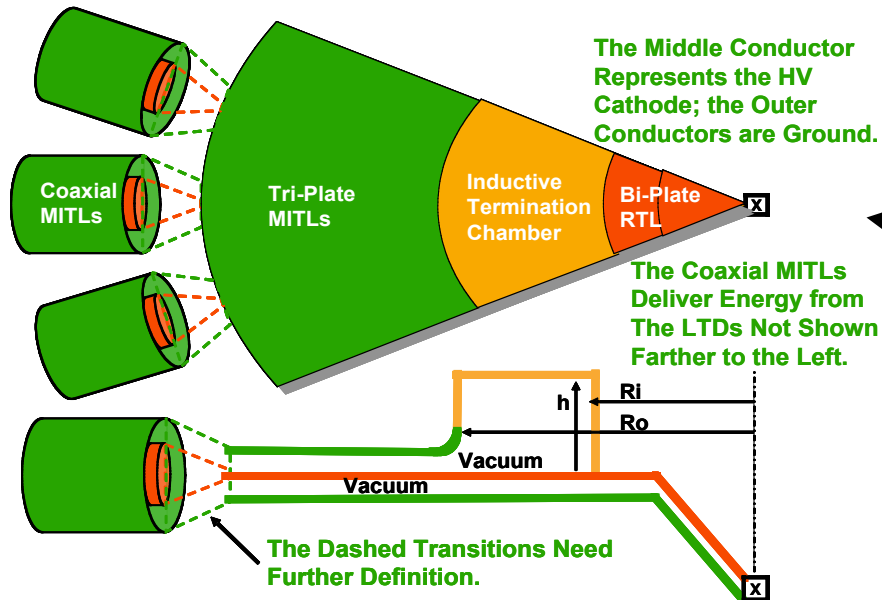

Top pie-section and side views of the Coaxial to Tri-Plate to Bi-Plate transition geometry

An IFE driver (90 MA) with 120 LTD modules
(Kurchatov – Moscow, Russia)

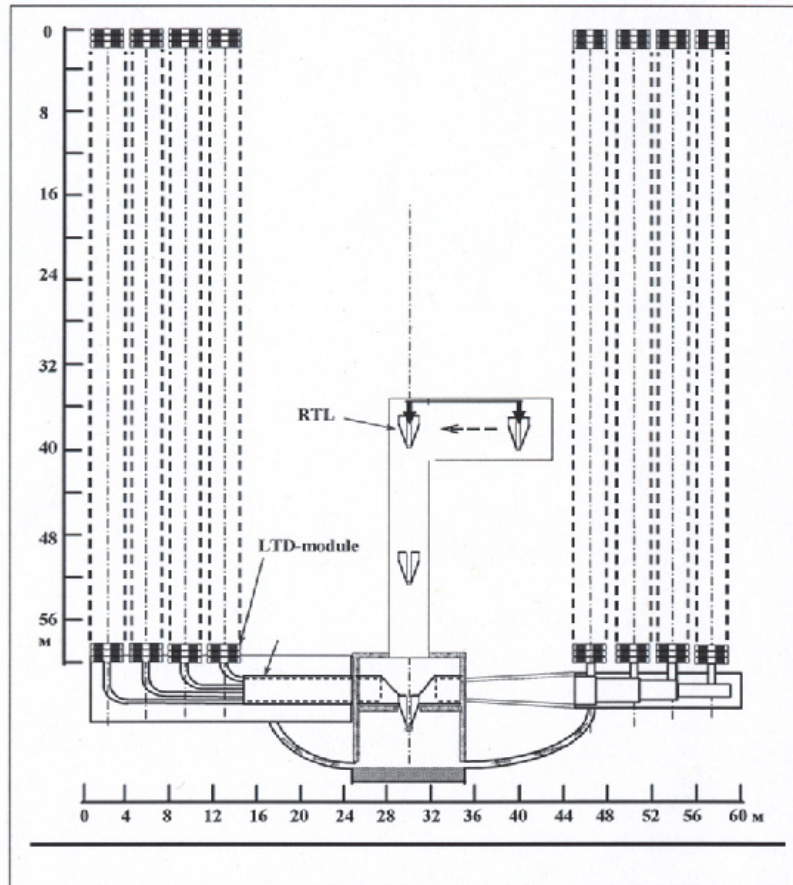

General conceptual scheme of LTD generator and reactor chamber for ZP-3R

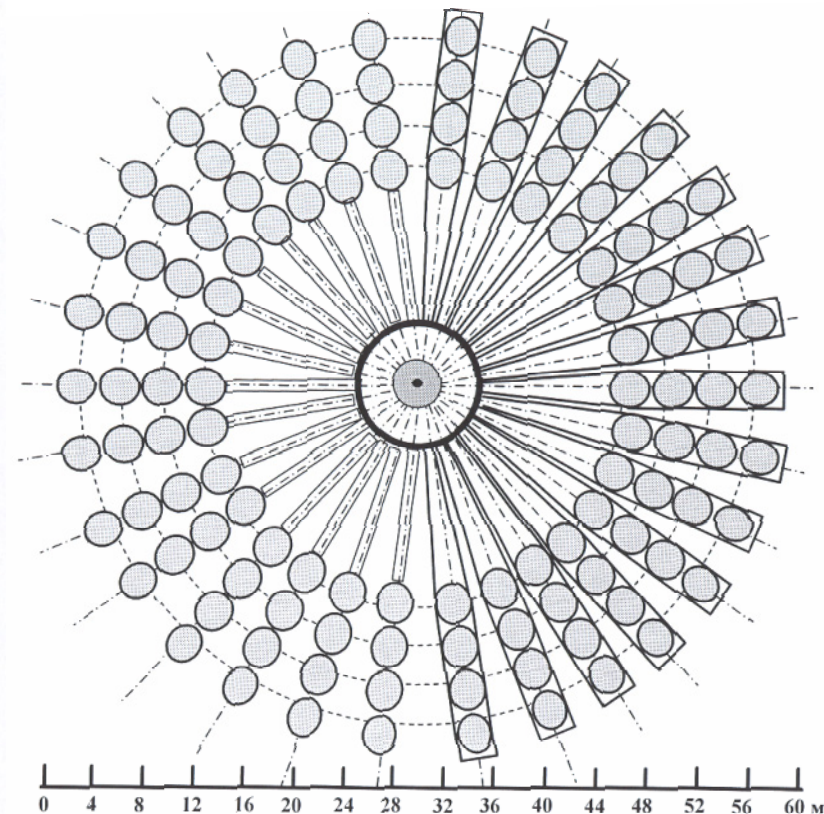

Top view of LTD modules of ZP-3R

Annular water jets with an exploding wire on axis are used to study shock mitigation for thick liquid walls

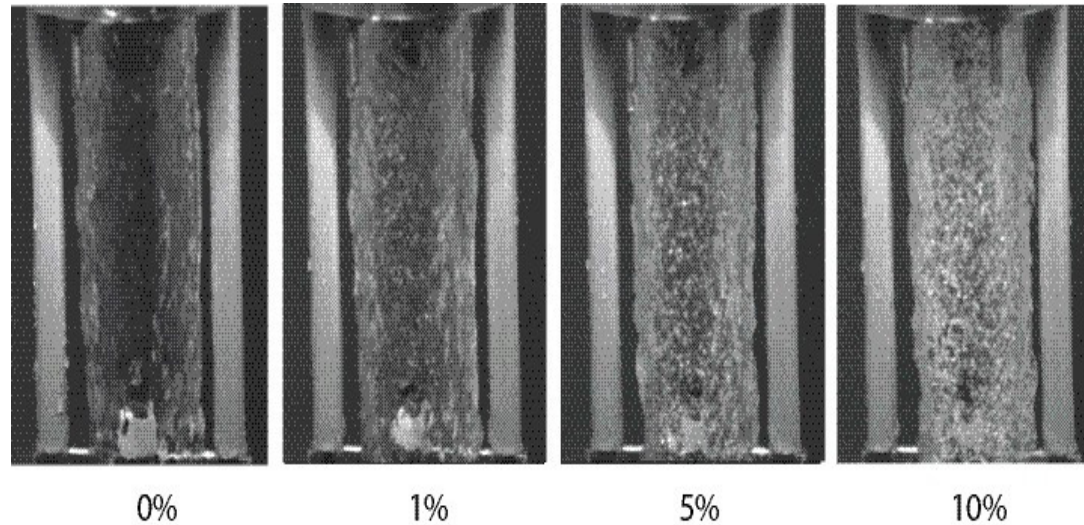

Photographs showing near-field behavior of two-phase annular jets with different void fractions (liquid superficial velocity $v = 2$ m/s)

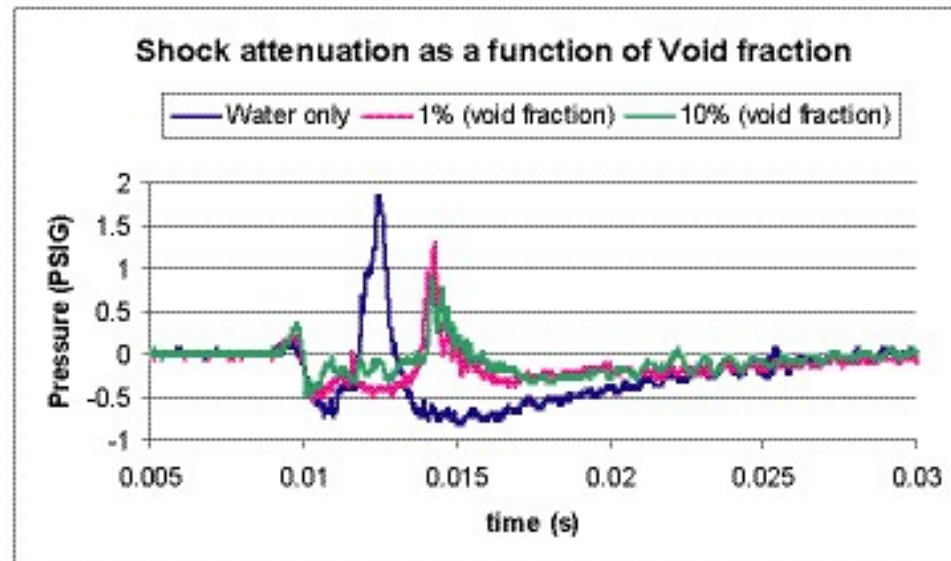

Annular water jet + high explosives used to investigate shock mitigation for thick liquid walls (VHEX facility)

a) EBW

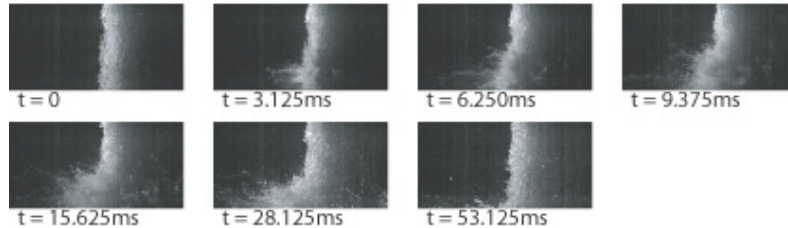

Exploding bridge wire (EBW)

Peak pressure: 4.5 atmospheres

Impulse duration: 180 μ s

Raw integrated impulse: 22 Pa.s

b) EBW + 2.5 g of HE

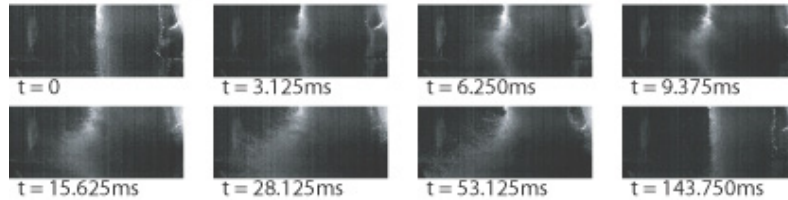

EBW + 2.5 g of HE (C4)

Peak pressure: 21 atmospheres

Impulse duration: 140 μ s

Raw integrated impulse: 55 Pa.s

c) EBW + 5.0 g of HE

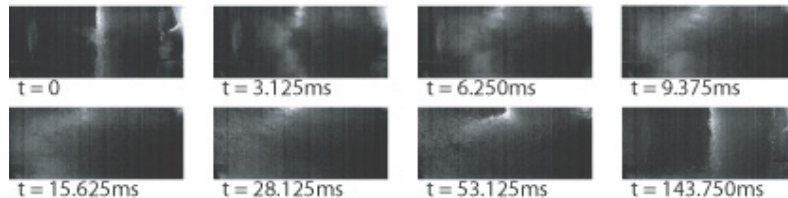

EBW + 5 g of HE (C4)

Peak pressure: 105 atmospheres

Impulse duration: 80 μ s

Raw integrated impulse: 100 Pa.s

d) EBW + 23 g of HE

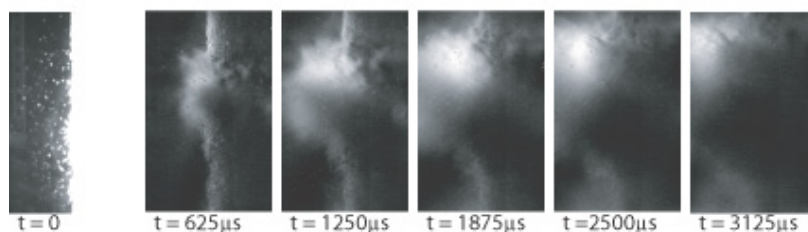

EBW + 23 g of HE (C4)

Crushing of porous liquid structures transfers momentum uniformly into the blanket mass without jetting or spall

Z – PoP (two 1 MA legs)

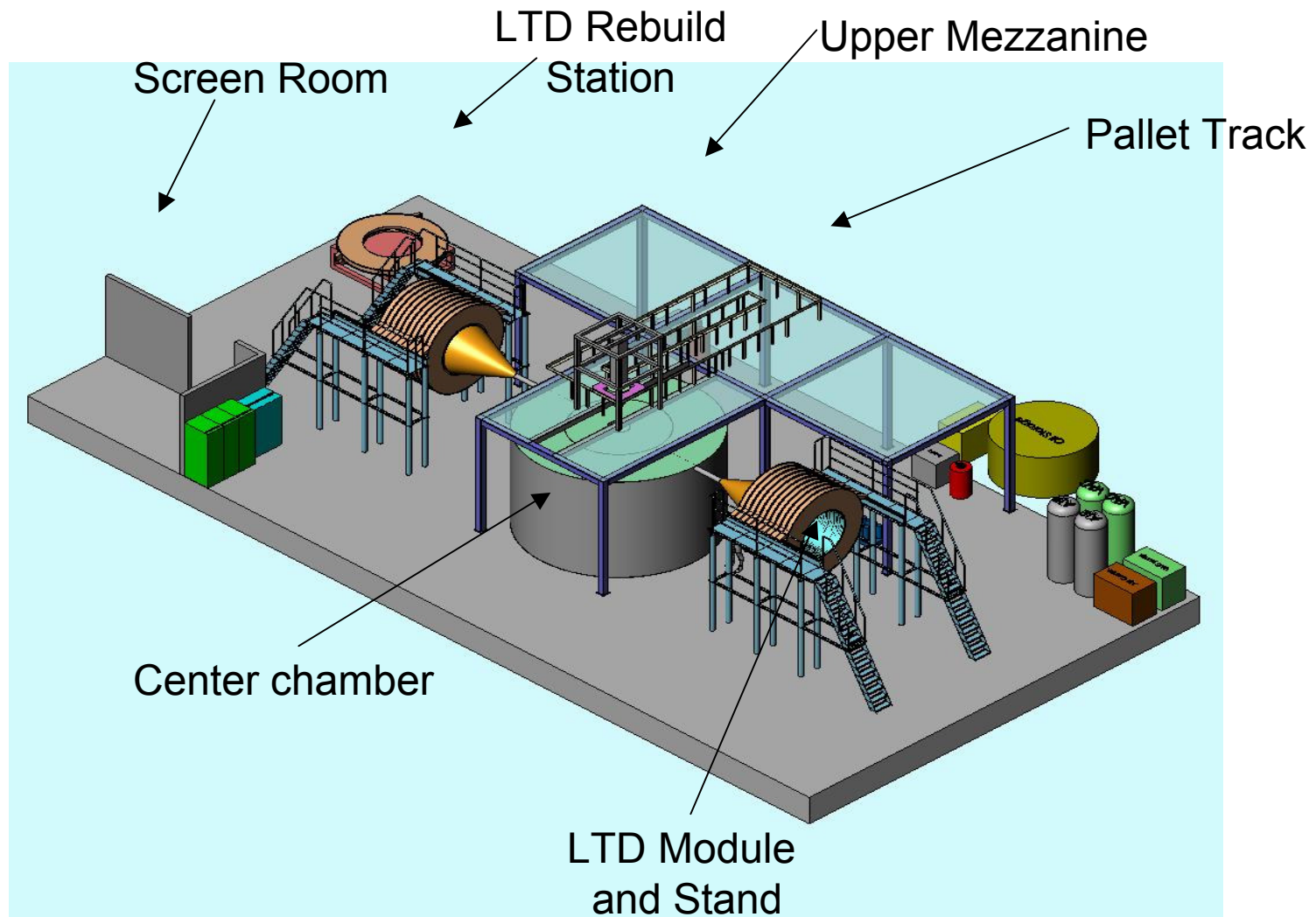

Cost Estimate: two lines in three years: \$15 M in FY05 \$

Z – PoP (ten 1 MA legs)

comparable to a rep-rated Saturn at 10 MA

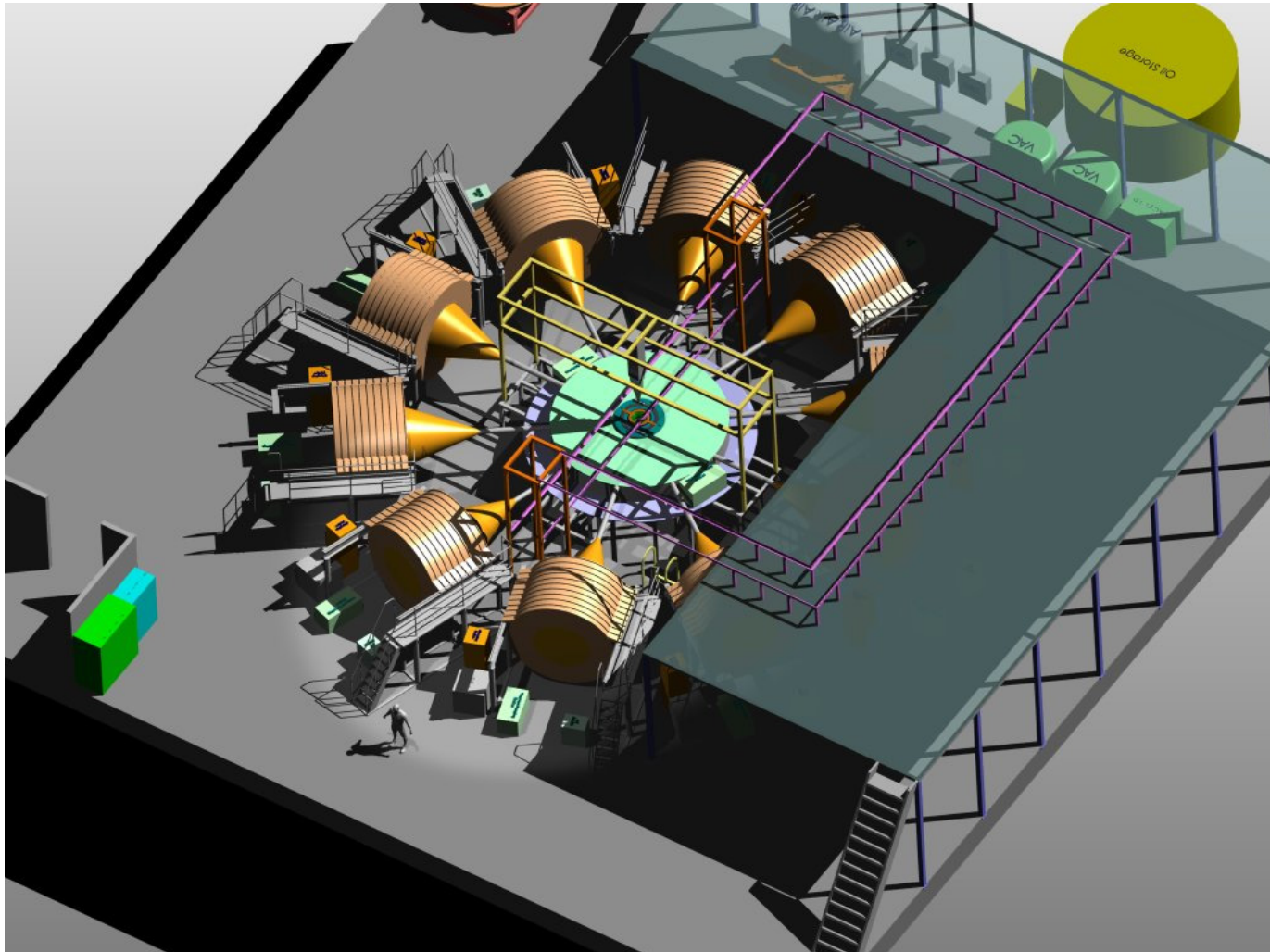

Cost Estimate: ten lines in five years: \$35.2 M in FY05 \$

Simulation results and scaling of Z-pinch indirect-drive target concepts for high-yield ICF and Z-IFE

Double-Ended Hohraum

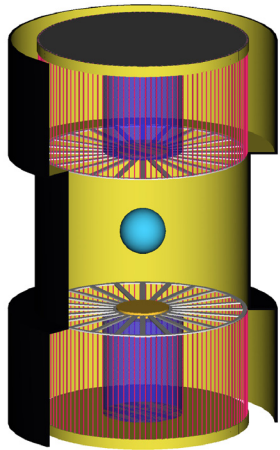

ICF _ IFE

Peak current	2 x (62 – 116) MA
Energy delivered to pinches	2 x (19 – 67) MJ
Z-pinch x-ray energy output	2 x (9 – 33) MJ
Capsule absorbed energy	1.2 – 8.6 MJ
Capsule yield	400 – 4500 MJ

Dynamic Hohraum

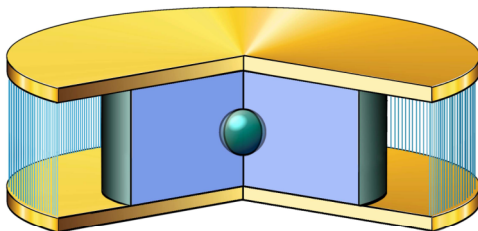

Peak current	56 – 95 MA
Energy delivered to pinch	14 – 42 MJ
Capsule absorbed energy	2.4 – 7.2 MJ
Capsule yield	530 – 4600 MJ

BASE Z-IFE UNIT

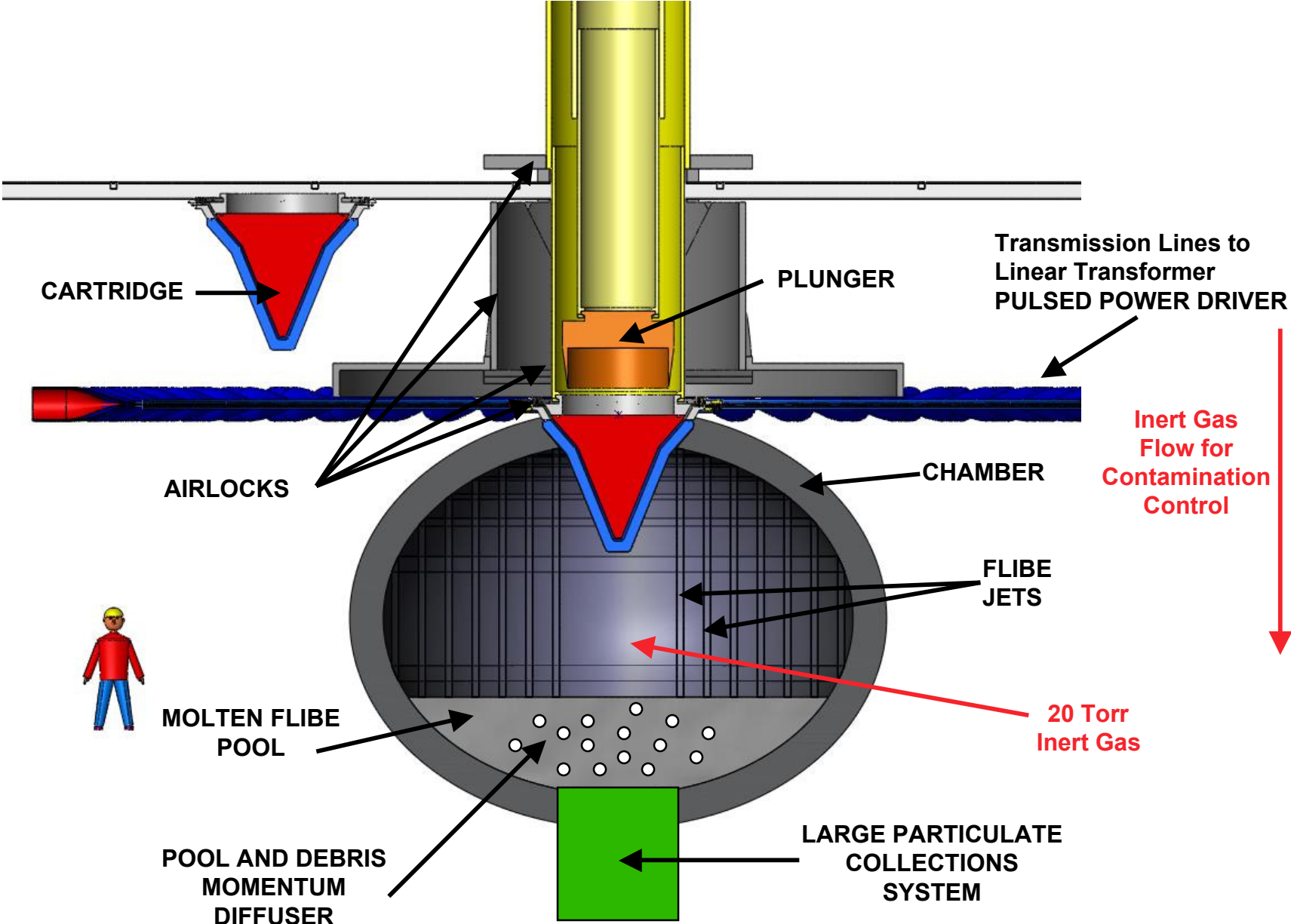

CARTRIDGE

PLUNGER

Transmission Lines to
Linear Transformer
PULSED POWER DRIVER

AIRLOCKS

CHAMBER

Inert Gas
Flow for
Contamination
Control

FLIBE
JETS



MOLTEN FLIBE
POOL

20 Torr
Inert Gas

POOL AND DEBRIS
MOMENTUM
DIFFUSER

LARGE PARTICULATE
COLLECTIONS
SYSTEM



In-Zinerator includes a sub-critical blanket to burn actinides – produces transmutation of waste and produces power

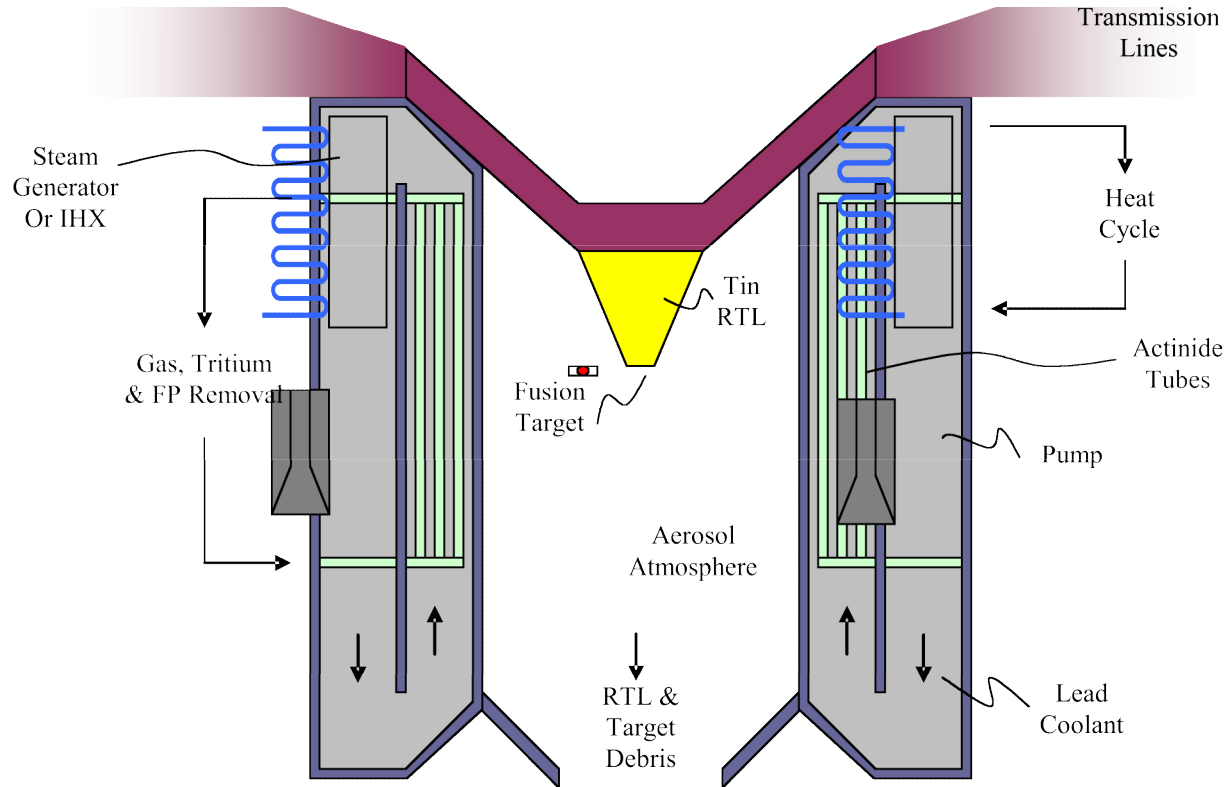

In-Zinerator Power Plant



Z-Pinch parameters for: Z-IFE Power Plant Transmutation Plant

<u>Parameter</u>	<u>Z-IFE Power Plant</u>	<u>In-Zinerator</u>
Fusion Target Yield	3,000 MJ	200 MJ
Repetition Rate	0.1 Hz	0.1 Hz
Power per Chamber	390 MWth	3,000 MWth
Transmutation Rate	N/A	1,200 kg/yr
k_{eff}	N/A	0.97
Energy Multiplication	N/A	150
Number of Chambers	10	1
<i>RTL & Target</i>		
RTL Material	1006 carbon steel	Tin ??
Cone Dimensions	1m Ø x 0.1m Ø x 2m H	1m Ø x 0.1m Ø x 1m H
Mass per RTL	34 kg	93 kg
<i>Chamber Design</i>		
Shape	Spherical	Cylindrical
Dimension	5.9 m outer radius	3.2 m outer radius
Chamber Material	F82H	F82H or Hasteloy-N
Wall Thickness	35 cm	5 cm
<i>Blanket</i>		
Actinide Mixture	N/A	(LiF) ₂ -AmF ₃
Coolant	Flibe	Lead
Coolant Configuration	Jet and Pool	Shell & Tube (contained)
First Wall Configuration	Thick liquid wall	Structural Wall
Shock Mitigation	Thick, voided coolant	Argon Aerosol
Coolant Operating Temperature	950 K	950 K
Heat Cycle	Rankine	Rankine

Overall System for Hydrogen Production using Z-Pinch IFE

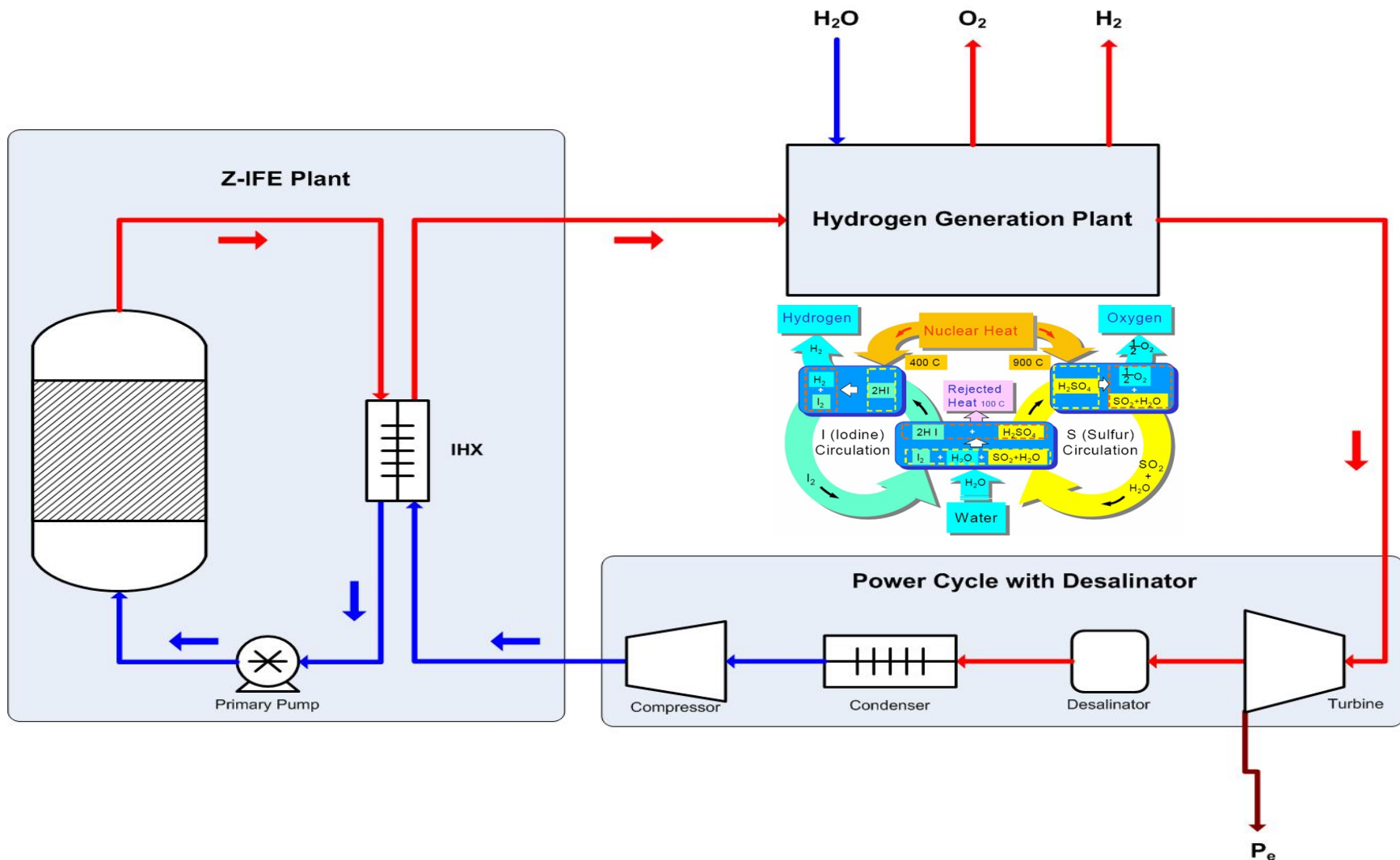



Hydrogen Production Costs for Various Methods

<u>Production method (Ref. 1)</u>	<u>Cost (\$/kg)</u>
Coal gasification	0.68
Non-catalytic partial oxidation	1.69
Thermo-chemical nuclear (fission) (Ref.2)	1.38
Thermo-chemical nuclear (fusion) z-pinch driven	1.62-2.23
Steam methane reformation	1.12-1.76
Electrolysis (depends on cost of electricity)	1.98-5.64

- Ref. 1. T.E. Drennen, et al., "The Hydrogen Futures Simulation Model (H2Sim) Technical Description," Sandia Report SAND2004-4937 (2005).
- Ref. 2. K.R. Schultz, et al., "Large-Scale Production of Hydrogen by Nuclear Energy for the Hydrogen Economy," National Hydrogen Assoc. Annual Conference, Washington, DC, March 5, 2003.

Unique features of z-pinch driven fusion hydrogen production:

- essentially unlimited source of energy**
- no greenhouse gases**
- no long-lived radioactive waste**



Z-IFE Funding

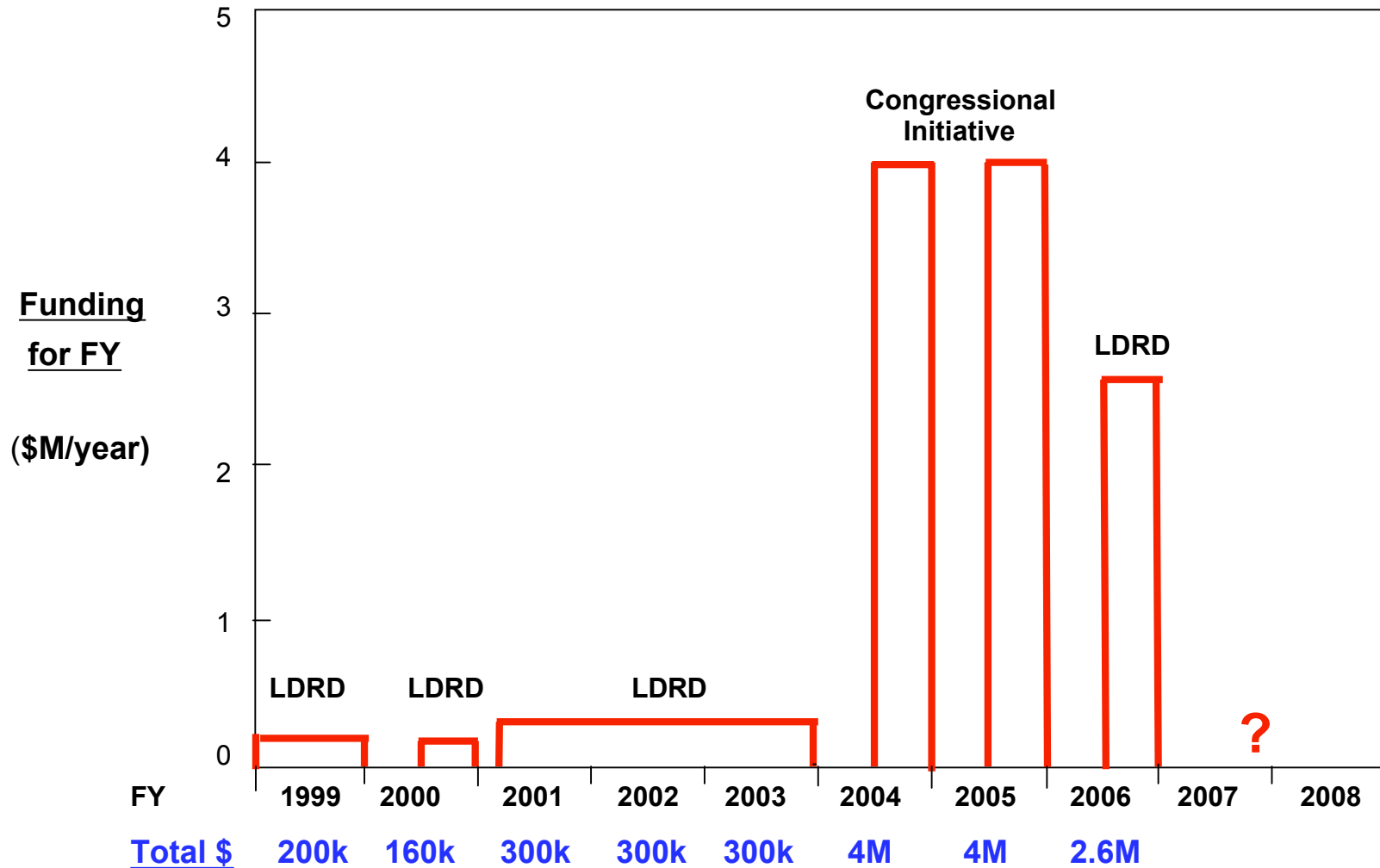

Sandia is a multiprogram laboratory operated by Sandia Corporation, a Lockheed Martin Company, for the United States Department of Energy's National Nuclear Security Administration under contract DE-AC04-94AL85000.





Status of Z-Pinch for IFE

Z-IFE Recent Results

long-term goals: Power production, Hydrogen production

nearer-term goals: GNEP, Nuclear waste transmutation



RTL

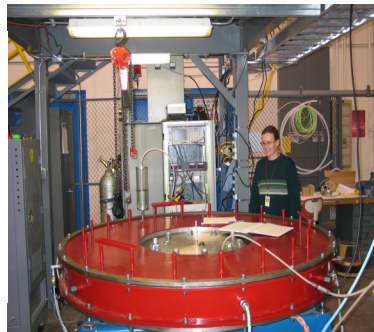

LTD driver



Shock Mitigation

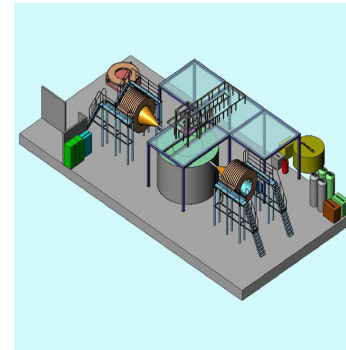

Z-PoP

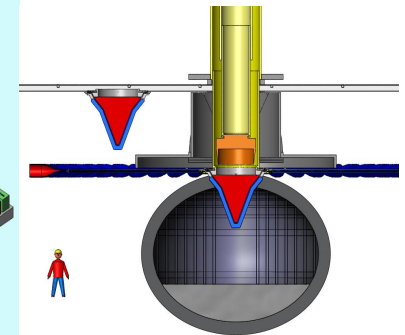

Chamber

- **Substantial Progress is being made in all areas of Z-IFE**
- **Future of Z-IFE is uncertain**

Z-PoP Movie

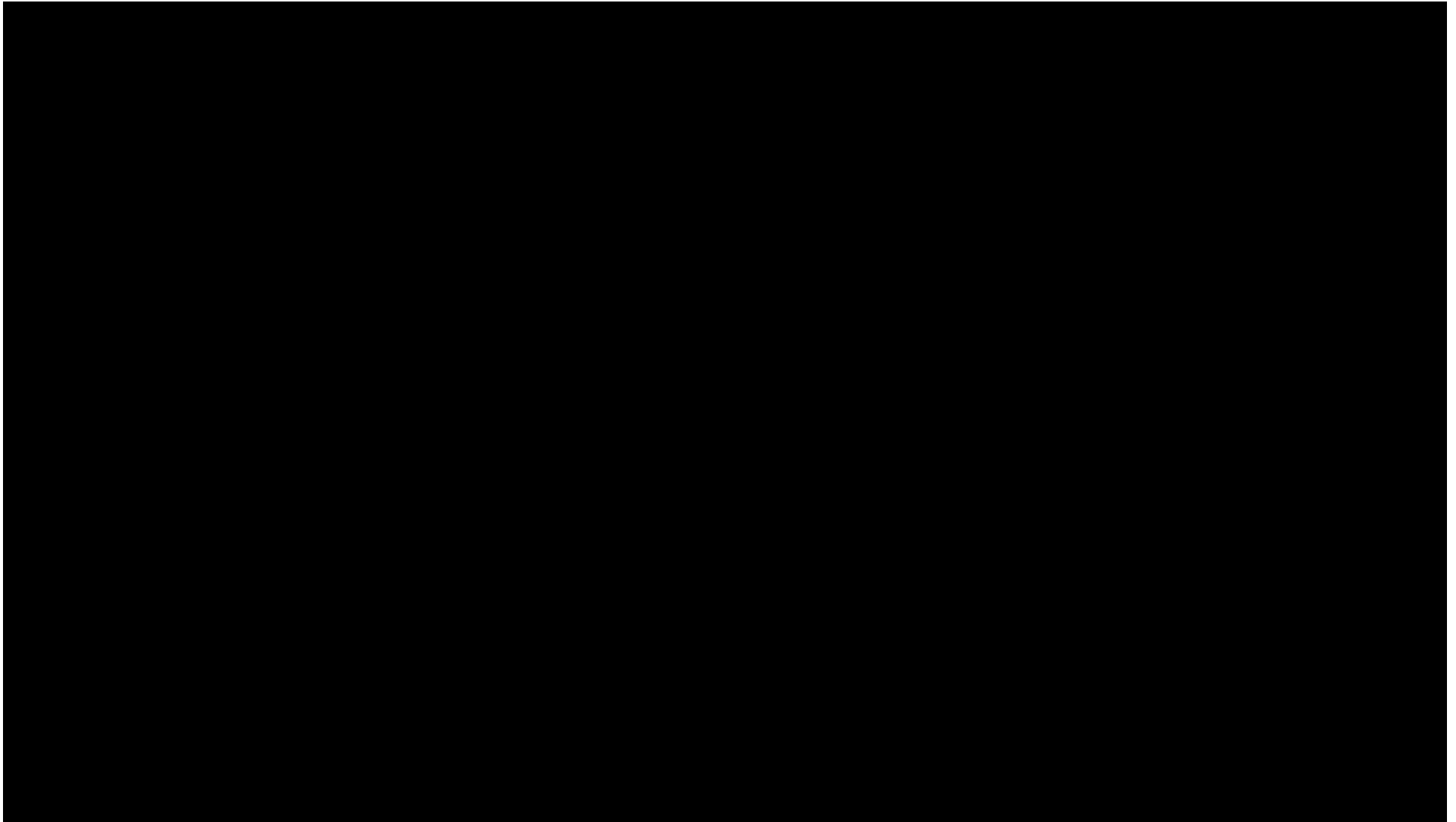



MITL/RTL Issues for 20 MA \Rightarrow 60 MA \Rightarrow 90 MA (now on Z) (high yield) (IFE)

SNL, VOSS, NRL, Kurchatov

- Issues that become most critical near the target:
- Surface heating, melting, ablation, plasma formation
- Electron flow, magnetic insulation
- Conductivity changes
- Magnetic field diffusion changes
- Low mass RTL material moves more easily
- Possible ion flow

I	20 MA	60 MA	90 MA
R_{array} (z-pinch)	? 2 cm	? 2 cm	? 5 cm
$I / (2 ? R_{array})$? 1.6 MA/cm	? 4.8 MA/cm	? 2.9 MA/cm
MITL	Works on Z	?	?
RTL	?	?	?

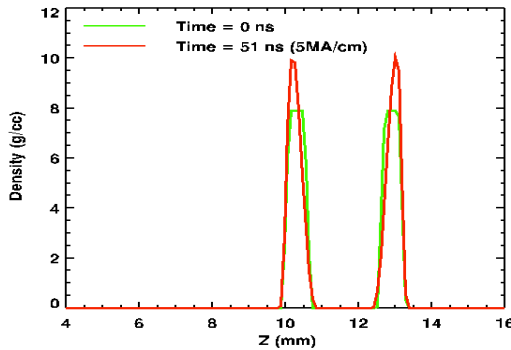

ALEGRA MHD simulations of thin-walled (0.6 mm thick), small AK gap (2 mm) at 60 MA show no disruption at 5 MA/cm

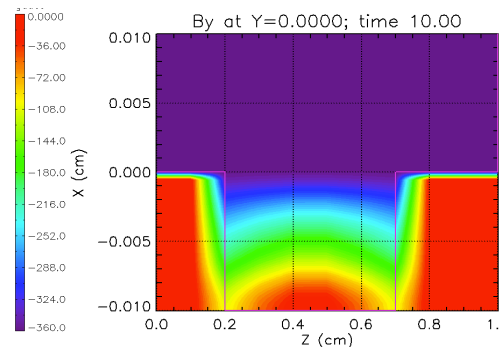

Scaling of LSP simulations for 90 MA at 2.9 MA/cm show acceptable cathode B field penetration (1-1.6 $\mu\text{m}/\text{ns}$ for 100 ns rise)

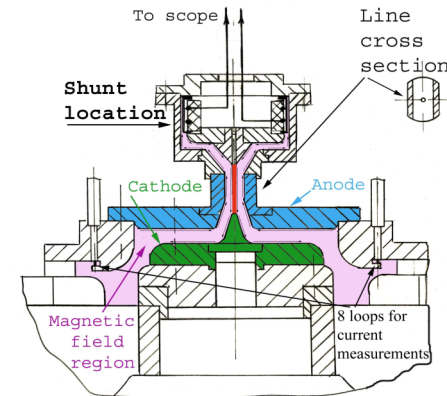

Experiment on S-300 at Kurchatov at 6 MA/cm shows plasma did not reconnect the MITL gap

Present experiments and simulations indicate RTLs should work at 5 MA/cm or more