

# Is Anybody Out There?

## SETI Instrumentation

Dan Werthimer

Space Sciences Lab  
University of California, Berkeley

<http://seti.berkeley.edu/>



## CASPER:

### Center for Radio Astronomy Signal Processing and Electronics Research

Chen Chang, Henry Chen, Daniel Chapman, Christina DeJesus,  
Pierre Droz, Jeff Mock, Aaron Parsons, Andrew Siemion

## SETI – Space Sciences Lab

David Anderson, Bob Bankay, Court Cannick, Jeff Cobb,  
Kevin Douglas, Eric Korpela, Matt Lebofsky, Mike Lampton, Dick Treffers

## Radio Astronomy Lab

Don Backer, Leo Blitz, Dave Deboer, Paul Demorest, Matt Dexter,  
John Dreher, Carl Heiles, David McMahon, Jack Welch, Mel Wright, Lynn Urry

## Berkeley Wireless Research Center

Bob Broderon, John Wawrzynek



# Early SETI Instrumentation



Karl Gauss 1820



NOT FUNDED

Joseph Von Littron ~1840

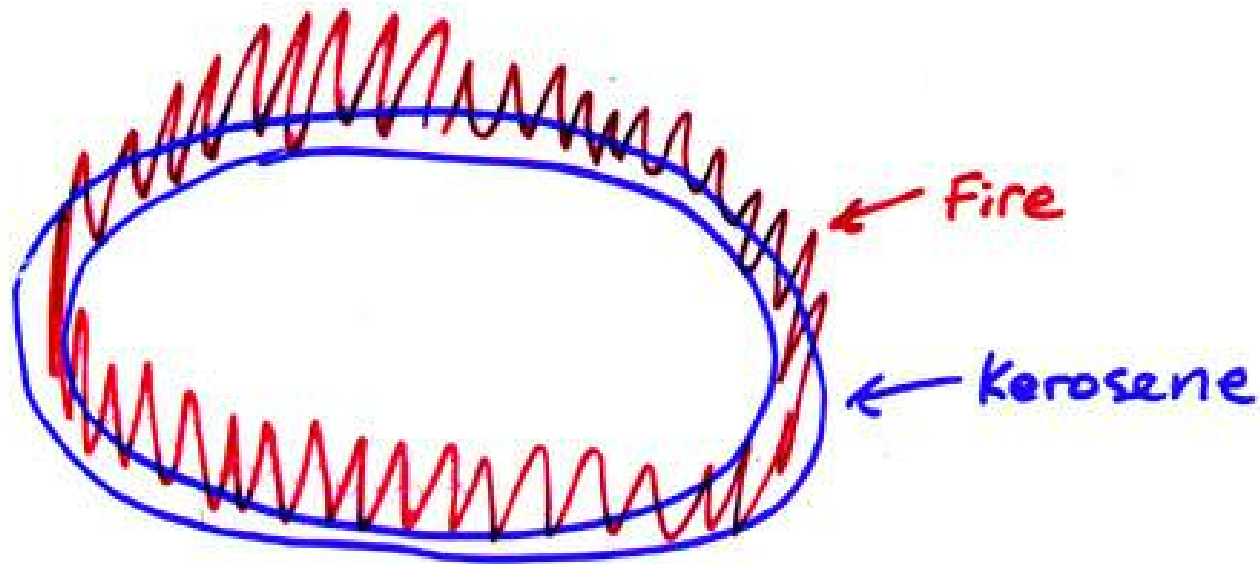

← 20 mi →



NOT FUNDED

Charles Cros 1869





NOT FUNDED

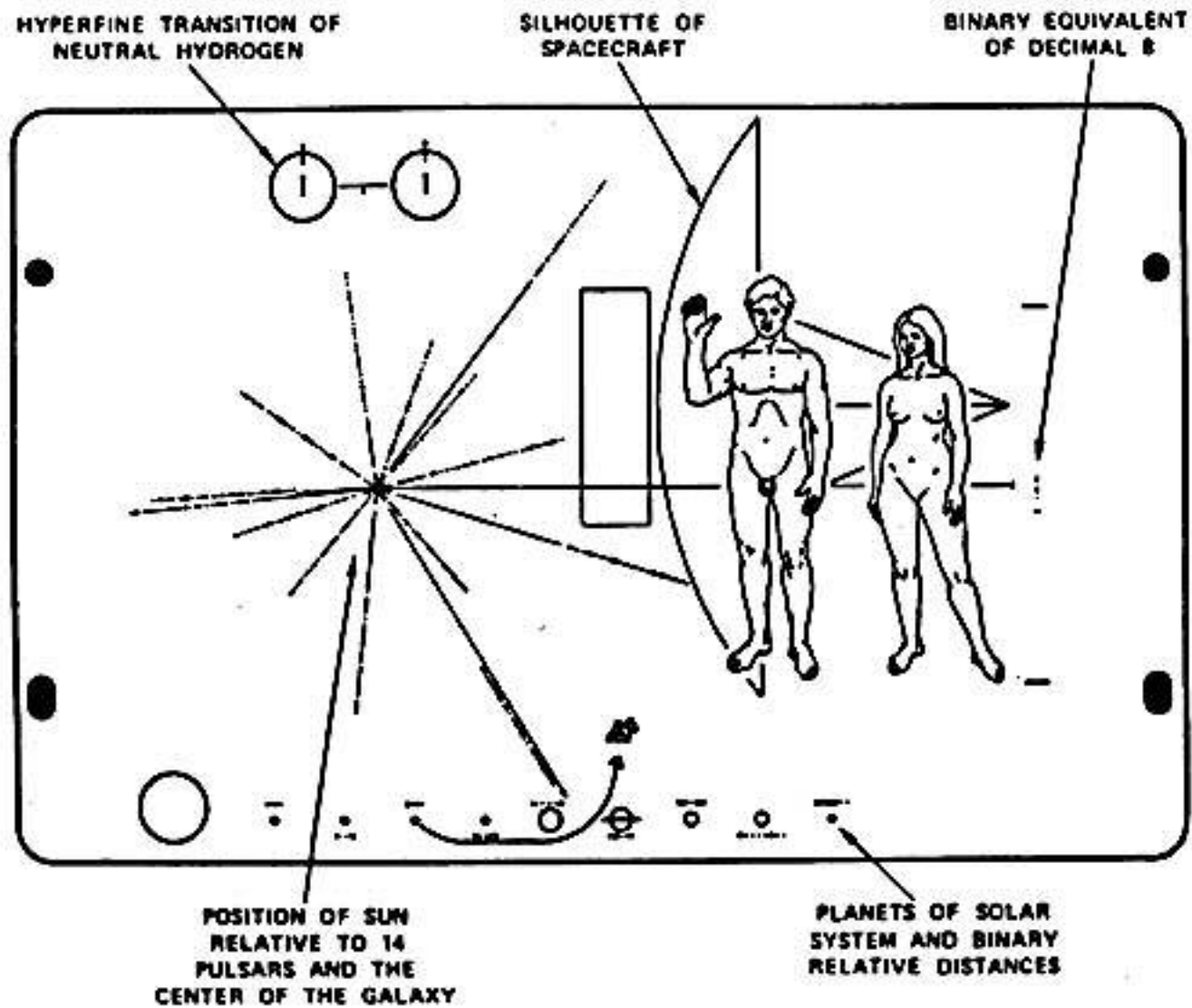

Figure 54.1. The engraved aluminum plate carried aboard Pioneer 10. It contains information on the position, epoch, and nature of the spacecraft.

Porno in space:

**FUNDED!**

# Drake Equation

- $N = R f_s f_p n_e f_l f_i f_c L$
- $N$  = number of communicating civilizations in our galaxy





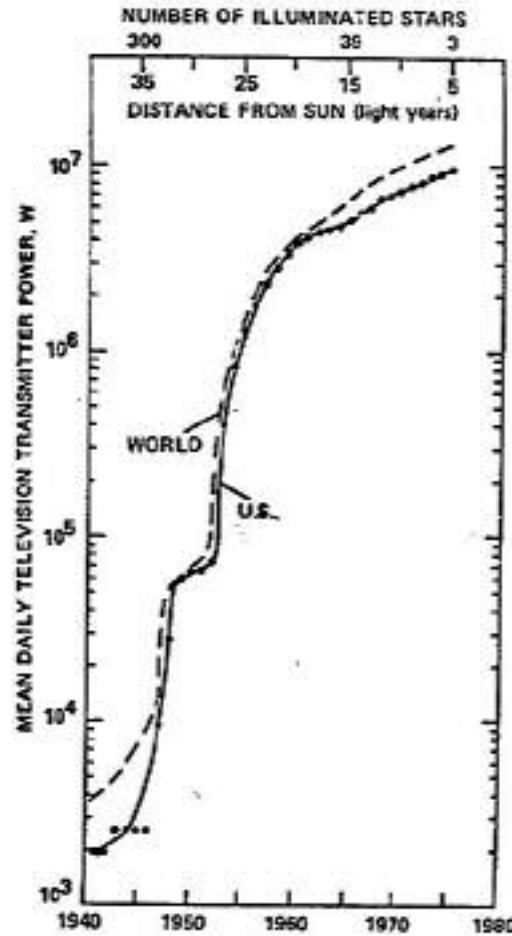
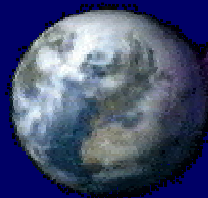

Figure 1. Estimated growth in time-averaged transmitted power since TV broadcasting began. The solid curve for the United States is reasonably accurate since starting dates for all stations are available, but it was still necessary to use a model for the growth of transmitter power and daily broadcast hours for each station. The dashed curve for the entire world is correct for 1975 and only estimated for earlier dates. The increasing number of stars bathed by the expanding power bubble (as of 1980) is indicated at the top.



SETI

The Search for Extraterrestrial Intelligence



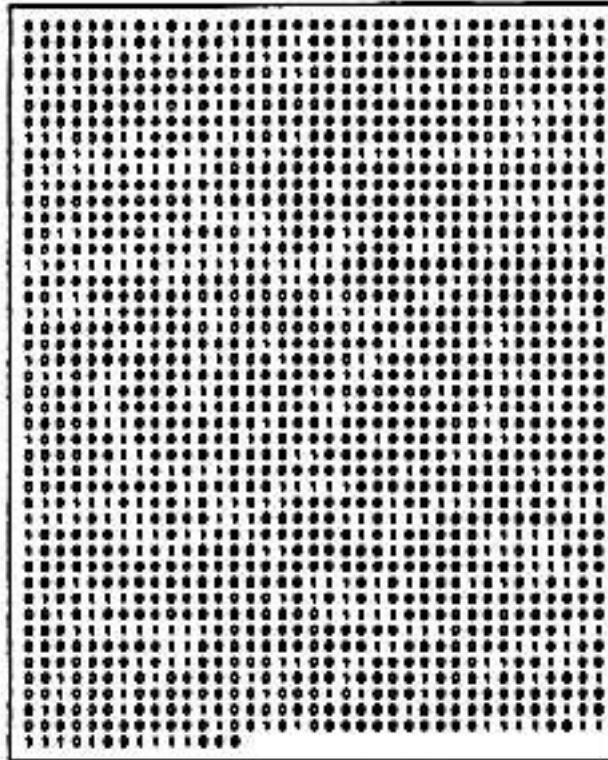

Figure 58.1. The 1679 character message transmitted on November 16, 1974. The characters were sent sequentially, with the transmitter frequency switching between two nearby radio frequencies to perform the transmission of a "0" or a "1."



Figure 58.2. The message of Figure 58.1 laid out in a format of 73 lines of 23 characters per line. Zeros are shown as white, and ones as black. The first character sent is in the upper right-hand corner, and the message reads from right to left and down.



# Signal Types

1. **Artifact** (radio, radar, ~TV, ????)
2. **Deliberate** (easy to decode, pictures, language lessons)

First civilization we contact is likely to be a billion years ahead of us. (ray norris, 2002)





# First Radio SETI

- Nikola Tesla (1899)
  - Announces “coherent signals from Mars”
- Guglielmo Marconi (1920)
  - Strange signals from ET
- Frank Drake (1960)
  - Project Ozma
  - one channel, 1420-1420.4 MHz



## Radio - Targeted Search Strategy

Project Phoenix - Seti Institute

## Radio - Sky Survey Strategy

Serendip, SETI@home - UC Berkeley

Southern Serendip - Australia

Meta II - Argentina

Seti Italia - Bologna

## Optical - Targeted

UC Berkeley - Pulse and Continuous

Lick Observatory – Pulse

Harvard – Pulse, Sky survey 2006

Princeton - Pulse



# UC Berkeley SETI Programs

Name	Time Scale	Search Type
SERENDIP	seconds	radio sky survey
SETI@home	mS - seconds	radio sky survey
Astropulse	nS - mS	radio sky survey
SEVENDIP	nS	visible targetted
SPOCK	1000 seconds	visible targetted
DYSON		IR targetted



# SERENDIP

Search for  
Extraterrestrial  
Radio  
Emissions from  
Nearby  
Developed  
Intelligent  
Populations

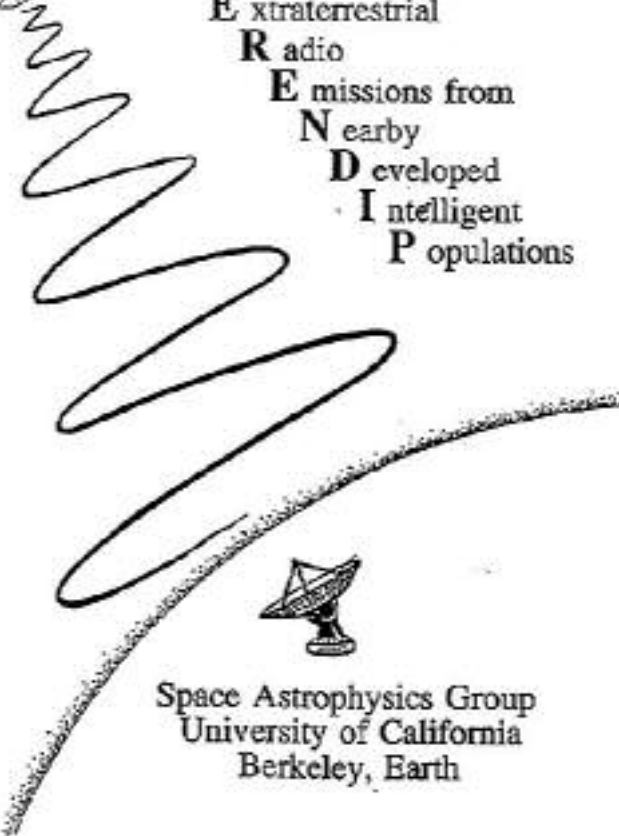

Space Astrophysics Group  
University of California  
Berkeley, Earth

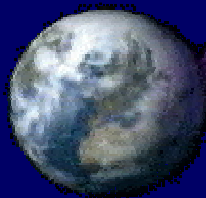

SETI@

The Search for Extraterrestrial Intelligence



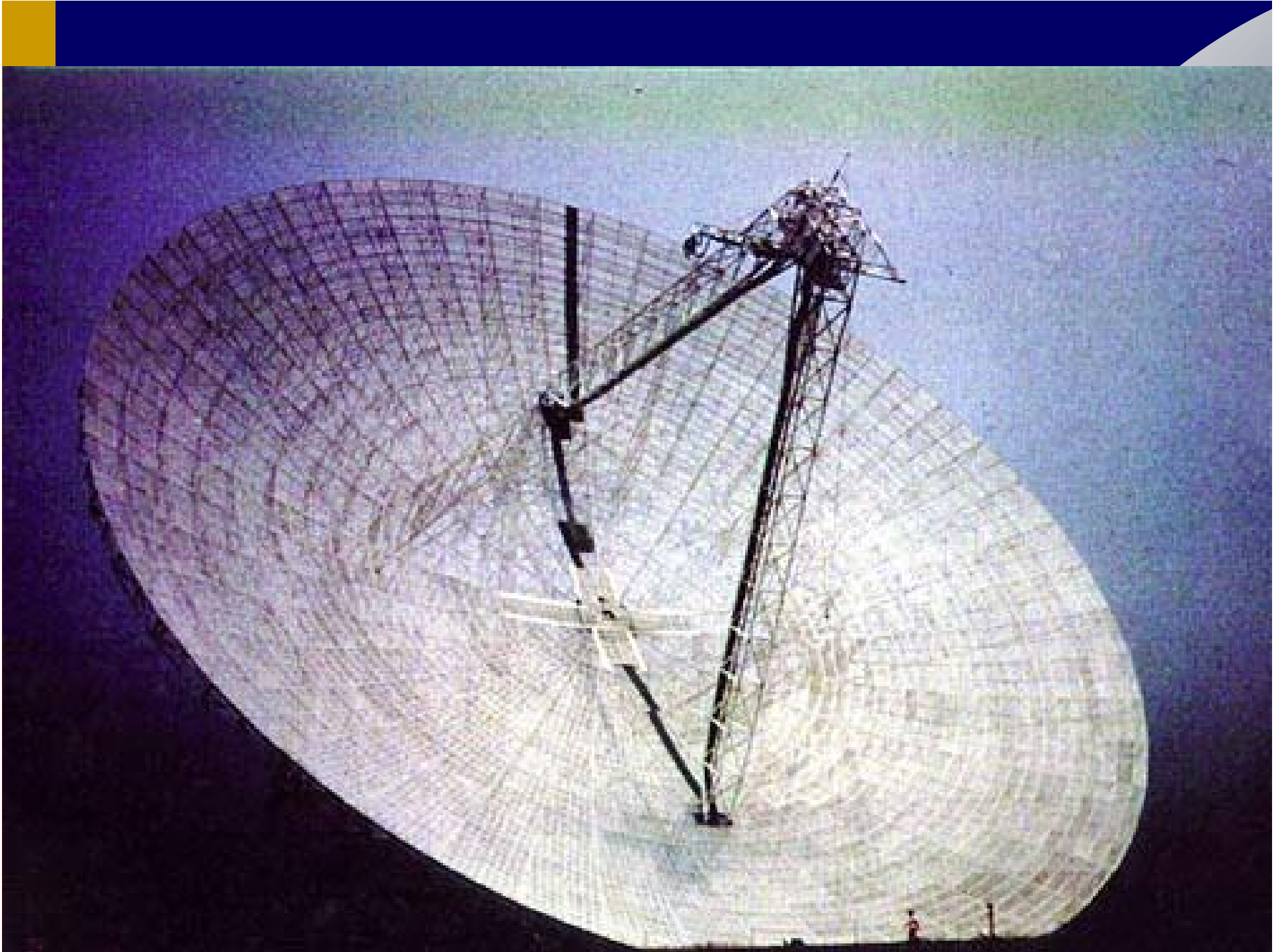



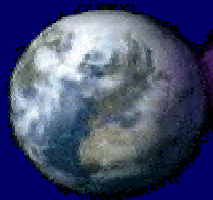

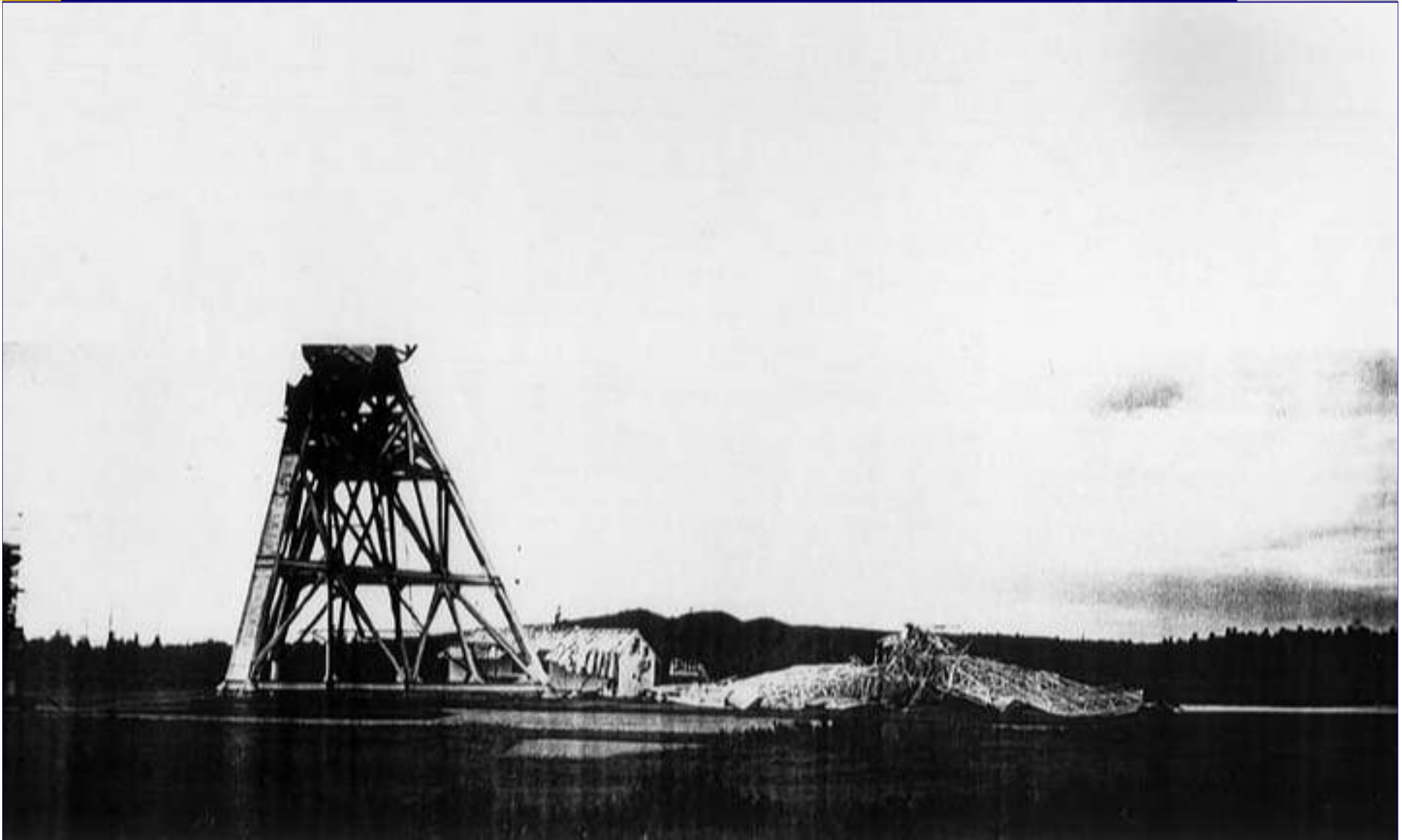

U.S. AIR FORCE  
The Search for Extraterrestrial Intelligence





America's most powerful radio telescope IS...

WORLD HEADLINE NEWS  
 Sun 21, 1951 P. 2

# ZAPPED!

... by hostile space aliens!



BEFORE ▲

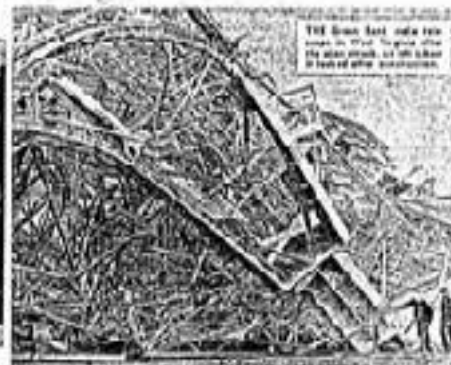

THE Green Bank radio telescope after the alien attack. It has been destroyed after receiving a radio signal.

▲ AFTER ▶

Space aliens zapped the enormous radio telescope at Green Bank, W. Va., with a powerful laser to keep scientists from monitoring their activities in the northern hemisphere. That's the claim of some astronomers who say the destruction of the \$200,000 instrument on November 13 resulted in the heaviest act of extraterrestrial aggression in the history of the world.

It's true that extraterrestrial life has not been proved and accepted people believe in it. But the fact that some have been found among the stars is a possibility, says Dr. Van Allen.

There is no doubt that the telescope was destroyed by a powerful laser beam. The structure was made of wood and metal and was very old. It was destroyed by a powerful laser beam. The structure was made of wood and metal and was very old. It was destroyed by a powerful laser beam.

**Brave dog**  
 A German shepherd dog named Rex was the first to be killed by an extraterrestrial laser beam. The dog was killed by a powerful laser beam. The dog was killed by a powerful laser beam.

IT'S SERENDIPS' FAULT!

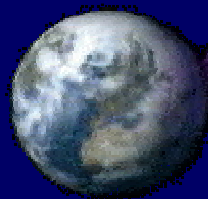

SETI

The Search for Extraterrestrial Intelligence



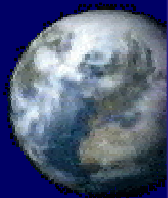

# SERENDIP IV

Photos Courtesy NAIC Arecibo Observatory, a facility of the NSF



- 168M channels
- 100 MHz Band centered on 1420 MHz
- Carriage House 1 line feed
- Operating since 1997



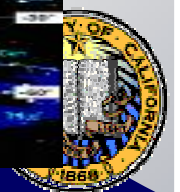
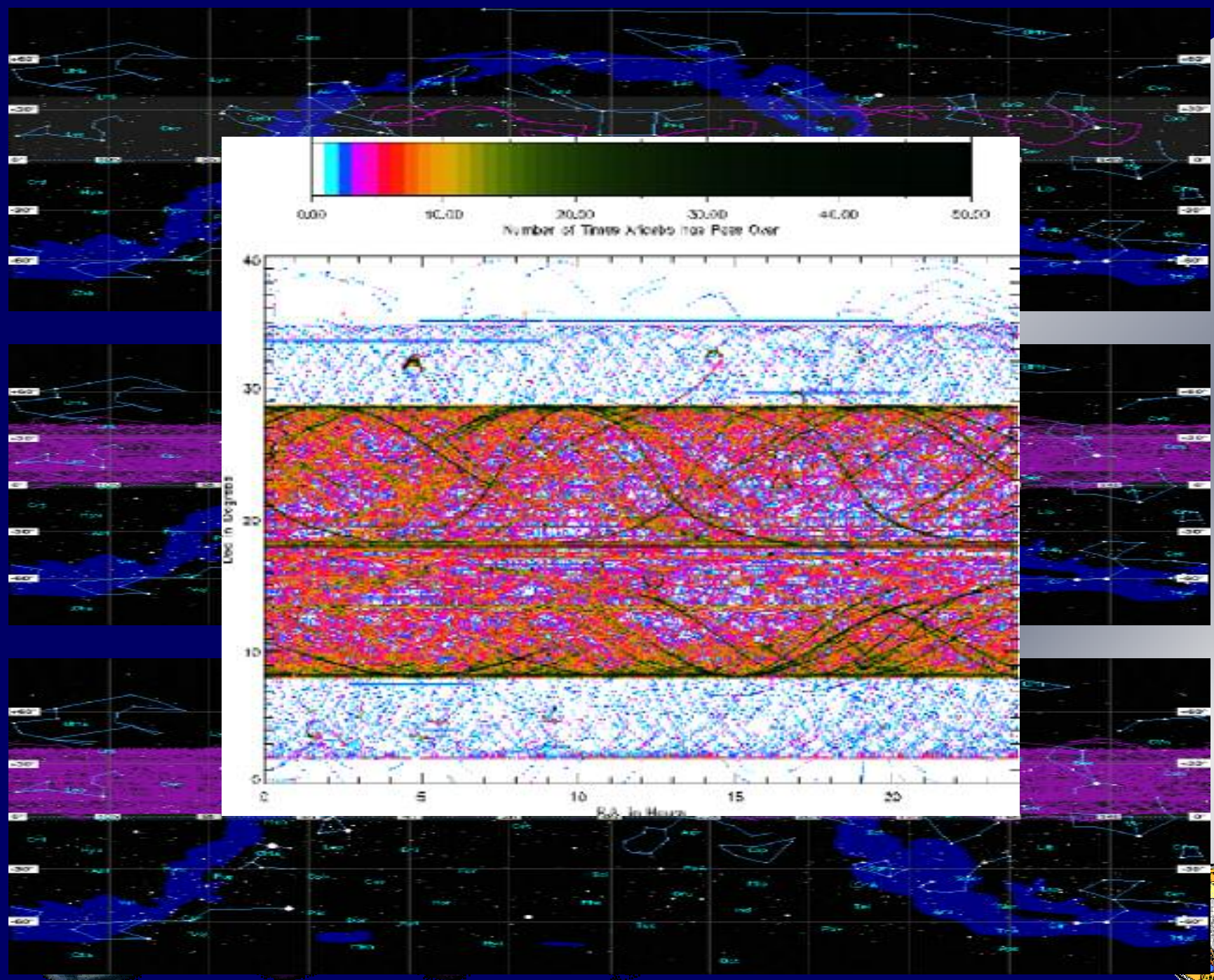

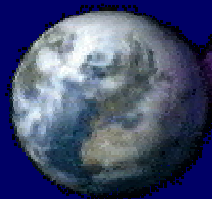

**SETI**  
The Search for



Sample III  
Magnification: Auto

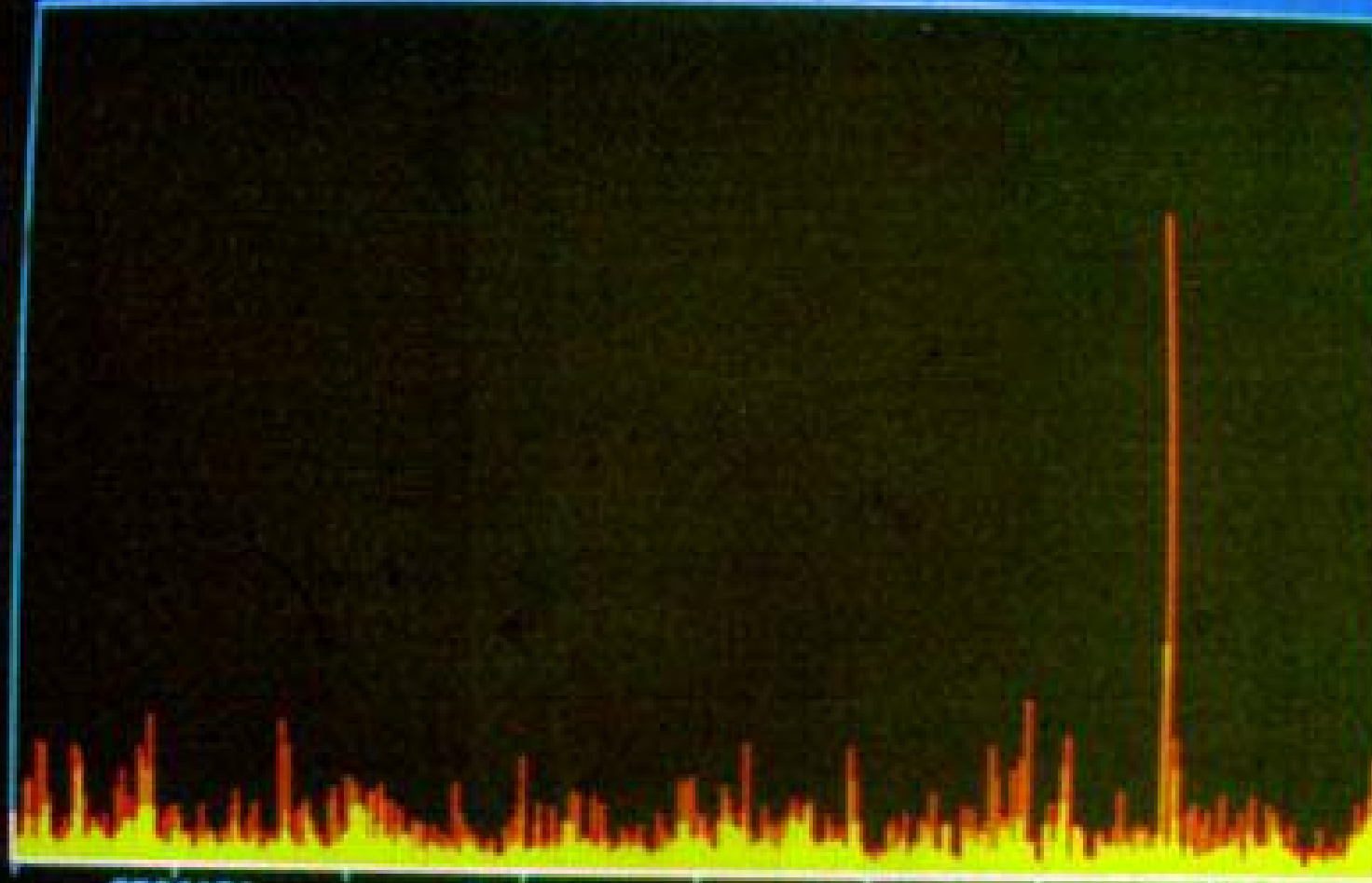

2264191

2264447

2264703

2264959

Power (f) vs Bin Number (i)

X	-	min:	2264864
X	-	max:	2264959
Y	-	min:	0
Y	-	max:	150
File	pos:		5

File  
View  
Zoom  
Cursor  
Help

6/9/93

## 30 Trillion Fruitless Tries

But scientists keep searching for extraterrestrial intelligence

By Charles Peitz  
Chronicle Science Writer

Astronomers in Berkeley, hoping to be the first everlings to detect signals from alien civilizations, said they have in one year accumulated a success rate of approximately zero for 30 trillion.

"I think it is going to be a long search for everybody," said Stuart Rowyer, an astronomer from the University of California at Berkeley and leader of one of the more ambitious Search for Extraterrestrial Intelligence (SETI) projects under way worldwide.

The Berkeley program is called SERENDIP III. It was started one year ago by piggybacking on signals being gathered for other projects by astronomers using the 1,000-foot-wide Arecibo Radio Telescope in Puerto Rico.

The extravagantly contrived acronym stands for Search for Extraterrestrial Radio Emissions from Nearby Intelligent Populations. It is the third such program in 15 years at Berkeley but has a sensitivity many times better than earlier ones.

A sophisticated electronics system studies a portion of the radio spectrum, between 424 and 426 megahertz, not far from those used for television and some radar. It monitors 4 million channels within that portion of the spectrum, repeating the analysis every 1.7 seconds. In the 3,600 hours of operation so far, nothing definite has turned up.

However, said Chuck Donnelly, project software director, the electronics automatically keeps a running list of 100 or so of the most peculiar signals for further analysis. At the moment, the list of "candidates" stands at 104.

Chances are, Rowyer said, that like all the thousands of previous candidates rejected, the candidates will turn out to be stray signals from airplanes, someone's washing machine, or just the natural "burp" of a distant star.

Within the bias of natural radio emanations from stars and colliding galaxies, scientists hope to pick up the pure tones or tightly tuned signals that may signal an intelligence out there.

The Berkeley SETI scientists presented their first year's report as part of the meeting on campus of the American Astronomical Society. Other major SETI projects include one managed by the NASA Ames Research Center and the Jet Propulsion Laboratory that looks for signals much more powerful than those detectable by the Berkeley group.

"We are looking for the leakage of radio or TV signals from some other civilization," Rowyer said. Just as Earth's radar signals have been spreading outward for 56 years — with TV shows such as "I Love Lucy" reaching tens of thousands of stars — corresponding signals from far away may be washing over Earth. "It just is not so easy to find them," Rowyer said.

Now  $10^{18}$  Fruitless Tries  
(one million trillion)

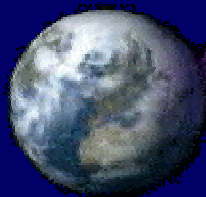

SETI

The Search for Extraterrestrial Intelligence



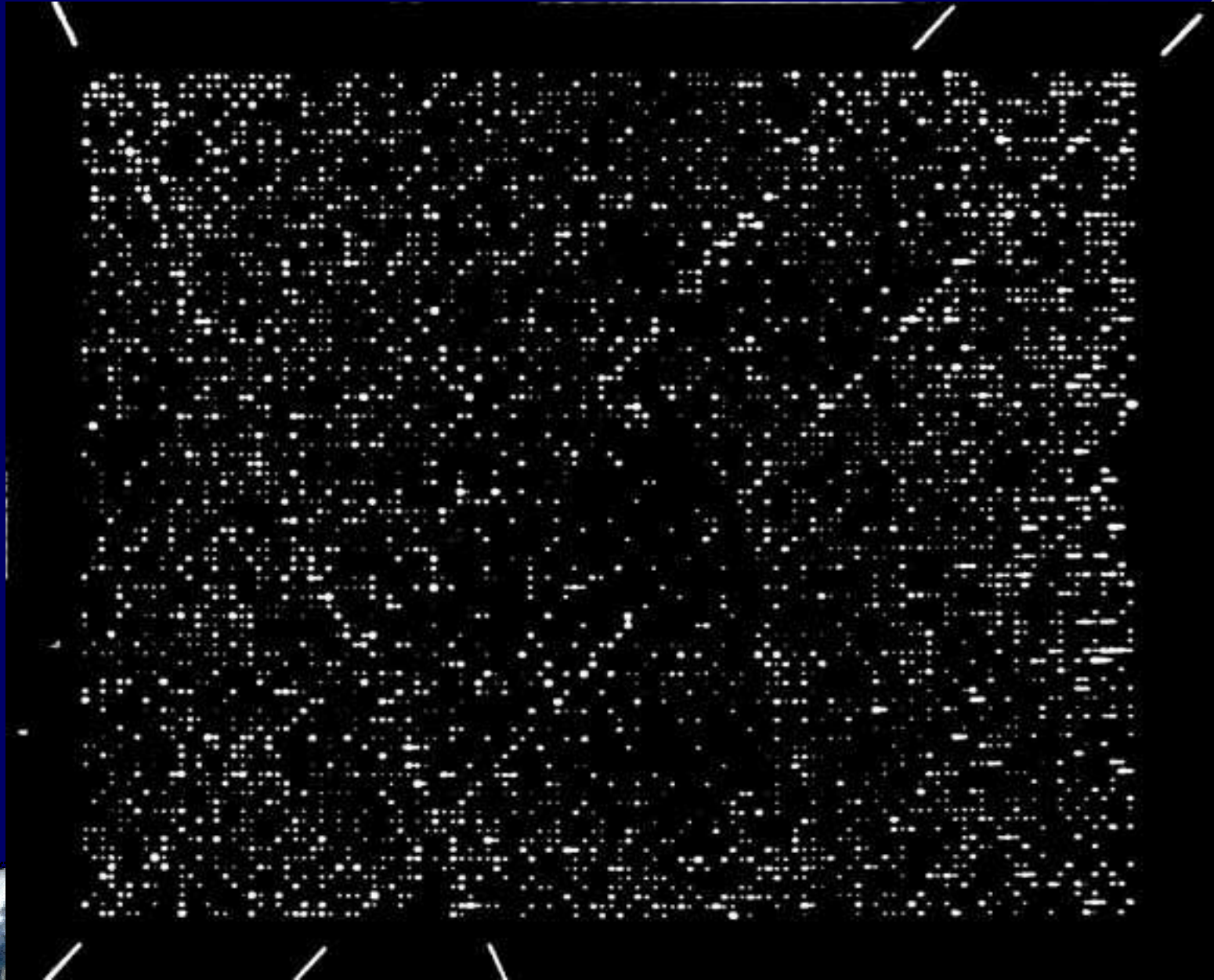



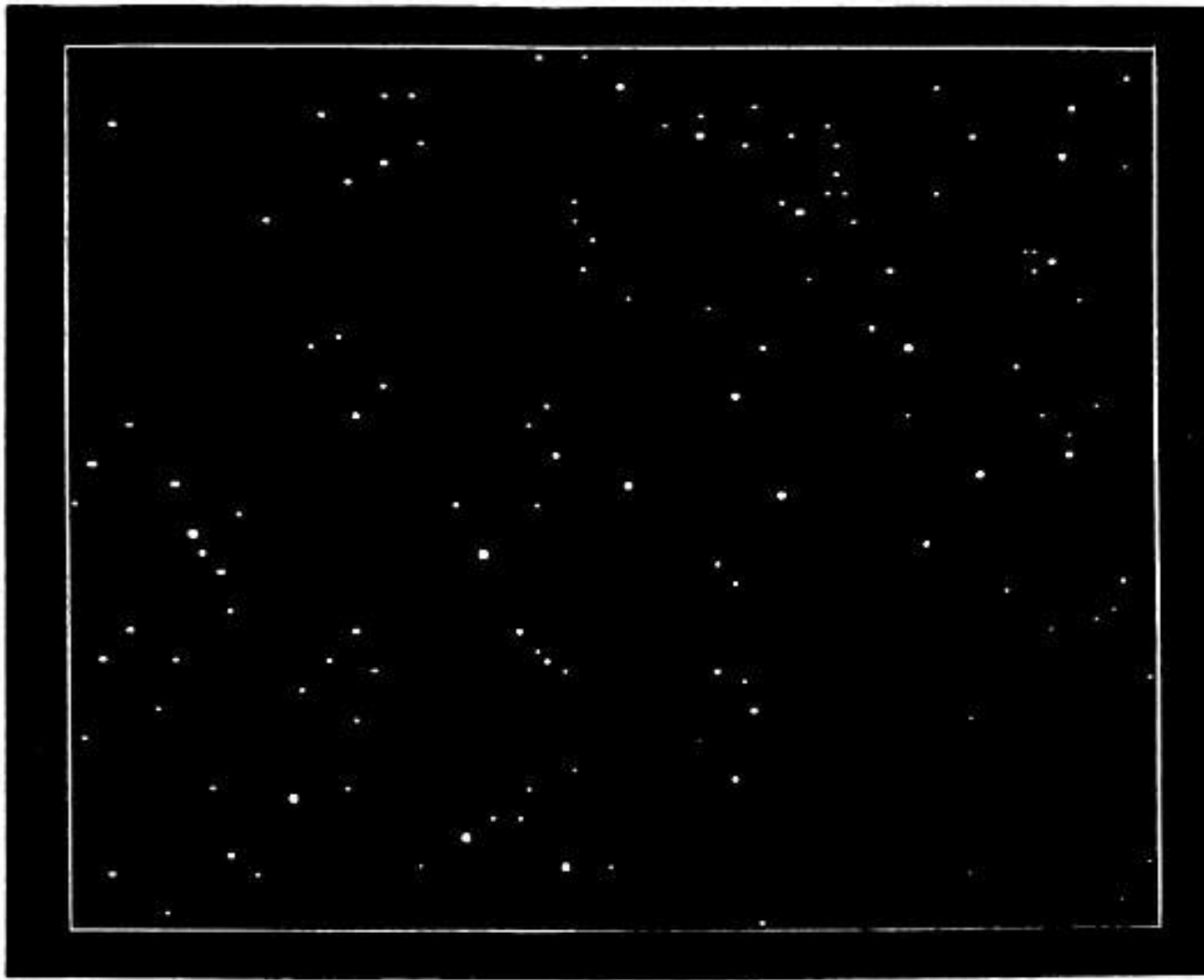

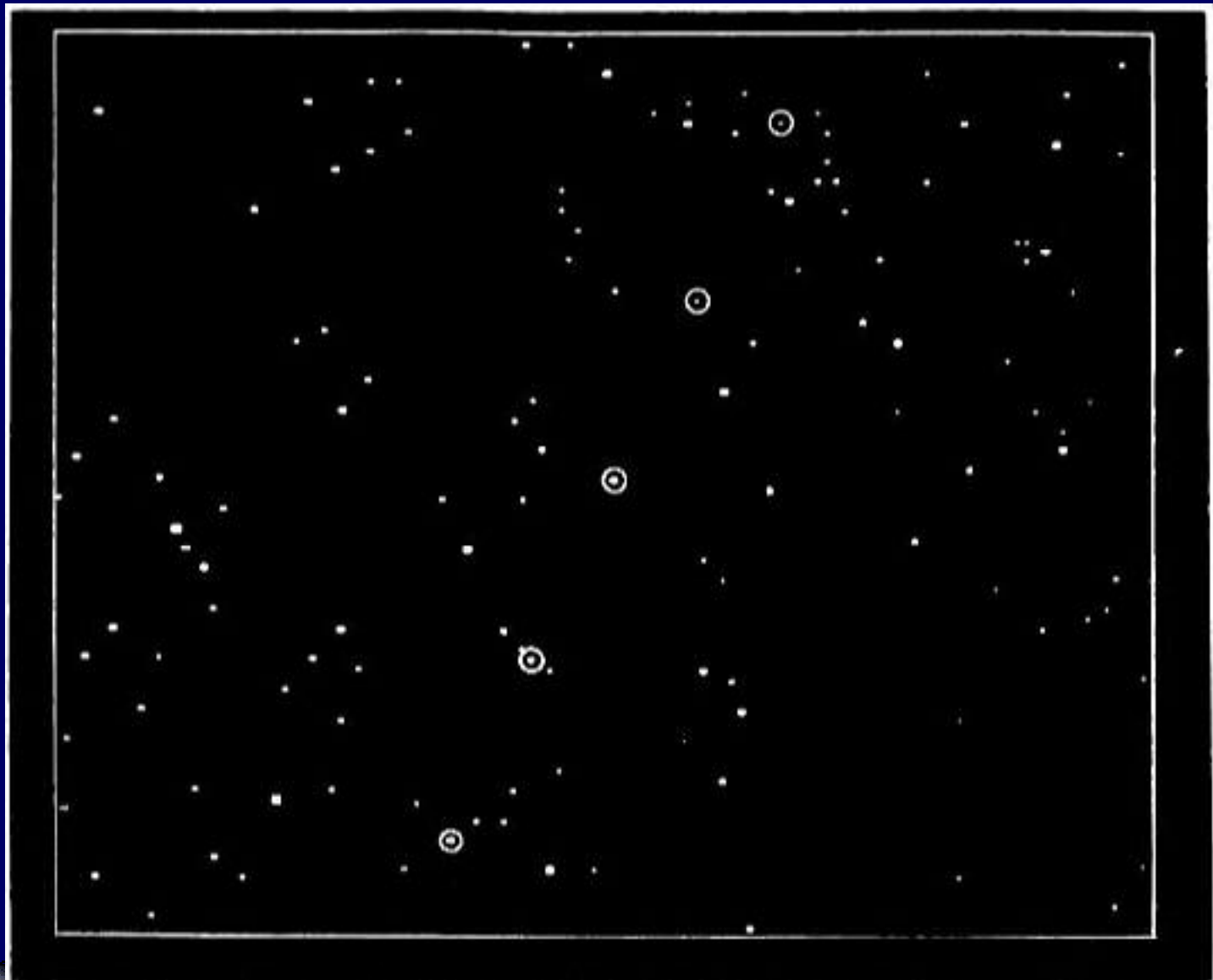

Fig. 5



# Why SETI@home?

- Coherent Doppler drift correction
  - Narrower Channel Width->Higher Sensitivity
- Variable bandwidth/time resolution
- Search for multiple signal types
  - Gaussian beam fitting
  - Search for repeating pulses

Problem: Requires TFLOP/s processing power.

Solution: Distributed Computing



# The SETI@home Client

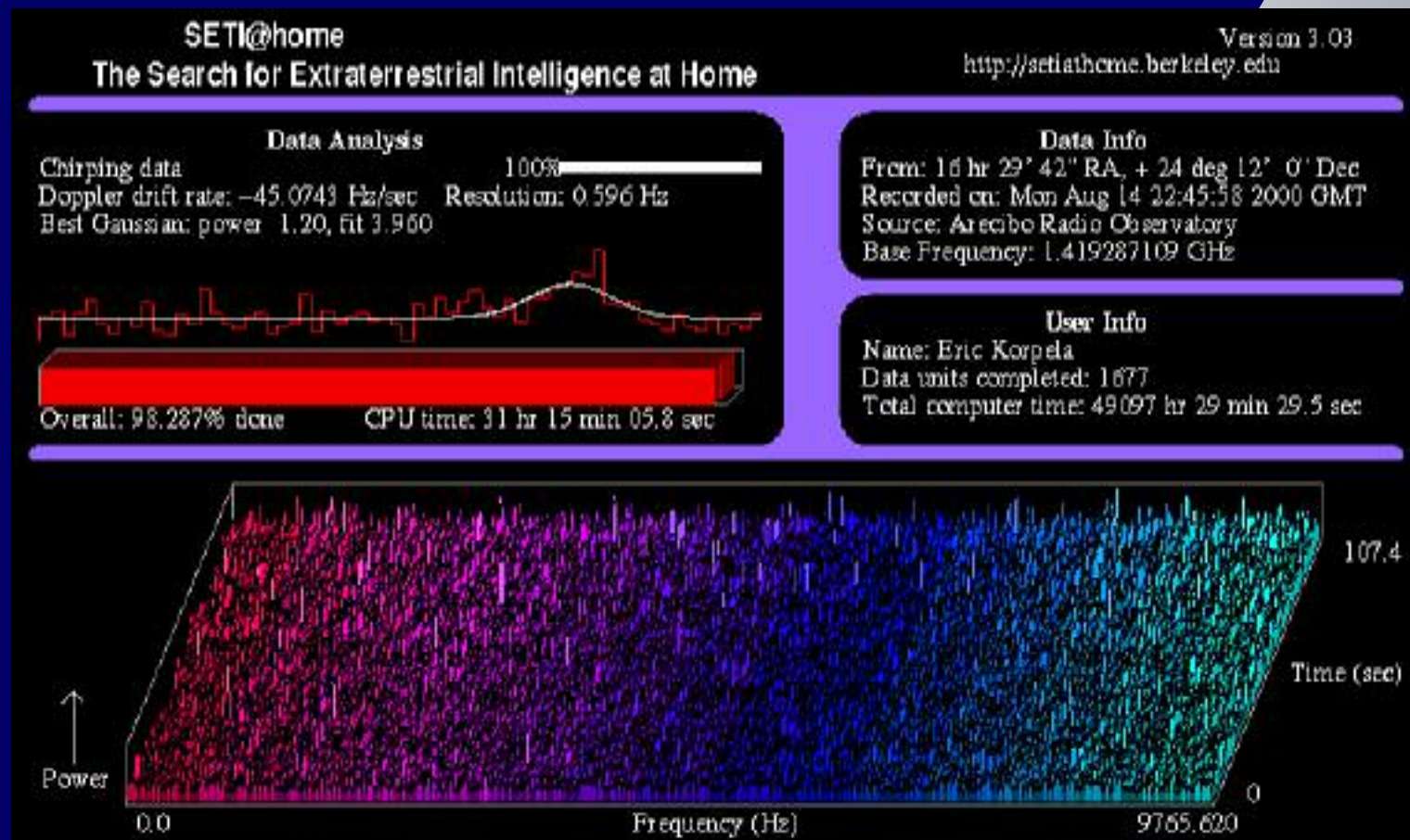

# SETI@home Statistics

## TOTAL

## RATE

5,464,550 participants  
(in 226 countries)

2,000 per day

2.3 million years  
computer time

1,200 years per day

$4 \times 10^{21}$  floating point  
operations

65 Tera-flops





# SETI@home

The Search for Extraterrestrial Intelligence

User Profile: **Lynne Rutter**

RECOMMEND

[what is recommend?](#)

VOTE TO REJECT

[what is vote to reject?](#)



**Country:** United States

**Number of Results:** 469 **CPU Time Per Result:** 17 hr 23 min 27.7 sec

**Last Result Time:** Sun Nov 25 21:32:35 2001 **Date Registered:** Sun May 16 21:41:00 1999

## BACKGROUND

I am an artist living in San Francisco. I have my own business painting murals and trompe l'oeil, and most of my life is spent breathing the rarified air of the art / interior design world along with the dust in my studio or worksite. You can see my paintings at [www.lynnerutter.com](http://www.lynnerutter.com). My other interests are many and varied, and include travelling; gardening and raising exotic plants; skiing; skin diving; rock climbing; camping in Yosemite with sexy genius geeks; and collecting shoes. I love to read (anything from "Bridget Jones' Diary" to Dickens to Susan Minot) and there is no clear pattern to my music collection (Beethoven, Buzzcocks, Kate Bush, Ralph Stanley, Stravinsky, Showboat) although it is stored alphabetically and most of it is on vinyl. My favourite artist, author, or composer changes every month. I am fascinated by the stars, and by all forms of mythology.

## SETI THOUGHTS

I have been running SETI@home on my iMac since May of 1999. It is arrogant to assume we (humans) are alone in the universe. I hope there are other worlds and other lives out there, and that they are more intelligent and respectful than we are. I don't think we are ready to send a 'beacon' out into space, as we are already transmitting a lot of crap - to each other - and any advanced intelligent life would know that we may not yet be developed enough for meaningful contact. The Search is important, however, and I believe scientific proof of the existence of ETI could bring about real positive change on this world. Furthermore, the distributed computing aspect of SETI@home is a worthwhile pursuit - think of the millions of otherwise idle PCs that can be used to solve big problems right here on Earth.

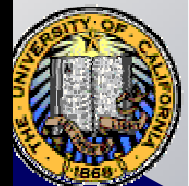

- Primary Schools
  - Top 200
  - A B C D E F G H I J K L M N O P Q R S T U V W X Y Z 0 1 2 3 4 5 6 7 8 9 Other
- Secondary Schools
  - Top 200
  - A B C D E F G H I J K L M N O P Q R S T U V W X Y Z 0 1 2 3 4 5 6 7 8 9 Other
- Junior Colleges
  - Top 200
  - A B C D E F G H I J K L M N O P Q R S T U V W X Y Z 0 1 2 3 4 5 6 7 8 9 Other
- Universities and Departments
  - Top 200
  - A B C D E F G H I J K L M N O P Q R S T U V W X Y Z 0 1 2 3 4 5 6 7 8 9 Other
- Small Companies (< 50 employees)
  - Top 200
  - A B C D E F G H I J K L M N O P Q R S T U V W X Y Z 0 1 2 3 4 5 6 7 8 9 Other
- Medium Companies (50-1000 employees)
  - Top 200
  - A B C D E F G H I J K L M N O P Q R S T U V W X Y Z 0 1 2 3 4 5 6 7 8 9 Other
- Large Companies (> 1000 employees)
  - Top 200
  - A B C D E F G H I J K L M N O P Q R S T U V W X Y Z 0 1 2 3 4 5 6 7 8 9 Other
- Clubs
  - Top 200
  - A B C D E F G H I J K L M N O P Q R S T U V W X Y Z 0 1 2 3 4 5 6 7 8 9 Other
- Government Agencies
  - Top 200
  - A B C D E F G H I J K L M N O P Q R S T U V W X Y Z 0 1 2 3 4 5 6 7 8 9 Other
- All Groups
  - Top 200
  - A B C D E F G H I J K L M N O P Q R S T U V W X Y Z 0 1 2 3 4 5 6 7 8 9 Other

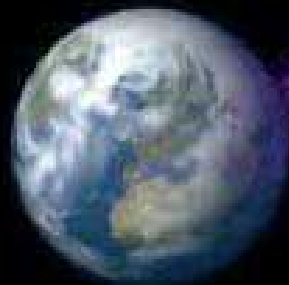

# SETI@home

The Search for Extraterrestrial Intelligence

## Large Company Teams

Last updated: Mon Apr 29 13:43:25 2002 UTC

Name	Members	Results received	Total CPU time	Average CPU time per work unit
1) <a href="#">Compaq Computer Corporation</a>	790	3558699	3186.750 years	7 hr 50 min 39.9 sec
2) <a href="#">Sun Microsystems</a>	476	3332359	3466.458 years	9 hr 06 min 45.0 sec
3) <a href="#">SGI SETI</a>	390	3093165	2162.647 years	6 hr 07 min 29.0 sec
4) <a href="#">IBM</a>	1078	1675466	2844.529 years	14 hr 52 min 20.3 sec
5) <a href="#">Microsoft</a>	1208	1605938	2037.371 years	11 hr 06 min 48.1 sec
6) <a href="#">Intel® Corporation</a>	475	1595846	1388.653 years	7 hr 37 min 21.6 sec
7) <a href="#">Hewlett-Packard</a>	610	1265982	1764.556 years	12 hr 12 min 35.6 sec
8) <a href="#">Apple Computer, Inc.</a>	714	841045	1381.364 years	14 hr 23 min 15.9 sec
9) <a href="#">Unisys</a>	262	775018	1031.256 years	11 hr 39 min 22.5 sec
10) <a href="#">Cisco Systems</a>	361	761009	1222.233 years	14 hr 04 min 08.9 sec
11) <a href="#">Oracle Corporation</a>	398	622979	1165.969 years	16 hr 23 min 42.8 sec







home | my eBay | site map | sign out

Browser Sell Services Search Help Community

Item view

Account with Over 7,160 Seti@home Units Seti

Item # 1310983424

Computer Services Other



Currenty **\$107.50** (reserve set yet) Time left **11M 59S**

Quantity **1** # of bids **20** bid history

Time left **2 days, 0 hours 4** Location **Virginia**



Started **Dec-16-01 14:07:08 PST** 20 mail this auction to a friend

Ends **Dec-23-01 14:07:08 PST** Watch this item

Seller (Rating) **byteseller (53) ☆**

view comments in seller's feedback profile | view seller's other auctions | ask seller a question

High bid **rockyili@seicon (1)**

Payment See item description for payment methods accepted

Shipping Will ship to United States only. See item description for shipping charges.

Seller assumes all responsibility for listing this item. You should contact the seller to resolve any questions before bidding. Auction currency is U.S. dollars (\$) unless otherwise noted.

### Description

## Over 7,160 Seti@Home Units

A unique chance to join the elite top 0.18% (or so) of all Seti users. If you want you can view this as putting you ahead of 99.82% of all Seti@home users. I am auctioning off my Seti units in hope of breaking my Seti@home habit - and hopefully recovering a (small) fraction of the money I've spent getting these units.

The Seti@home account being auctioned currently has 7,160 (as of me editing this posting) and will continue to accrue units for the

\$275.

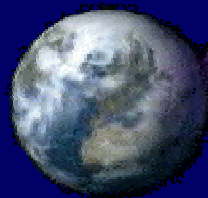

SETI

The Search for Extraterrestrial Intelligence



VOSBURG FAMILY

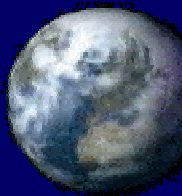

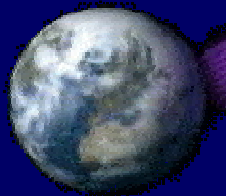
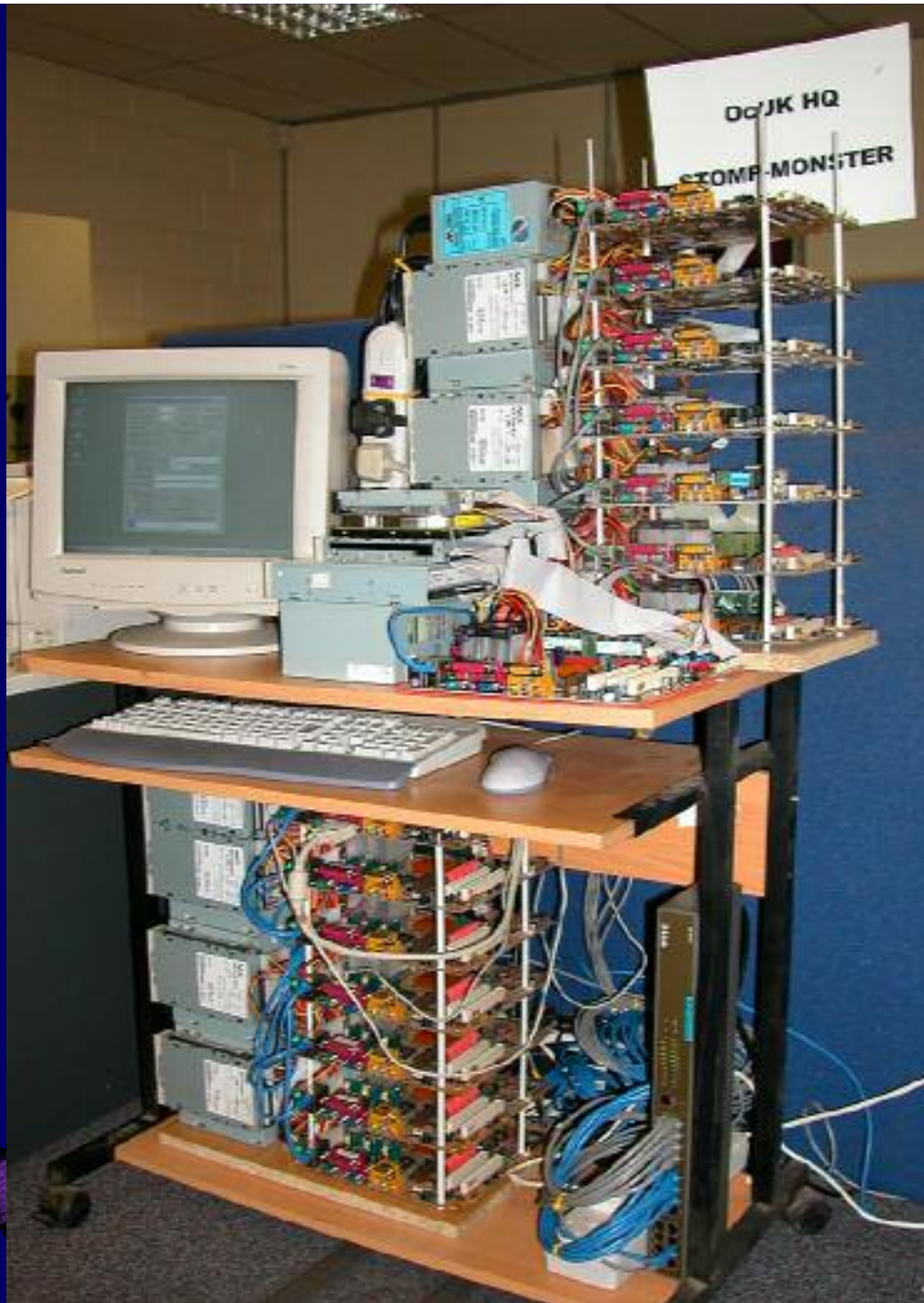

Web site: 2 million hits/day  
200,000 visitors/day

(stats & games popular; science less popular)

100,000 children, families

(including congress members and their kids)

> 7,000 schools



# Messages from Space:

## The Solar System and Beyond

Grades 5—8

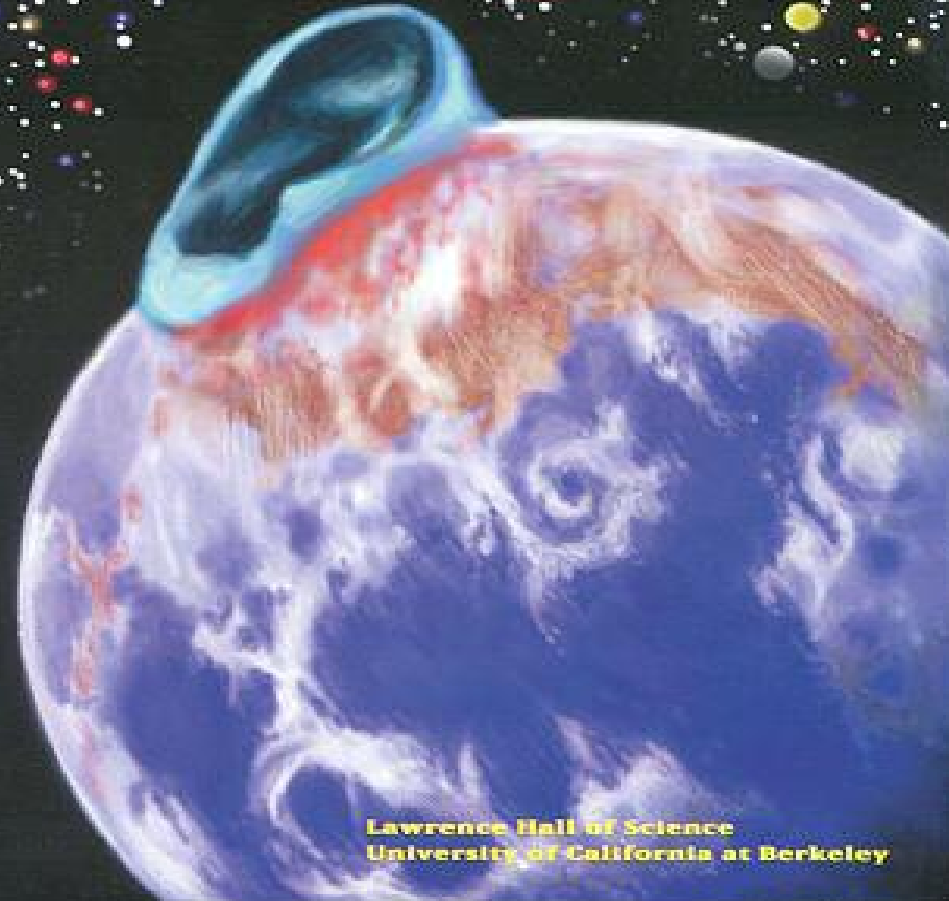

Lawrence Hall of Science  
University of California at Berkeley



# Gaussian Candidates

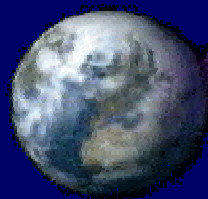
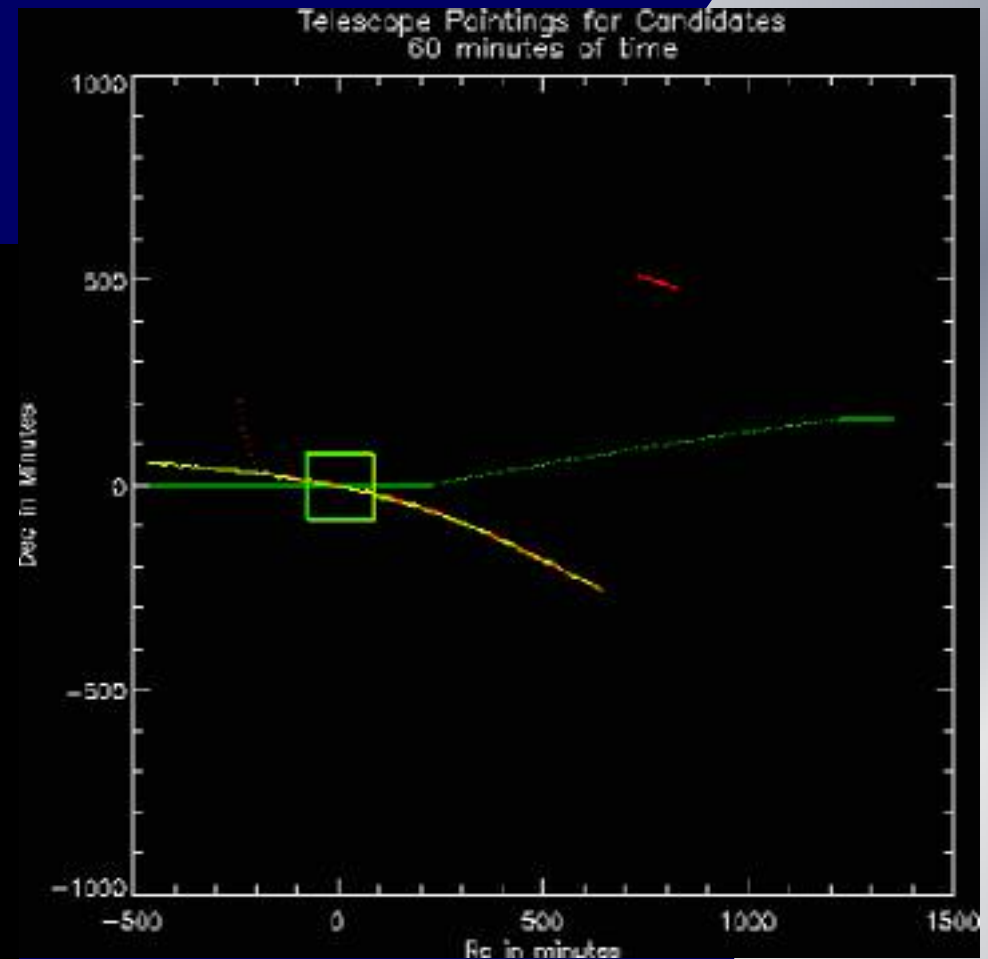
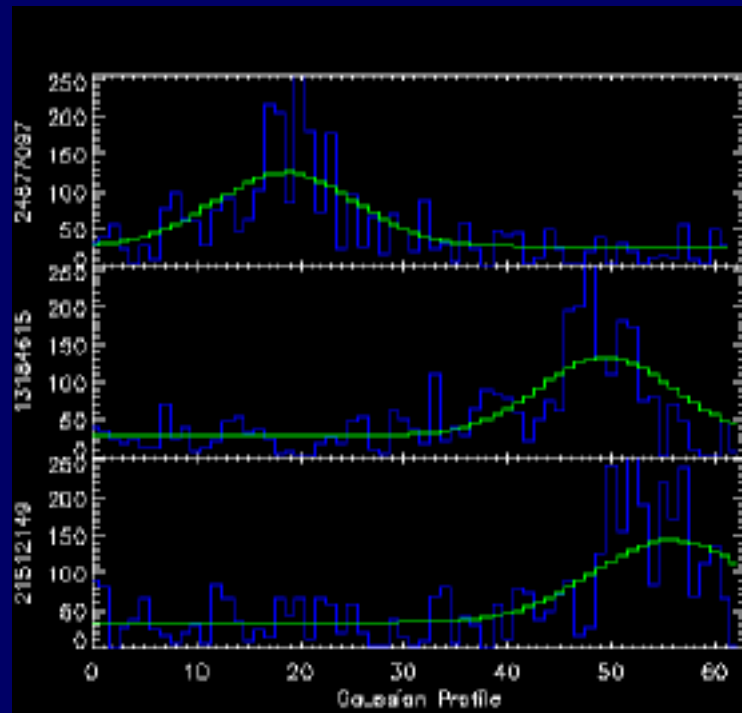

**SETI@home**

The Search for Extraterrestrial Intelligence



# BOINC - David Anderson

- Berkeley Open Infrastructure for Network Computing
  - General-purpose distributed computing framework.
  - Open source.
  - Will make distributed computing accessible to those who need it. (Starting from scratch is hard!)

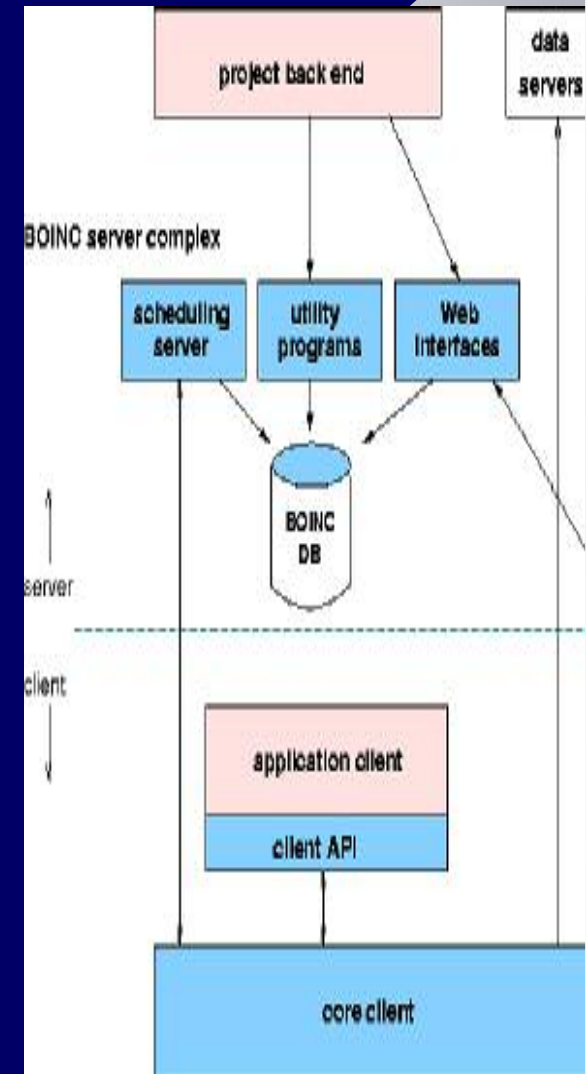

# Projects

- Astronomy
  - SETI@home (Berkeley)
  - Astropulse (Berkeley)
  - Einstein@home: gravitational pulsar search (Caltech,...)
  - PlanetQuest (SETI Institute)
  - Stardust@home (Berkeley, Univ. Washinton,...)
- Earth science
  - Climateprediction.net (Oxford)
- Biology/Medicine
  - Folding@home, Predictor@home (Stanford, Scripts)
  - FightAIDSathome: virtual drug discovery
- Physics
  - LHC@home (Cern)
- Other
  - Web indexing/search
  - Internet Resource mapping (UC Berkeley)





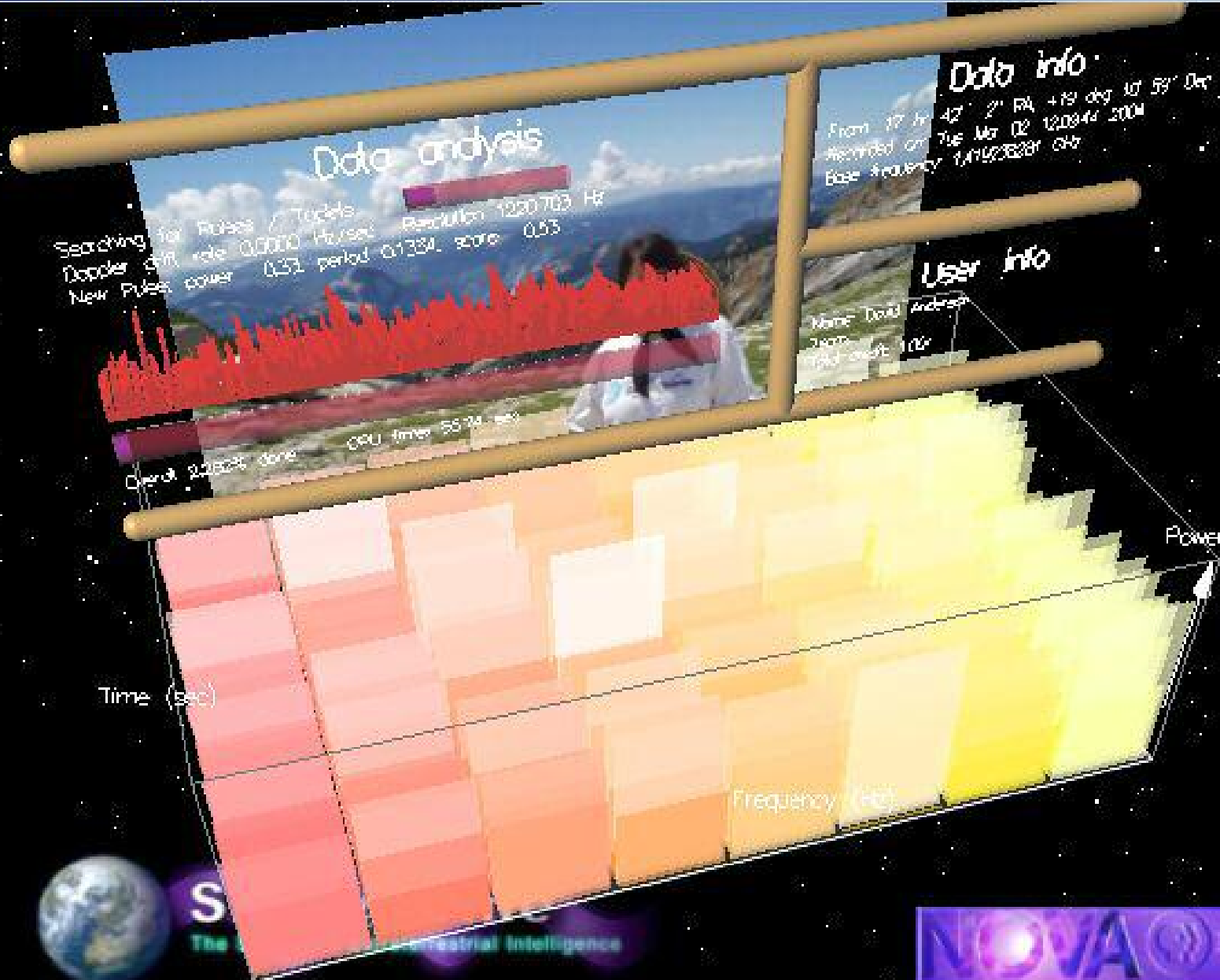

S The Terrestrial Intelligence



climaterprediction.net

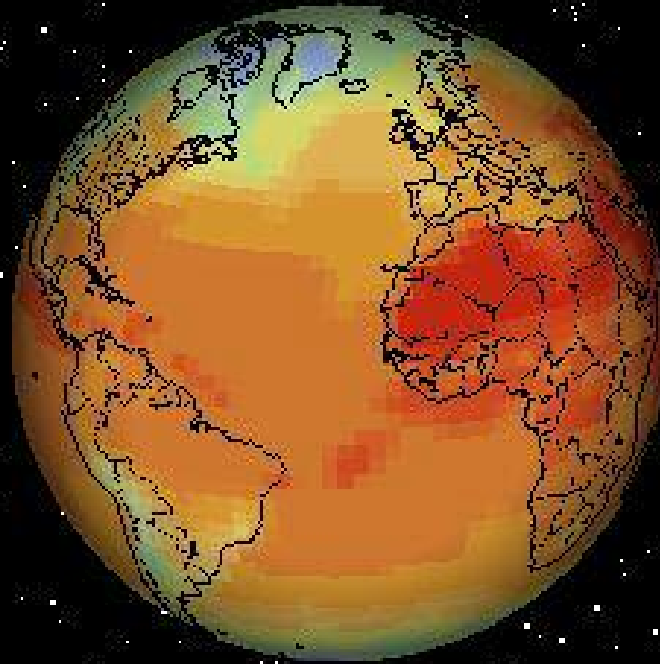

```
hads3  
User : David Anderson; Team : <None>  
Phase : 1 of 3 / Timestep : 25369 of 259248  
Model Date : 19/05/1812 12:30  
Run ID: 259r_100121161, CPU Time: 0025:22:35 (3.60 s/TS)  
T=Temp, P=Precip, R=Pressure, S=SmoothCid, U=GridCid
```

einstein



Einstein@Home

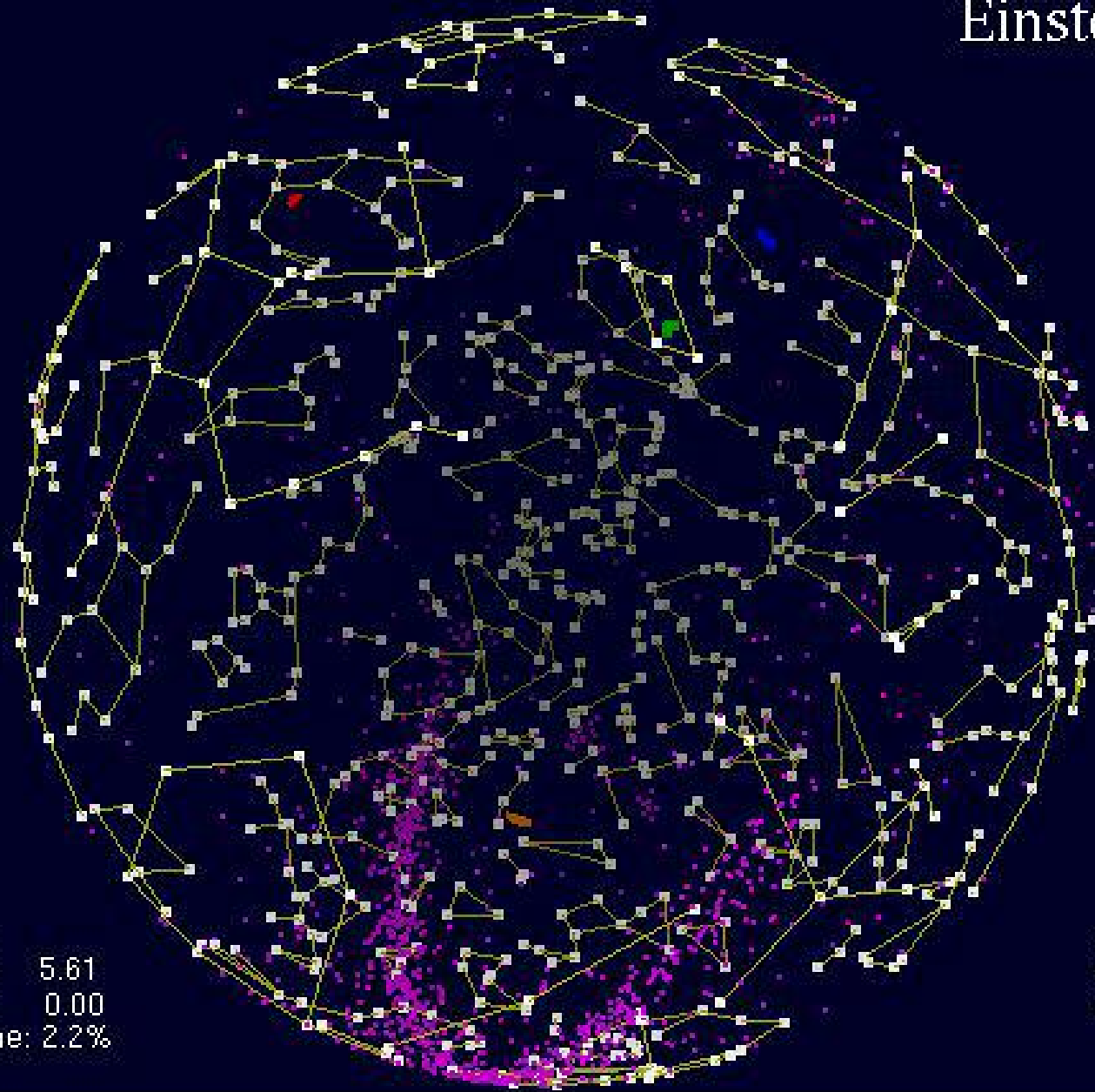

User: davea  
Total Credit: 5.61  
Host Credit: 0.00  
Percent Done: 2.2%

Search Position  
RA: 172.30  
DEC: -83.12



# AstroPulse

- Sky survey
  - Covers decs 0 to 30
  - $\sim 3$  years of data recorded so far.
- Good time resolution
  - Sensitive to  $0.4 \mu\text{s}$  radio pulses at 21 cm
- DM range
  - $-100$  to  $+100 \text{ pc}/\text{cm}^3$
- Sensitivity
  - $10^{-18} \text{ W}/\text{m}^2$  peak (Coherent de-dispersion)



# Search for Optical/Radio Signals from Dyson Sphere Candidates |

Charlie Conroy

- Looked for IR excess from  $>500$  stars
- All stars had age  $> 1$  Gigayear
- 33 stars found with  $12\mu\text{m}$  excess
- Searched for anomalous radio detection using SETI@home and SERENDIP IV databases
- Searched for optical pulse emission using OSETI experiment
- Thus far, none of the 33 sources have shown anomalous optical or radio emission

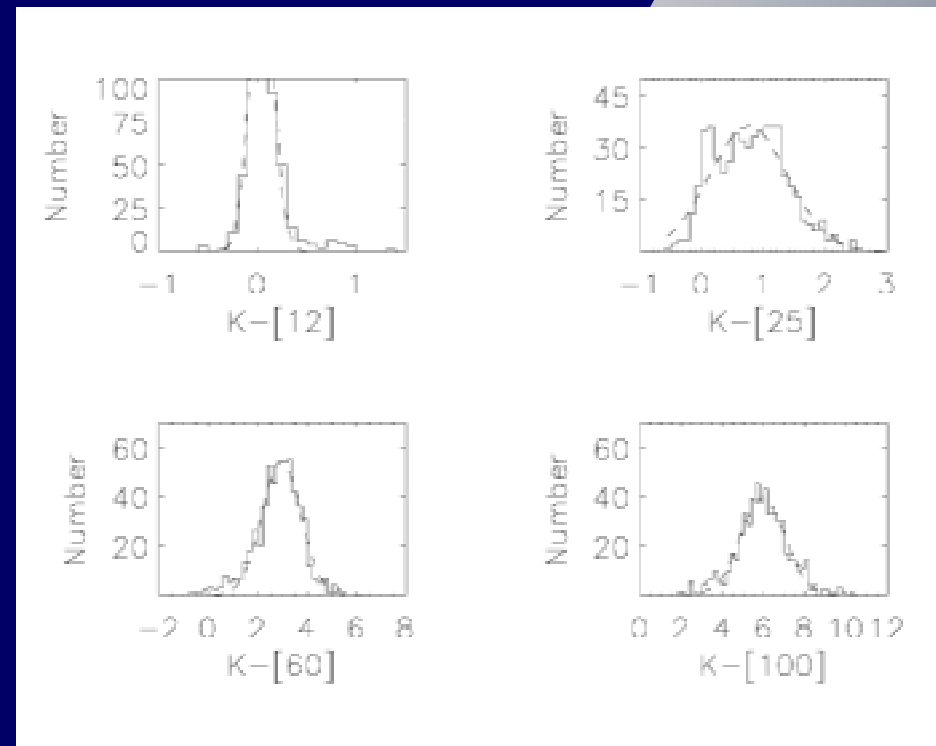

Color excess using 2MASS K band data and 12, 25, 60, & 100 micron IRAS data. An excess at K-[12] is clearly visible and disappears by K-[25]. Dotted lines are Gaussian fits to the distributions. The 33 IR excess candidates have  $K-[12] > 3\sigma$  above the mean.

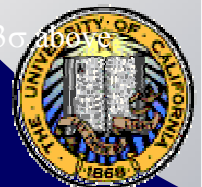

# OPTICAL SETI

1961 Charlie Townes Paper

largely ignored until 1999

1971 Cyclops report calculates radio  $\gg$  optical

Today's lasers can communicate across galaxy



# Optical SETI

- Uses Leuschner Observatory (UCB)
  - Automated 0.8m telescope
- Targeted Search
  - Nearby F,G,K,M stars
  - ~10,000 stars observed so far
  - 100 galaxies



# OSETI Detector

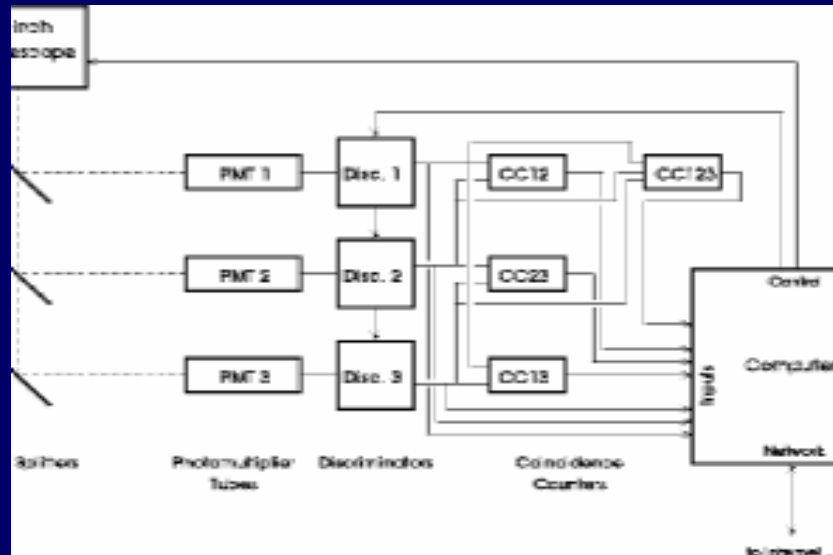

- 3-Photomultiplier fast coincidence detector
  - Sensitive to 1ns pulses
- Low background
  - False alarm rate: 1 per 300 hours ( $10^{-6}$  Hz)
  - Double false alarm rate: 1 per 600 years!
- Good sensitivity
  - $10^{-8}$  W/m<sup>2</sup> peak
  - $10^{-19}$  W/m<sup>2</sup> average



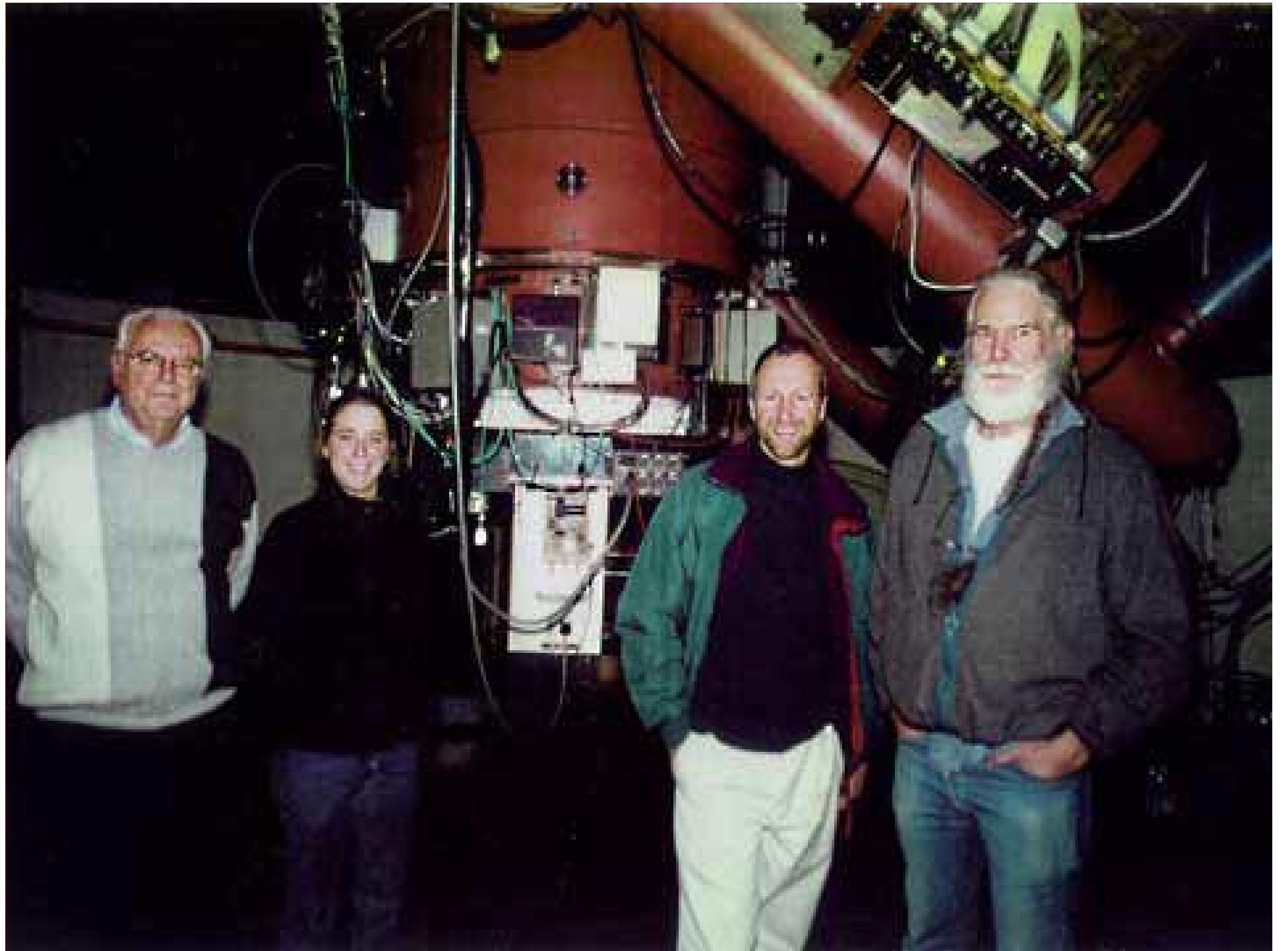

# 10-METER KECK TELESCOPE

Survey: 650 F8 - M5 V, IV

Hipparcos

$V < 8.5$

$B-V > 0.55$  (F8V)

$\text{Sep} > 2$  arcsec

$\text{Age} > 2$  Gyr



# Keck Optical SETI – Data Mining

- Geoff Marcy, Amy Reines
- 650 stars (planet data)
- Echelle Spectrometer
- Can detect 10KW narrow band signal  
(10 KW laser on 10 meter telescope)

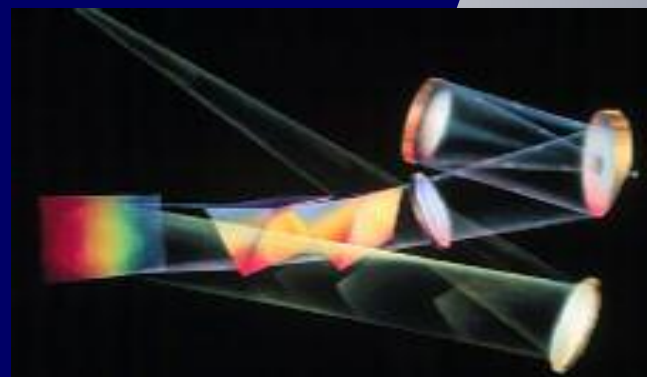

# Amy Reines and Geoff Marcy

## Search for Artificial Emission Lines

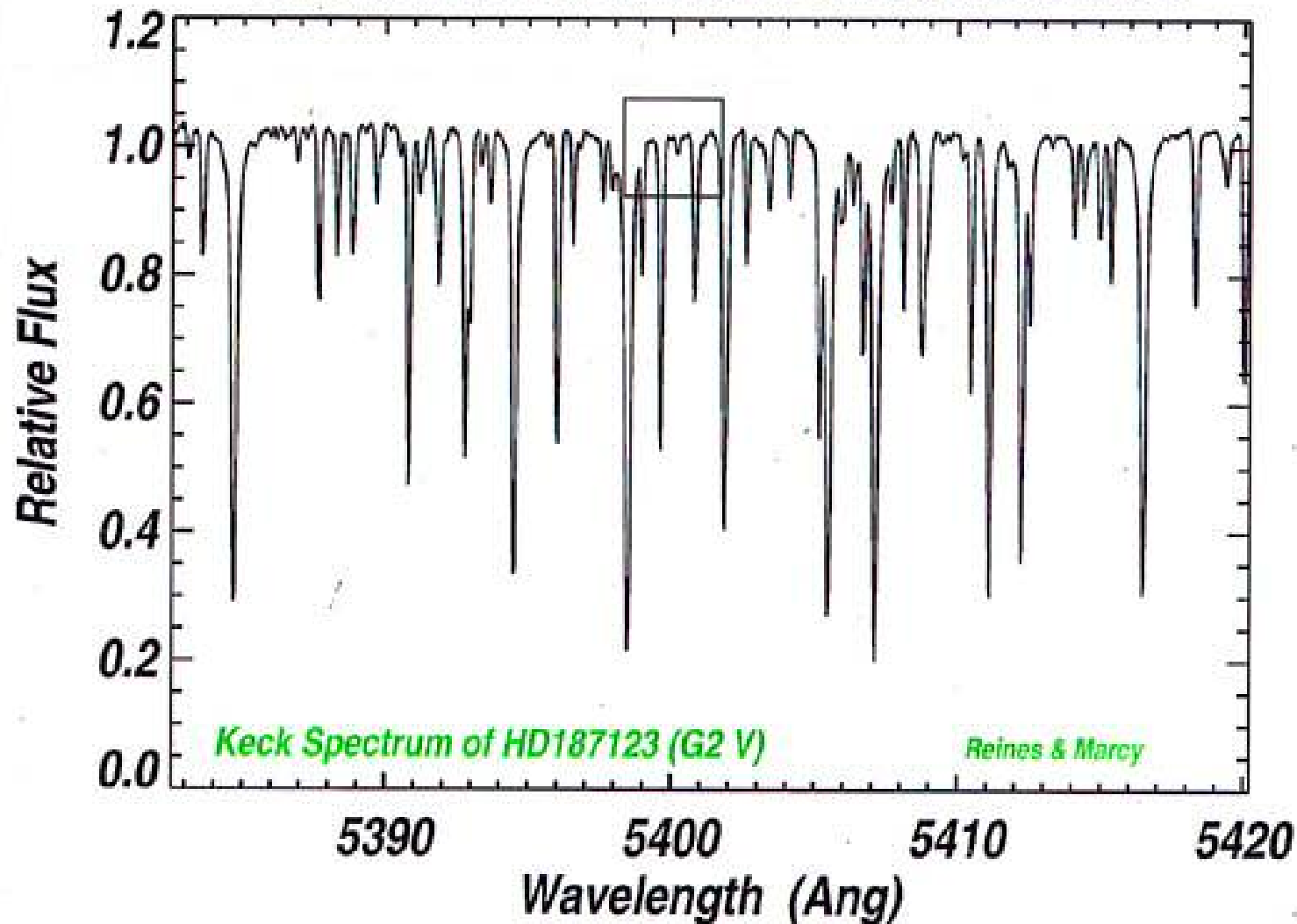

# Allen Telescope Array

- **6.1-meter offset Gregorian (2.4-meter secondary)**
- **rim-supported, hydroformed dishes**





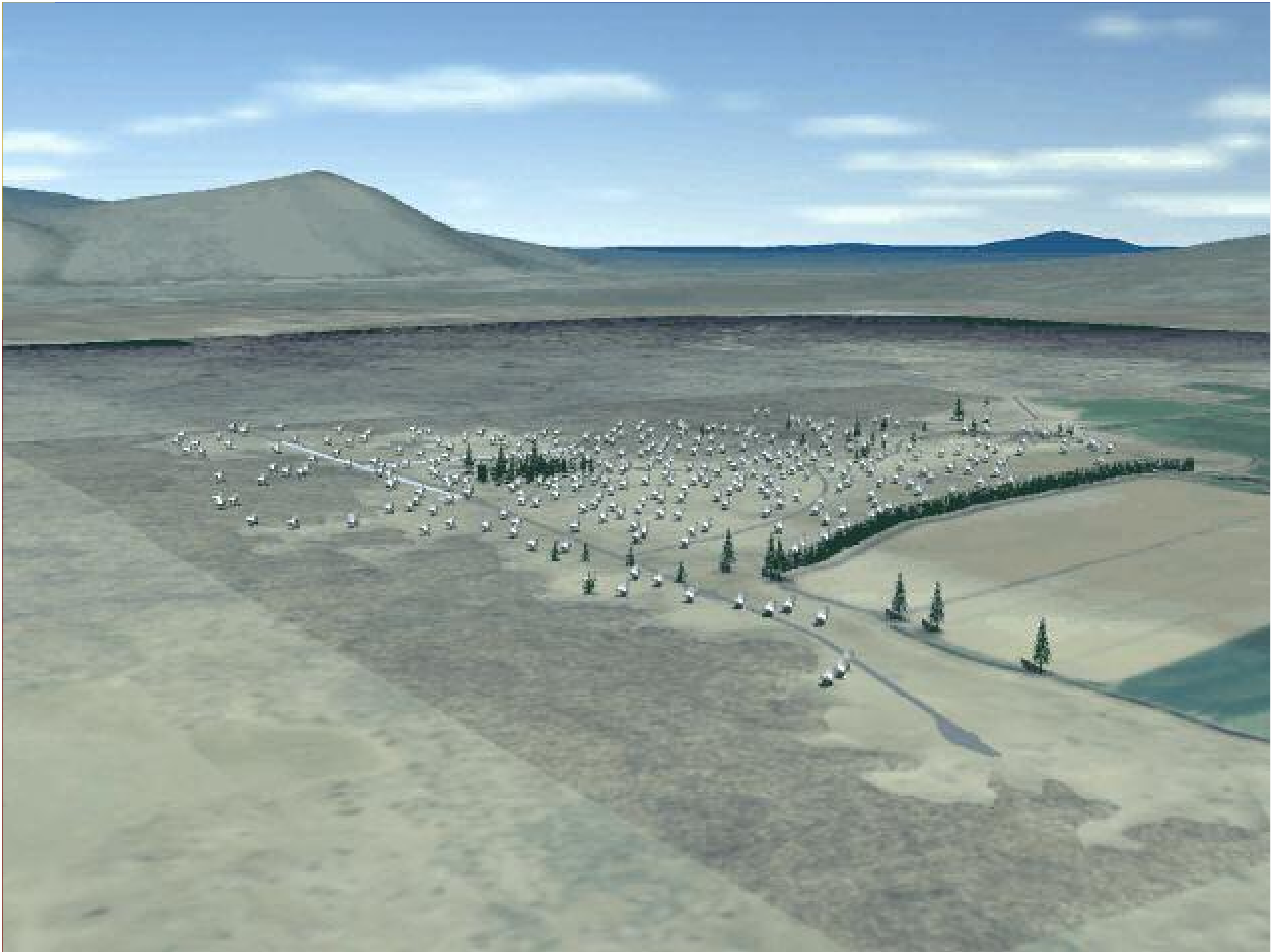

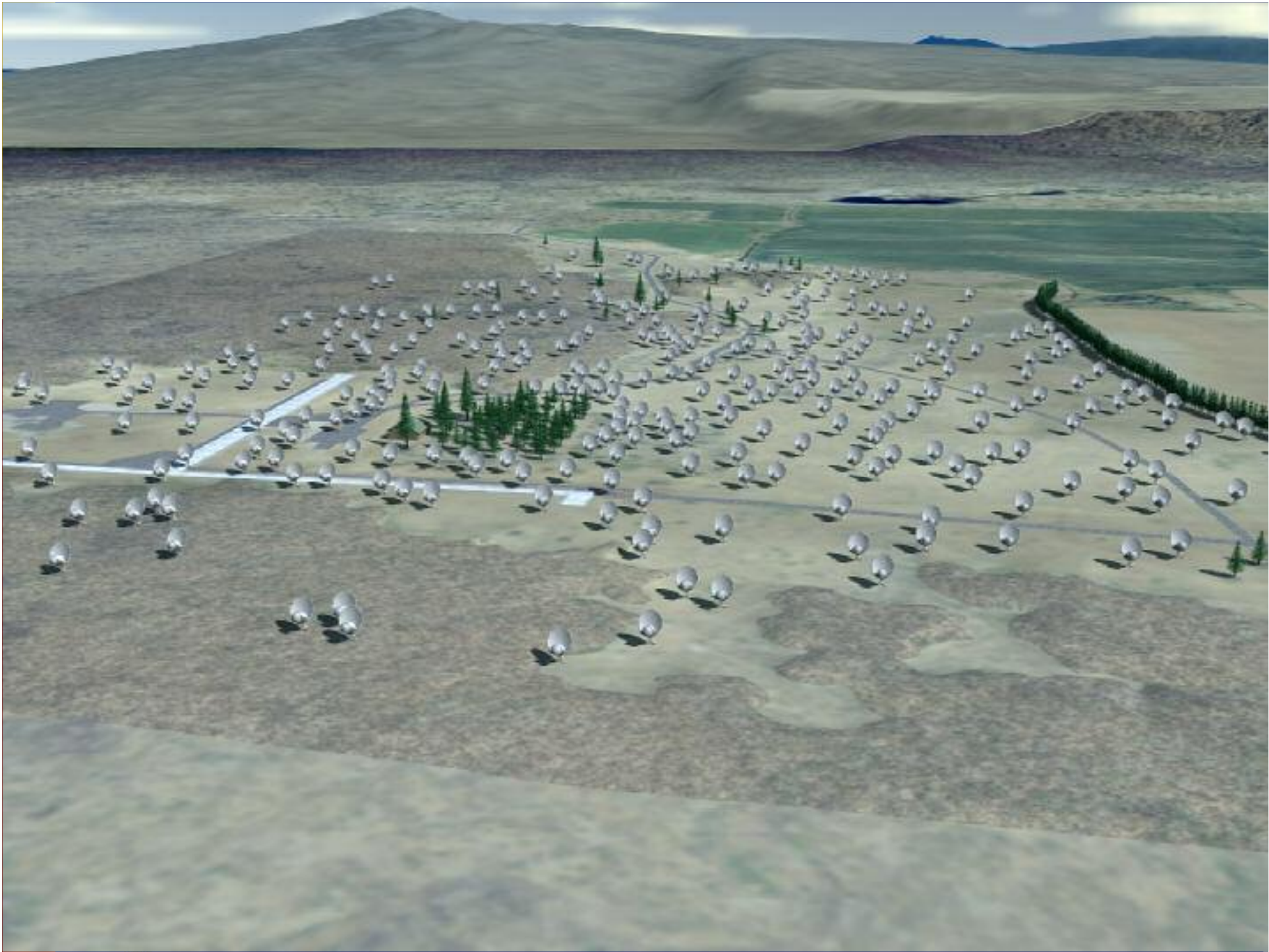



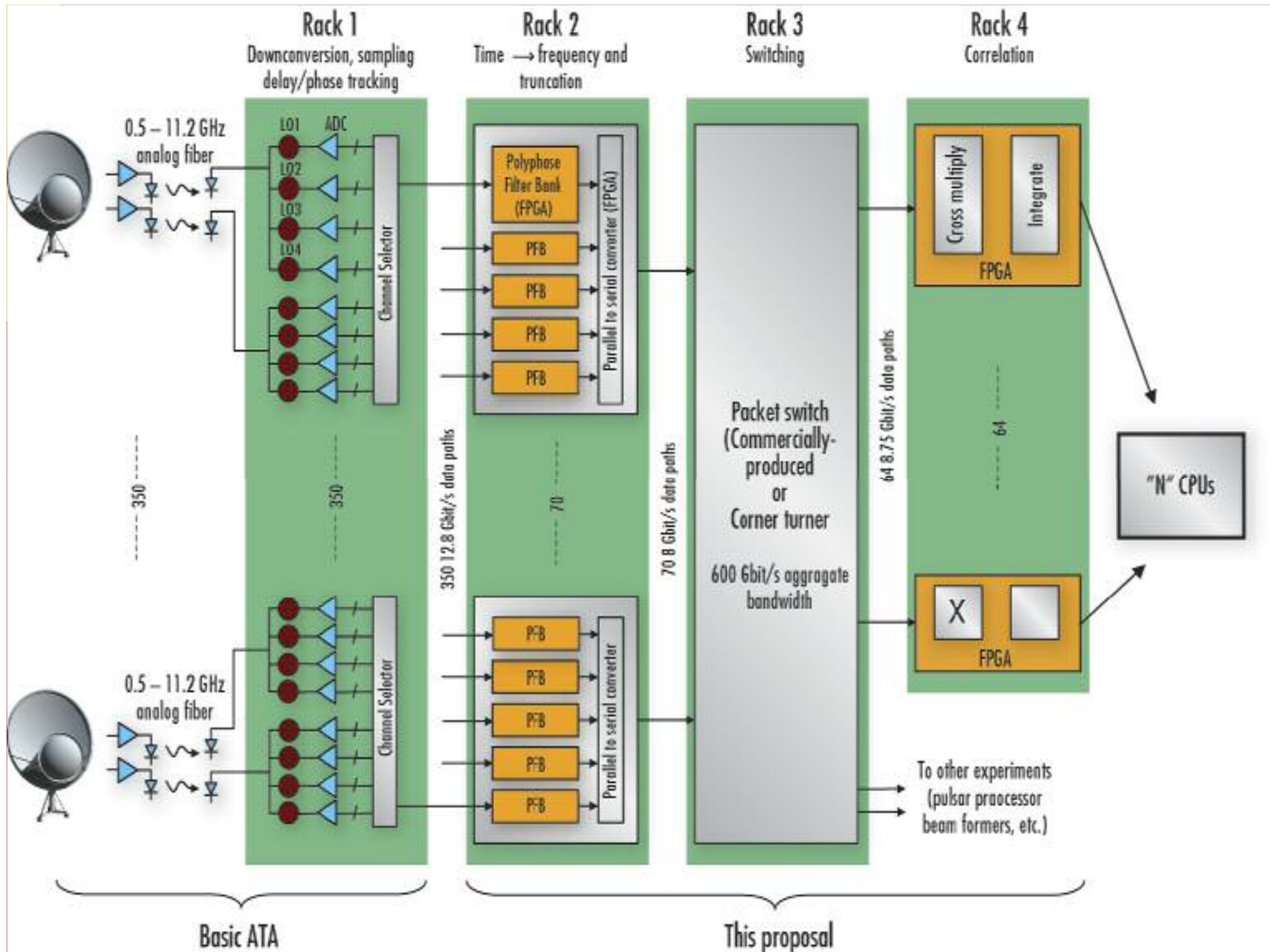

# The Square Kilometer Array

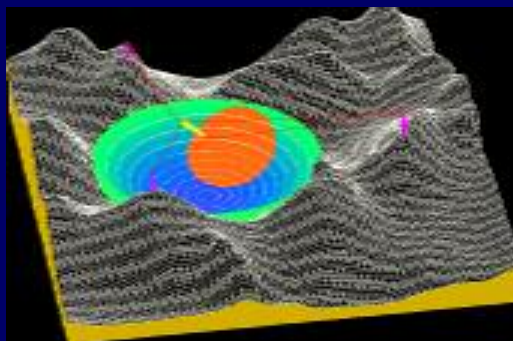
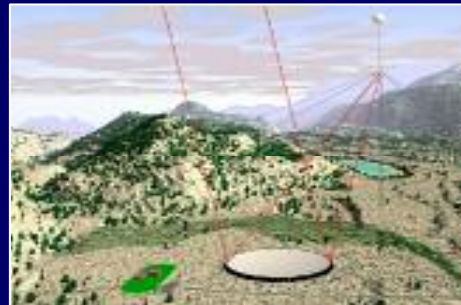
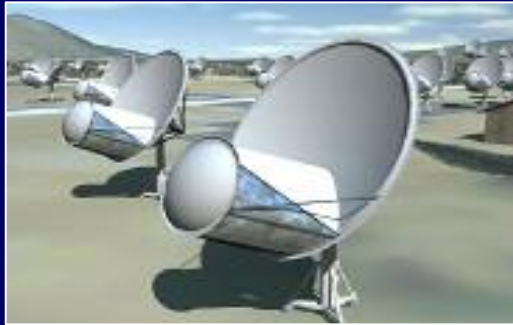

Decision on site ~ 2006  
concept ~ 2008



# Generalized Approach to Radio Astronomy Signal Processing



# Multi-Purpose FPGA-Based Spectrometer – Low Bandwidth

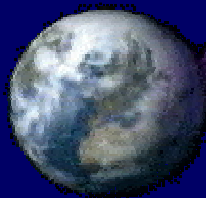
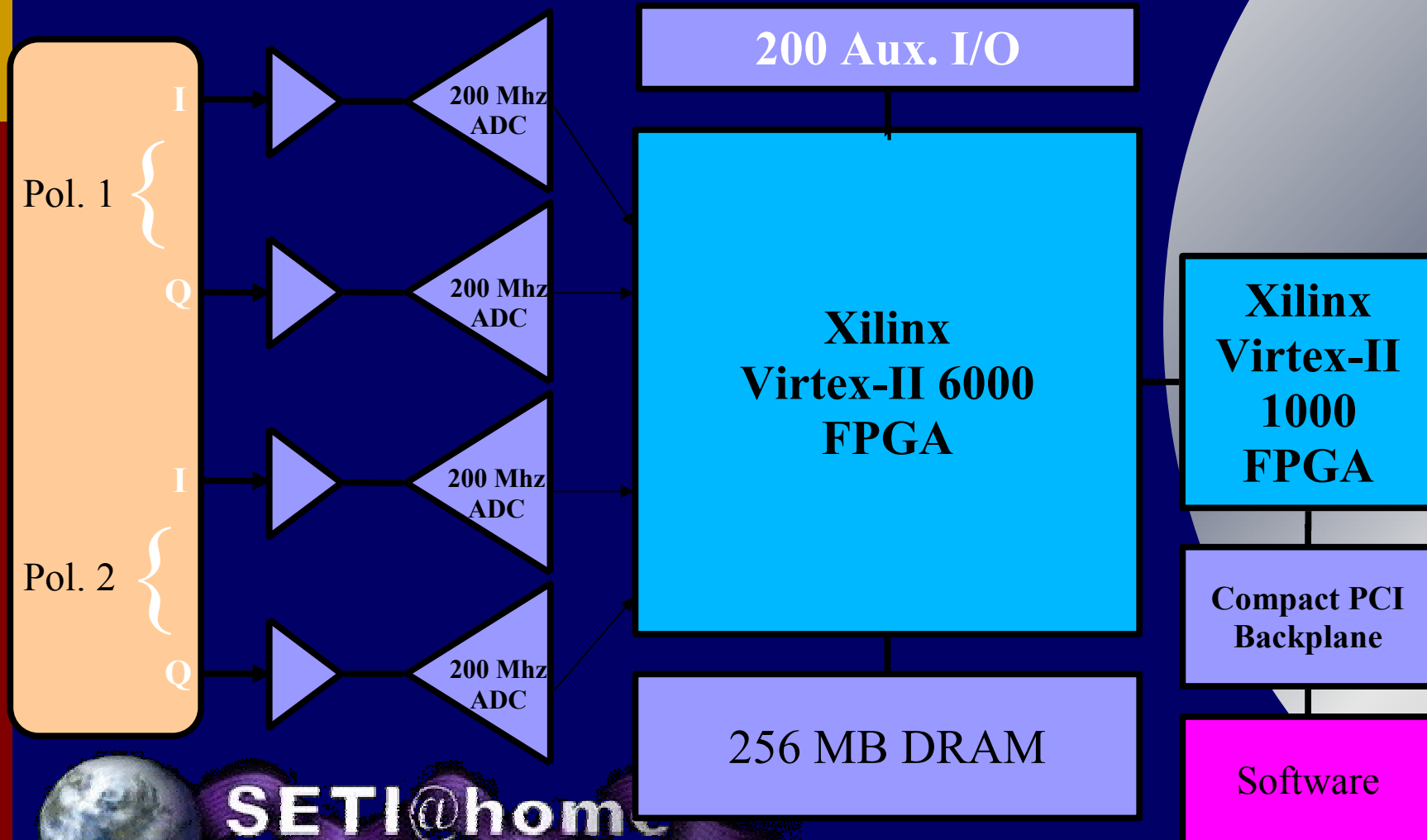

**SETI@home**  
The Search for Extraterrestrial Intelligence

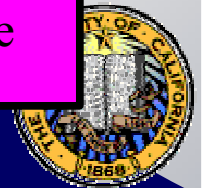



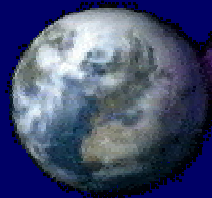

**SET**  
The Search



# GALFA Spectrometer



## SETI Applications

- JPL/UCB/SI DSN Sky Survey (20 GHz Bandwidth)
- Parkes Southern SERENDIP
- ALFA Sky Survey (300 MHz x 7 beams)
- SETI Italia (Bologna)
- SETI@home

## Astronomy Applications

- GALFA Spectrometer – Arecibo Multibeam Hydrogen Survey
- Astronomy Signal Processor – ASP – Don Backer, Ingrid Stairs, (pulsars)
- ATA4 Correlator F Engine
- Reionization Experiments (Backer (UCB), Chippendale/Ekers (ATNF))
- Antenna Holography, ATNF, China





# SERENDIP V Spectrometer

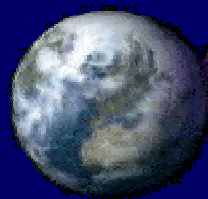
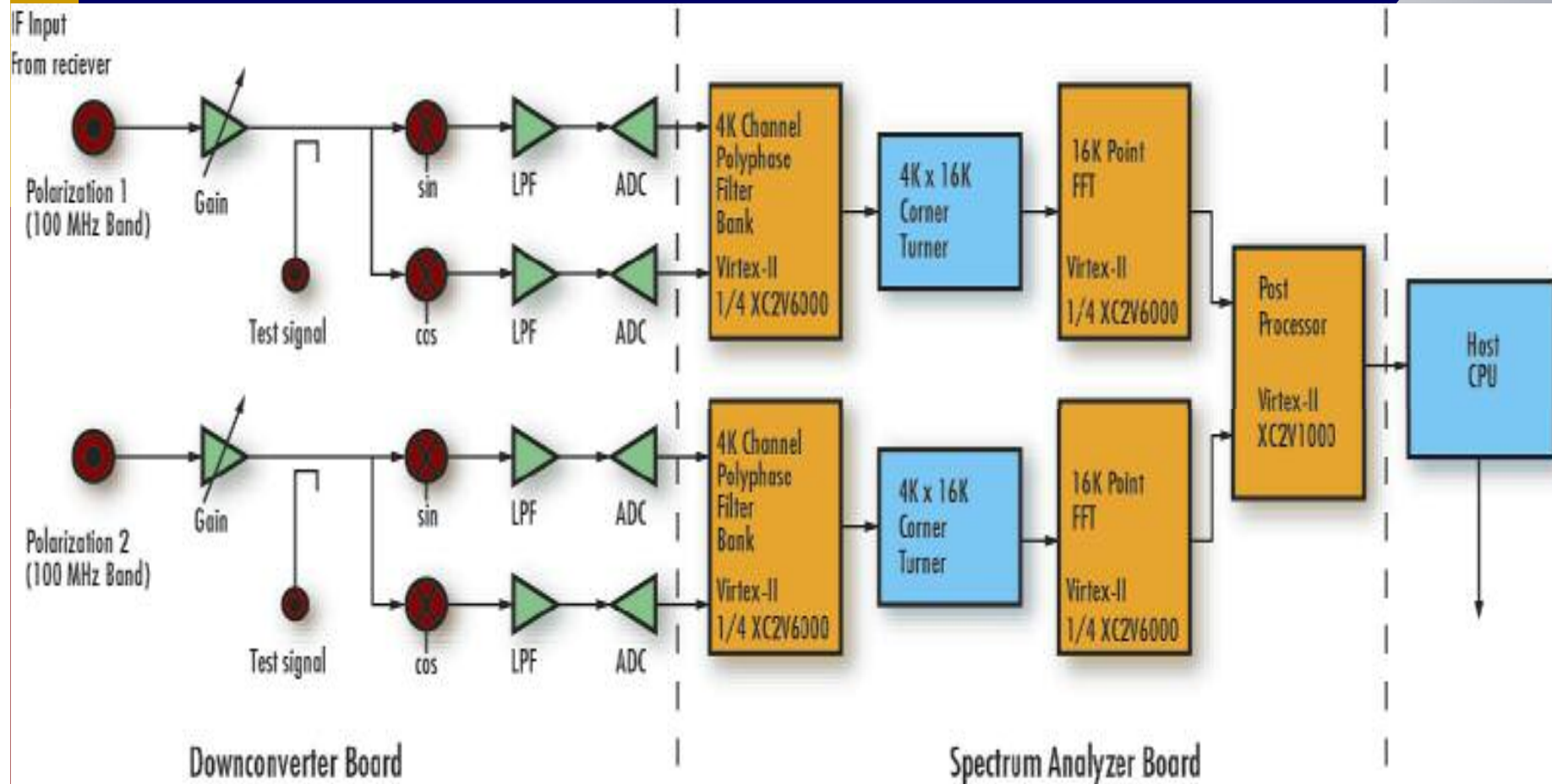

**SETI@home**

The Search for Extraterrestrial Intelligence



# GALFA Spectrometer

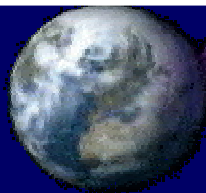
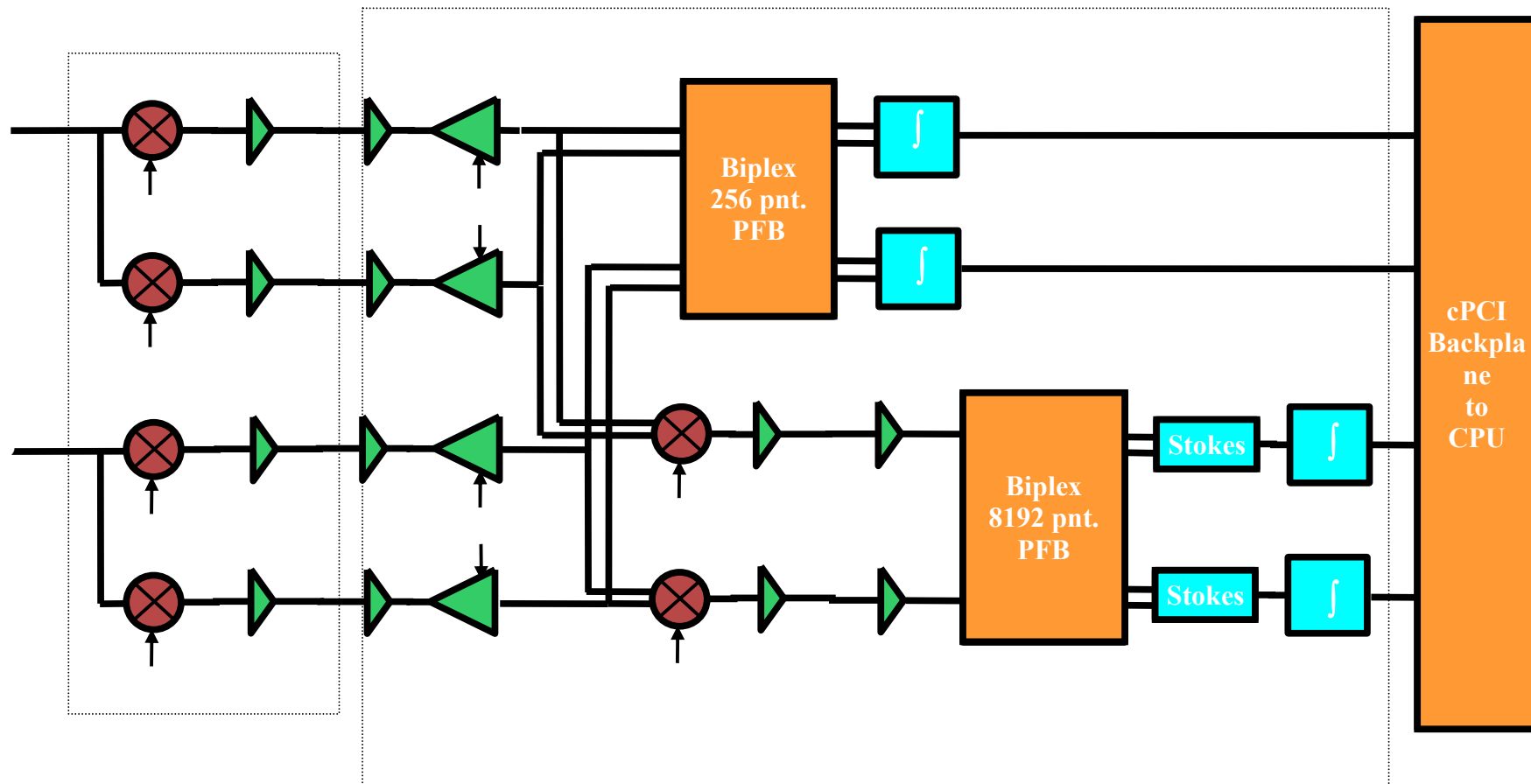

SETI@home

The Search for Extraterrestrial Intelligence



# Astronomy Signal Processor – Don Backer

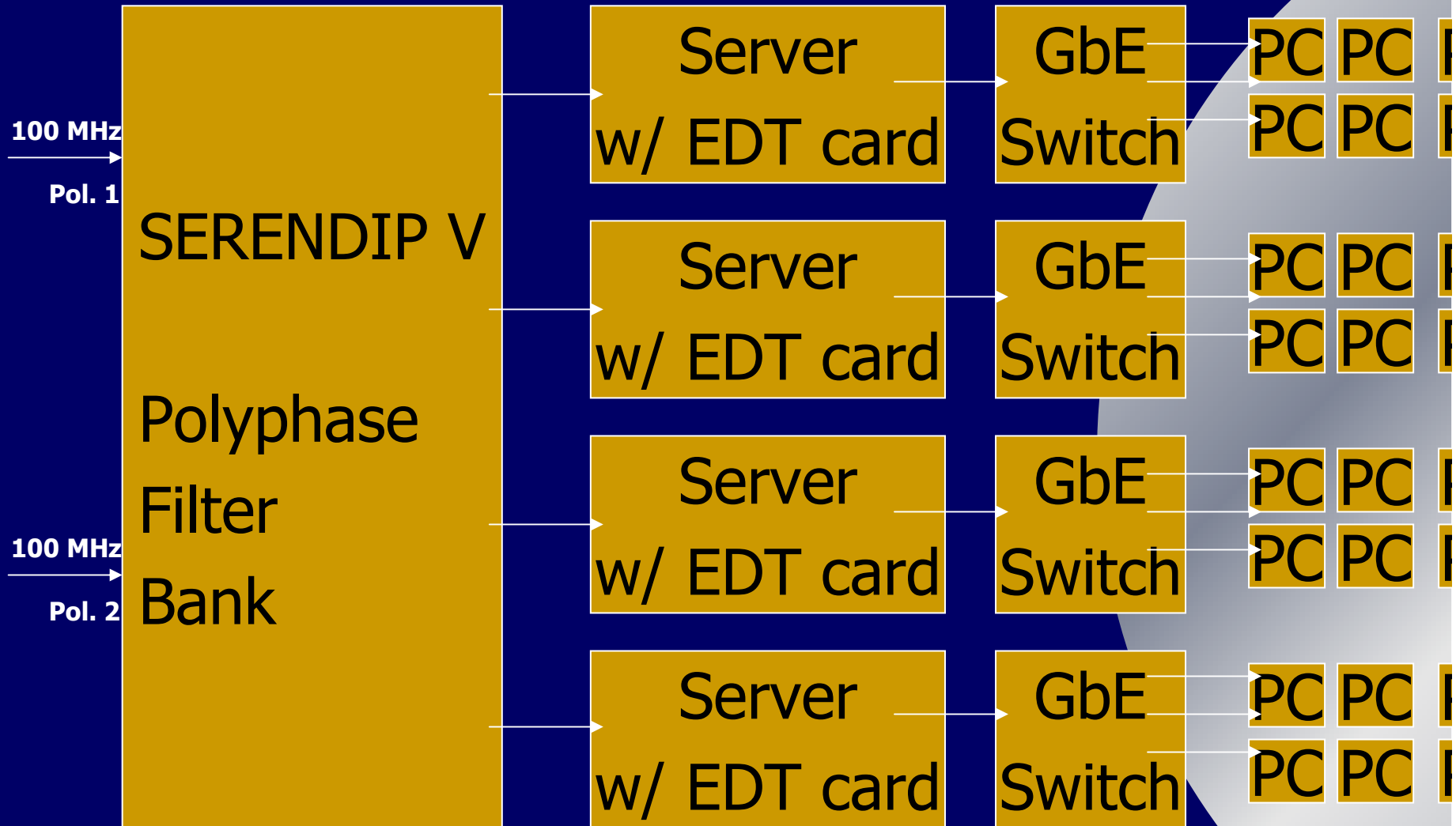

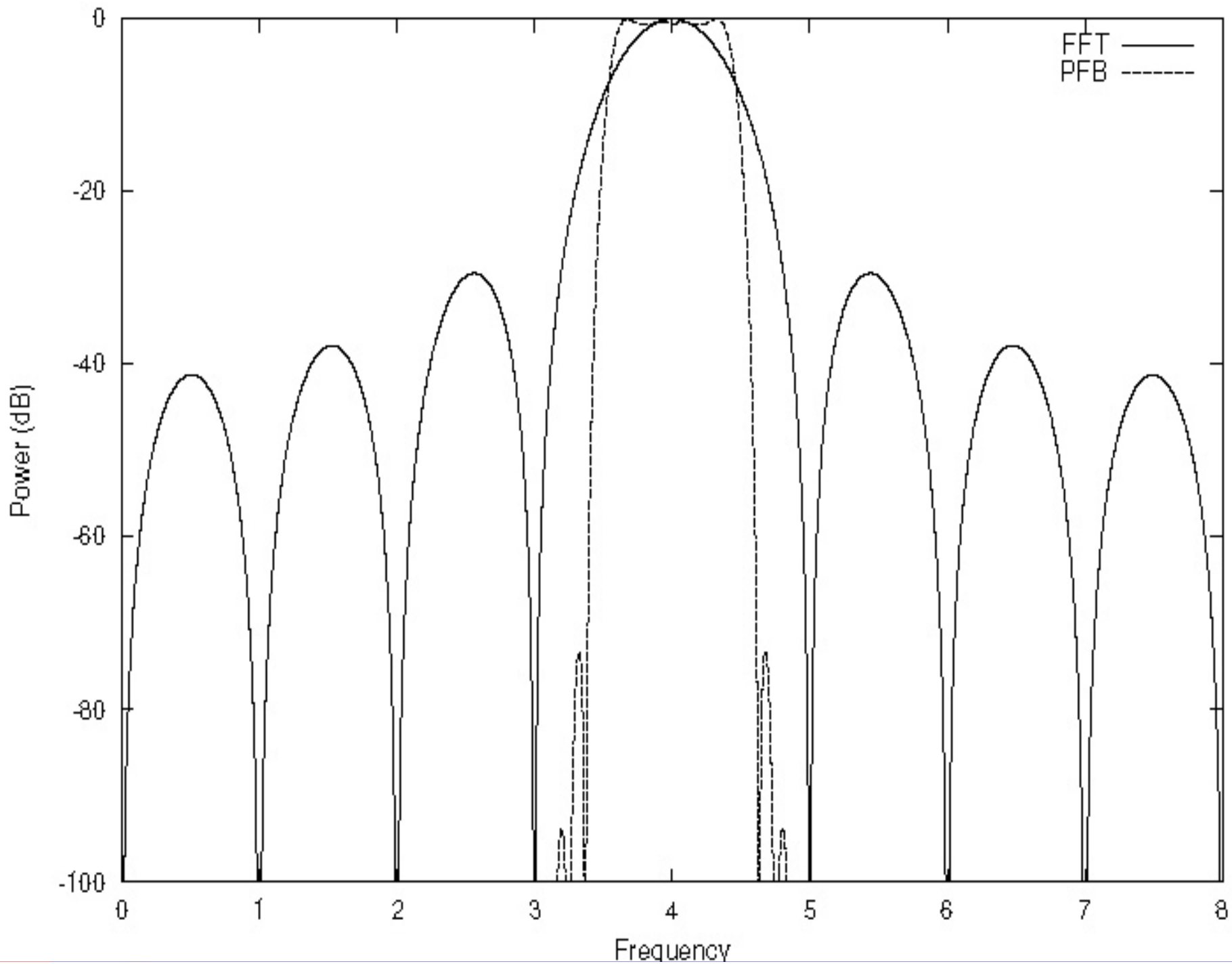

# PFB vs. FFT

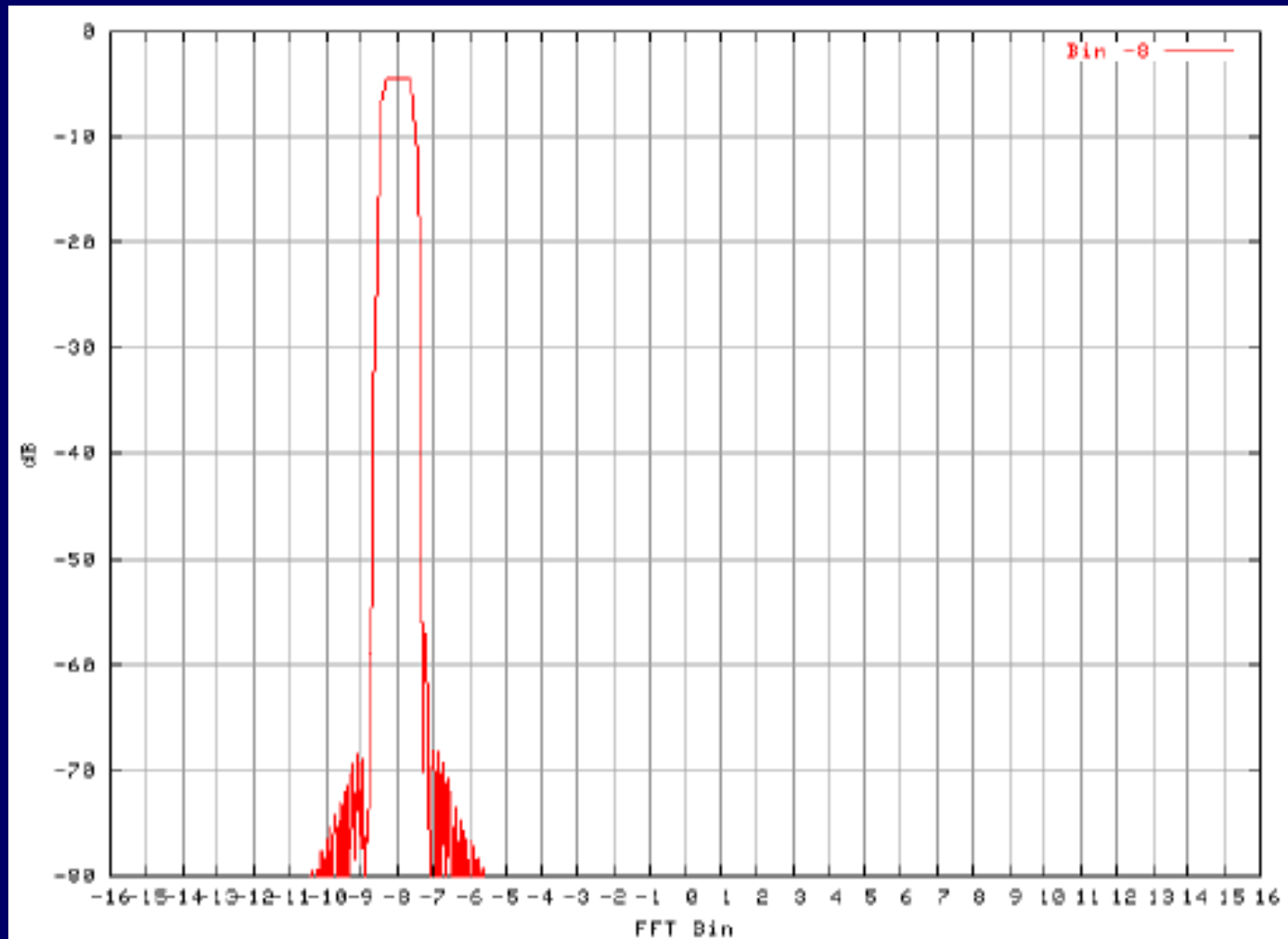

# PFB vs. FFT

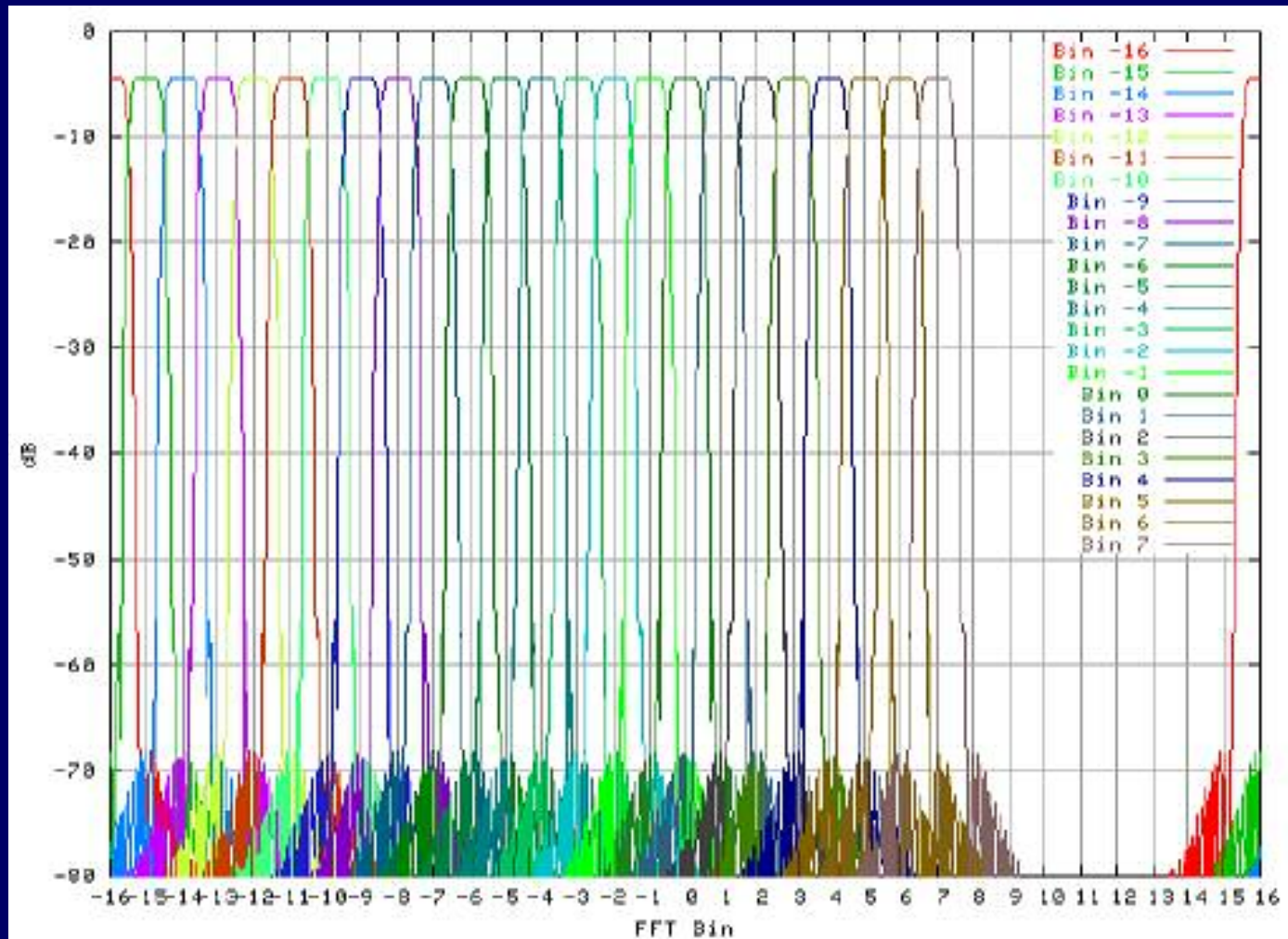

# Biplex Pipelined FFT

## Example: 8 pnt. FFT

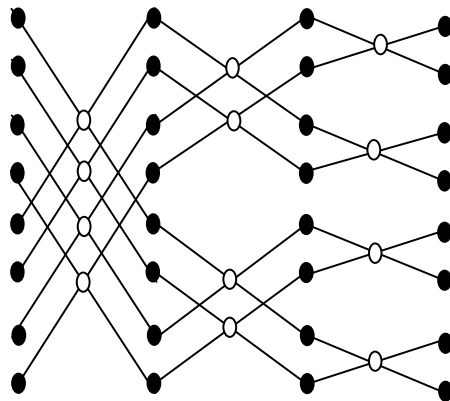
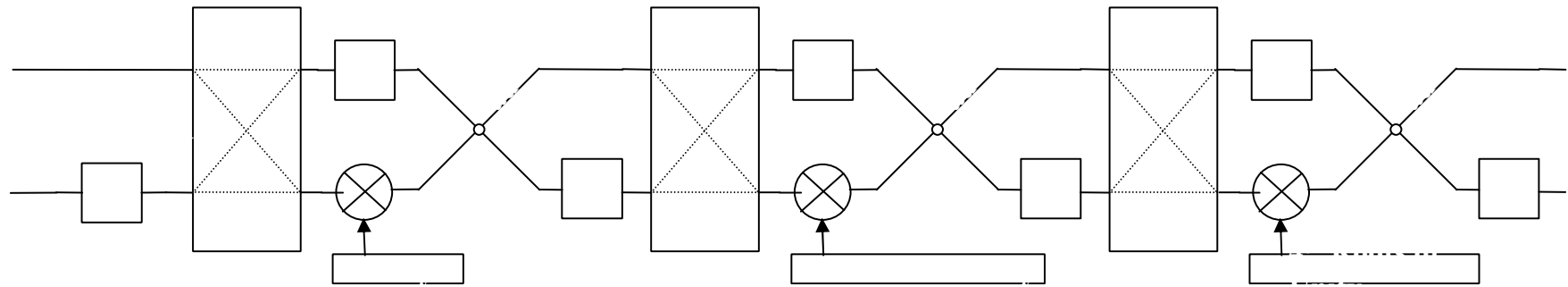

# JFFT FFT controls

- Any length transform
- Input width and output width
- twiddle coefficient width
- 3 or 4 multiplier complex multiply
- Specify downshift or programmable downshift (optional rounding)
- Decimate FFT option
- Blockram / CLB memory threshold option
- Overflow detection





# JFFT additional PFB controls

- Filter overlap
- Width of filter coefficients
- Window function for filter (hamming, hann, etc.)
- Import filter coefficients for custom filter performance



# GHz bandwidth spectrometer

- Dual 1 Gsample/sec 8 bit ADC chip  
0.5 to 1 GHz bandwidth
- Can be used as single 2 Gsample/sec ADC  
1 to 2 GHz bandwidth

ATMEL, National Semiconductor ADC's

2 watts



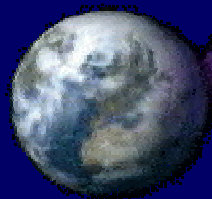
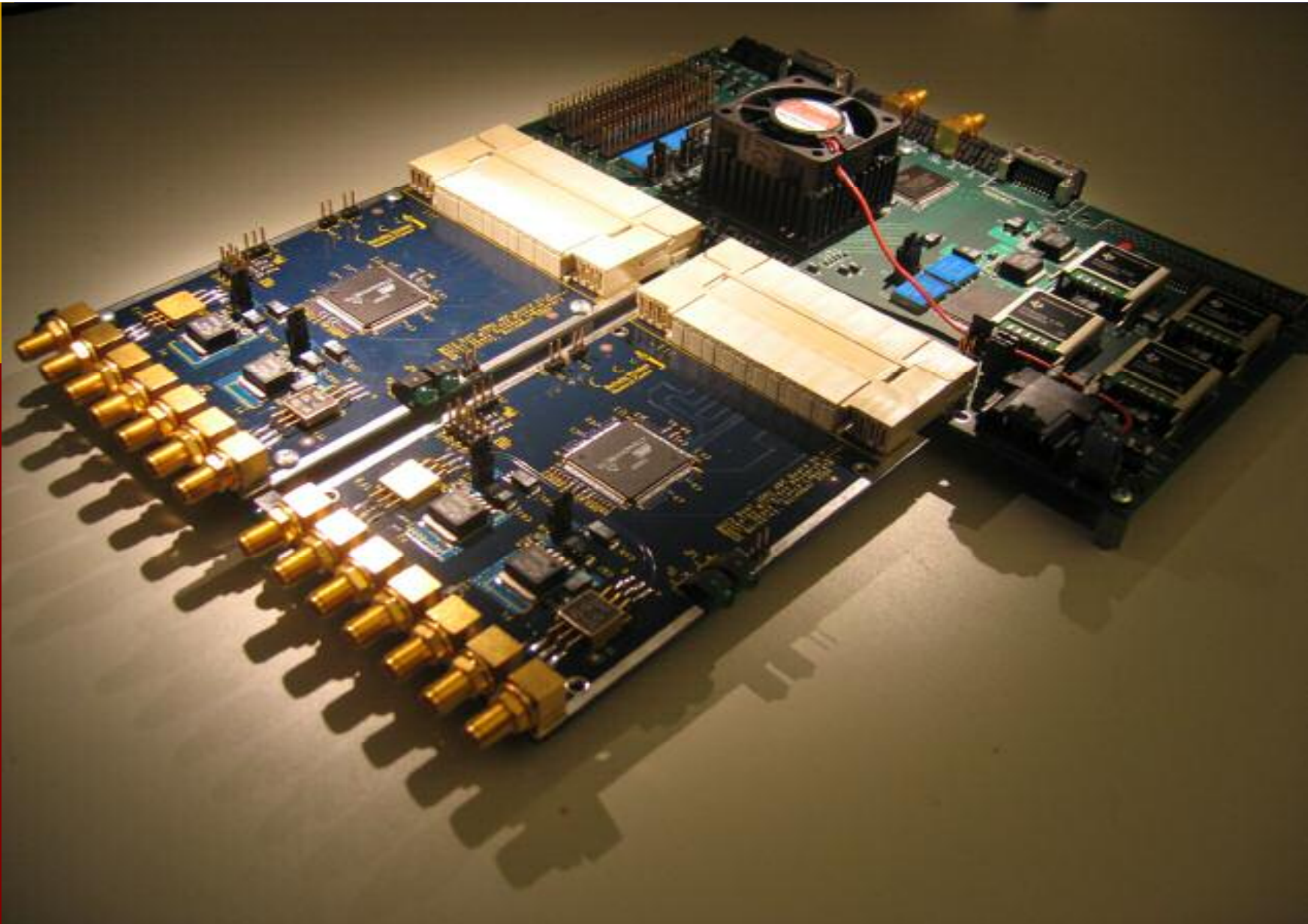

**SETI@home**

The Search for Extraterrestrial Intelligence



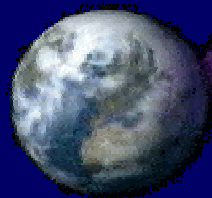
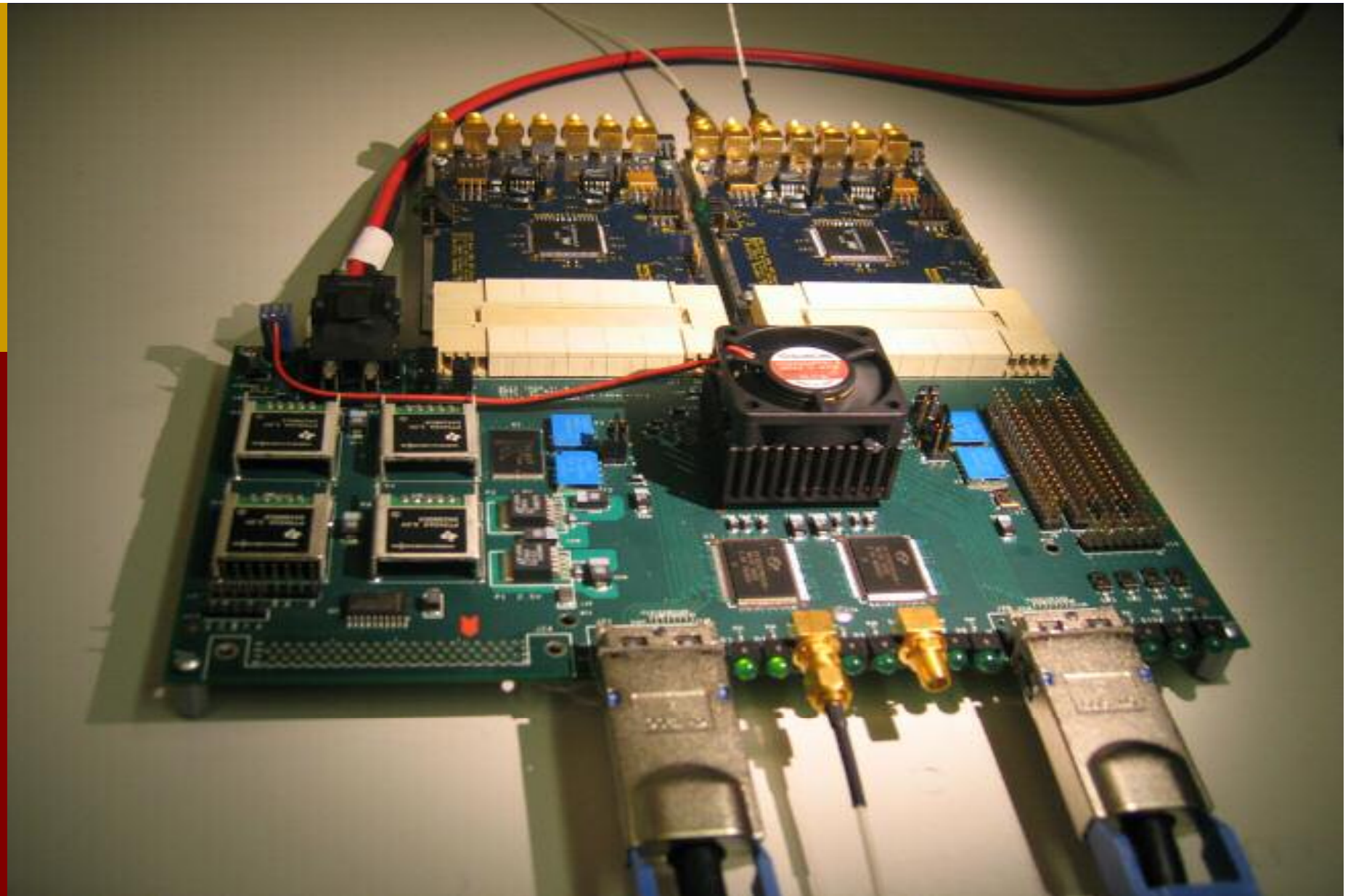

**SETI@home**

The Search for Extraterrestrial Intelligence



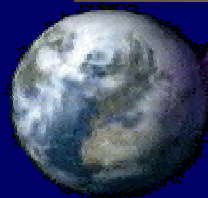
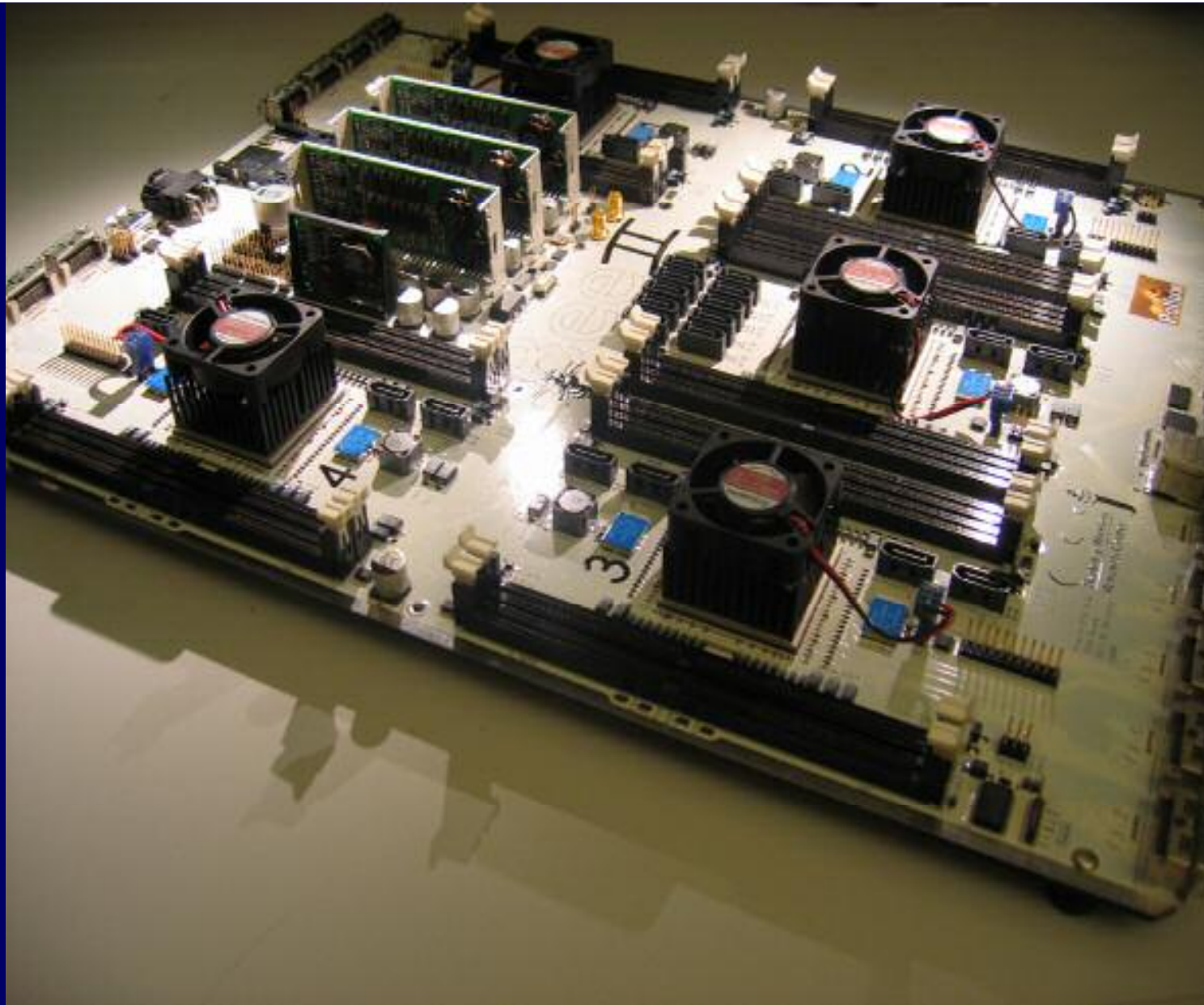

**SETI@home**

The Search for Extraterrestrial Intelligence



# Compute Module Diagram

4GB DDR2 DRAM  
12.8GB/s (400DDR)

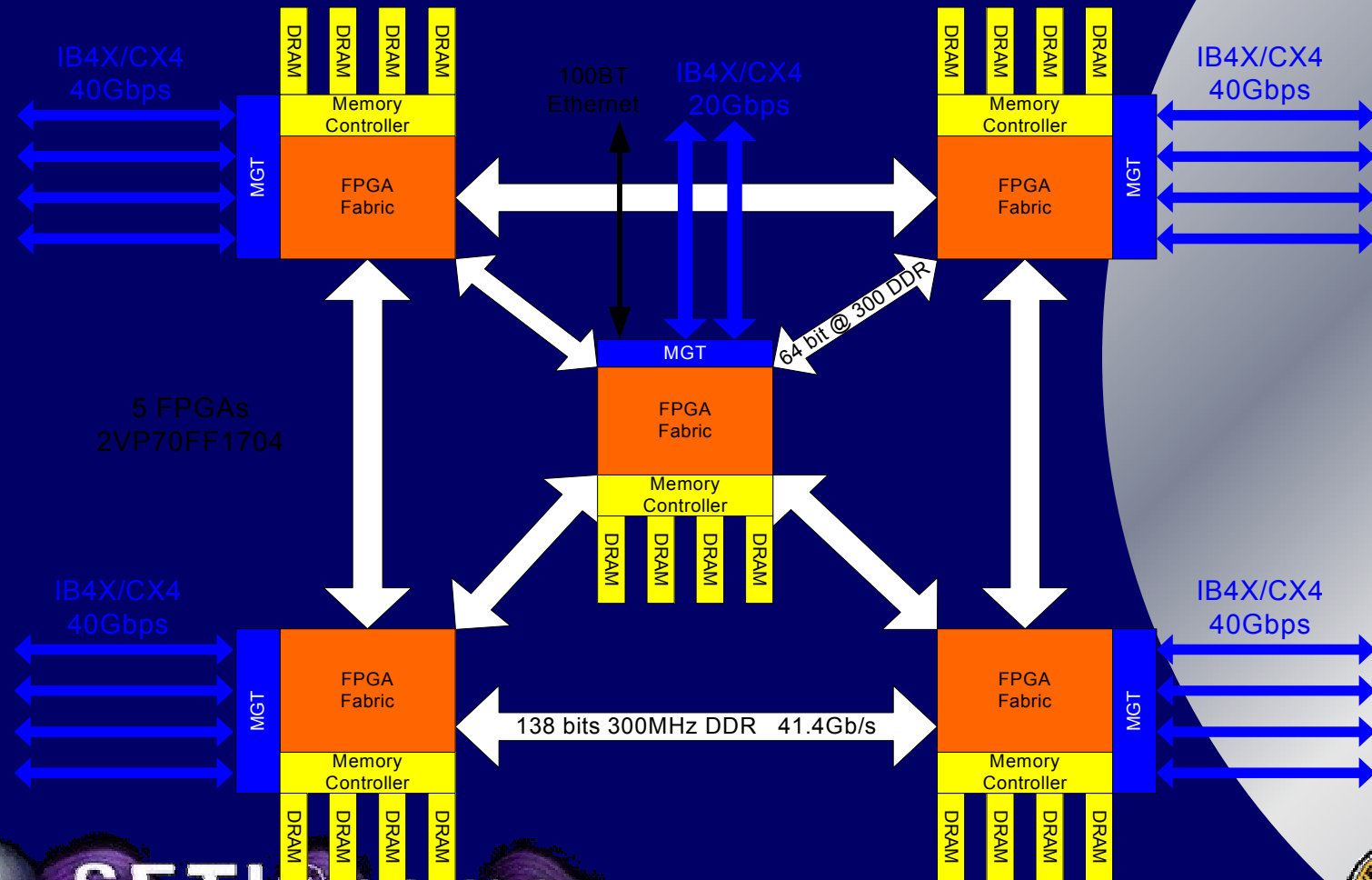

5 FPGAs  
2VP70FF1704



# 19" 48RU Rack Cabin Capacity

- 40 compute nodes in 5 chassis (8U) per rack
- Up to 16 trillion CMac/s performance per rack
- 250 Watt AC/DC power supply to each blade
- 12.5 Kwatt total power consumption
- Hardware cost: ~ \$1M



# Global Interconnects

- Commercial Infiniband switch from Mellanox, Voltaire, etc.
  - Packet switched, non-blocking
  - 24 ~ 144 ports (4X) per chassis
  - Up to 10,000 ports in a system
  - 200~1000 ns switch latency
  - 400~1200 ns FPGA to FPGA latency
  - 480Gbps ~ 2.88Tbps full duplex constant cross section bandwidth
  - <\$400 per port

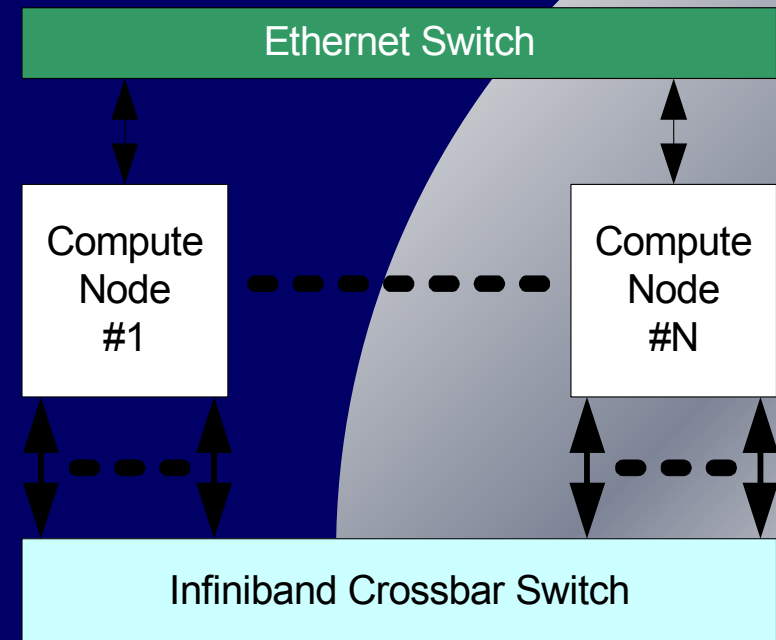



# Unified Digital Processing Architecture

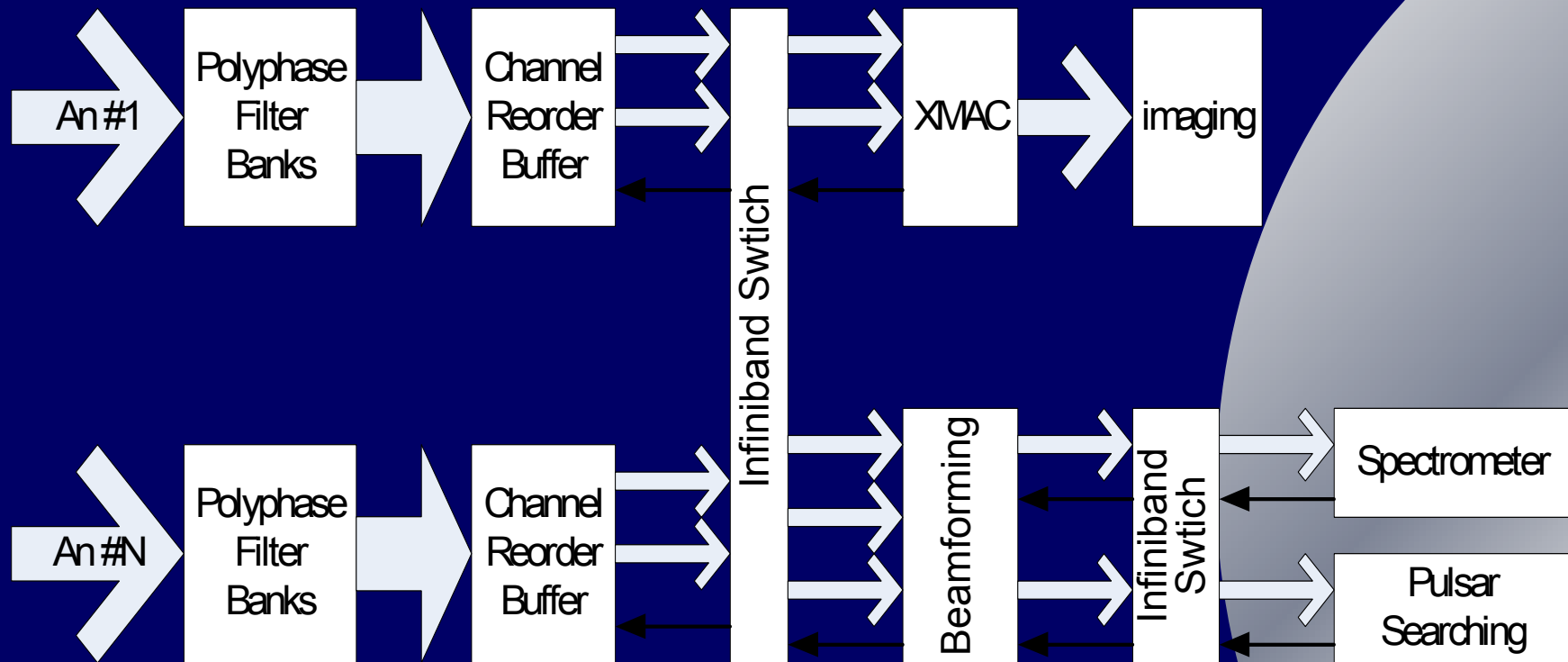

- Distributed per antenna spectral channel processing
- Multiple reconfigurable backend application processing
- Commercial packet switched interconnect
- Backend data pulling through remote DMA access



# Applications

- VLBI Mark 5B data recorder - Haystack – 500 MHz  
VLBA and Beamforming - CfA, Bob Wilson, Jonathan Weintroub
- SETI – Arecibo (UCB)  
ATA (Seti Institute)  
JPL/UCB/SI DSN 20 GHz dual pol (Preston, Gulkis, Levin, Jones)
- Correlators and Imagers:  
ATA (Mel Wright)  
Reionization Experiment (Backer/NRAO)  
Carma Next Gen (Dave Hawkins, Caltech)  
SKA demonstrator South Africa (Justin Jonas)  
MWAR, LWA – MIT, NRL



# Moore's Law in FPGA world

Computational Density Comparison

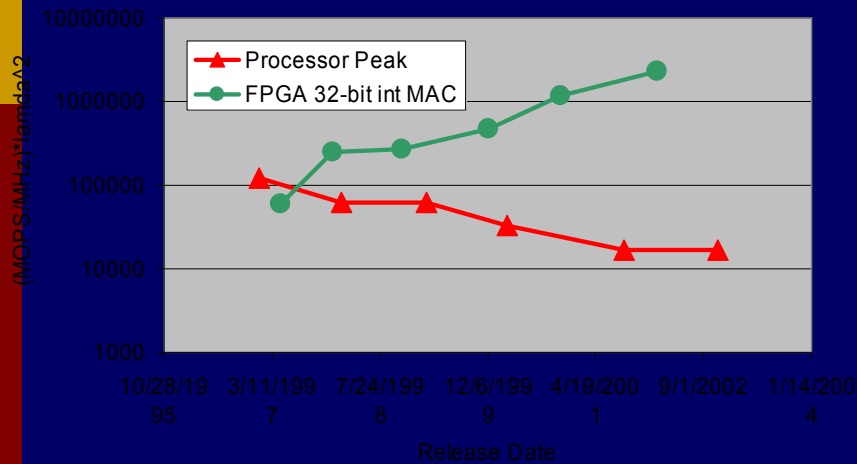

**100X More efficient than micro-processors!**

**3X improvement per year!**

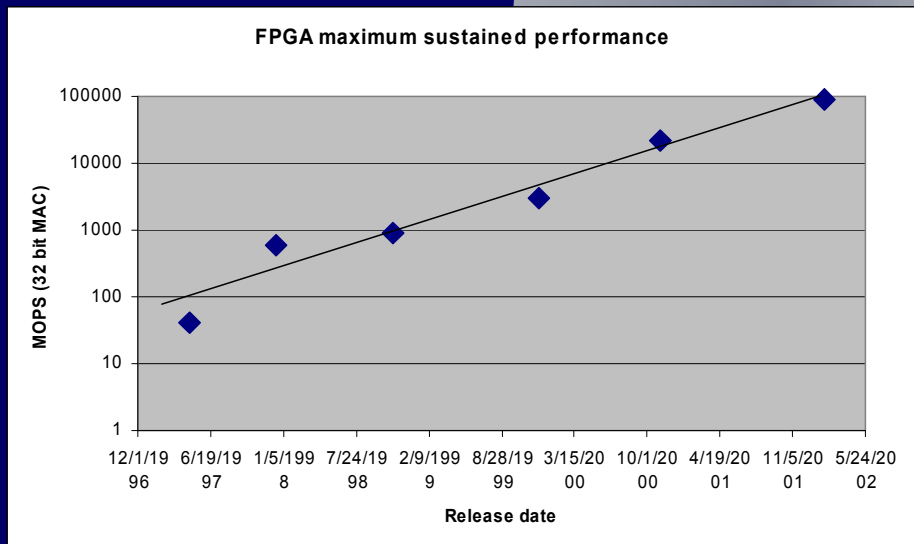

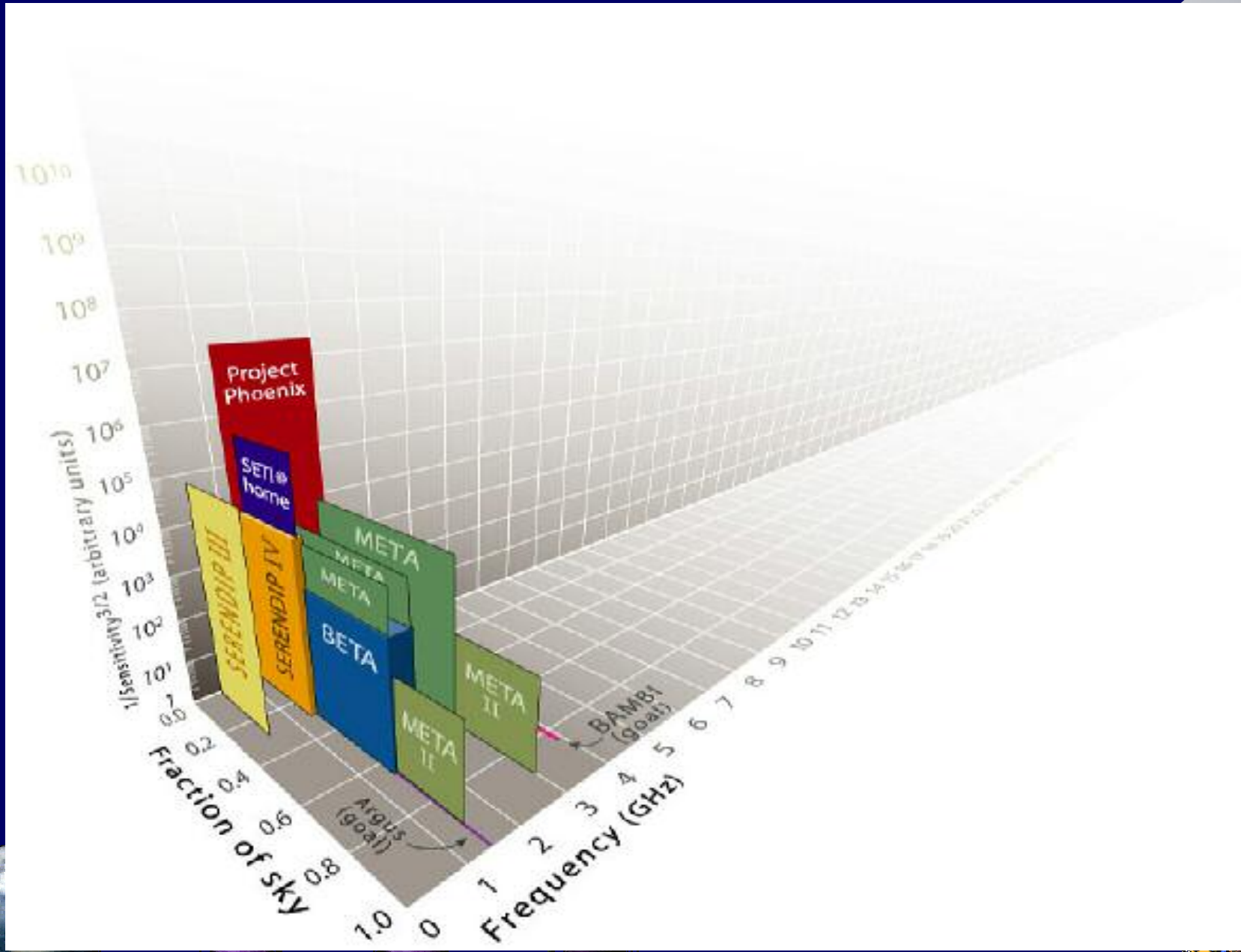

# SERENDIP Progress

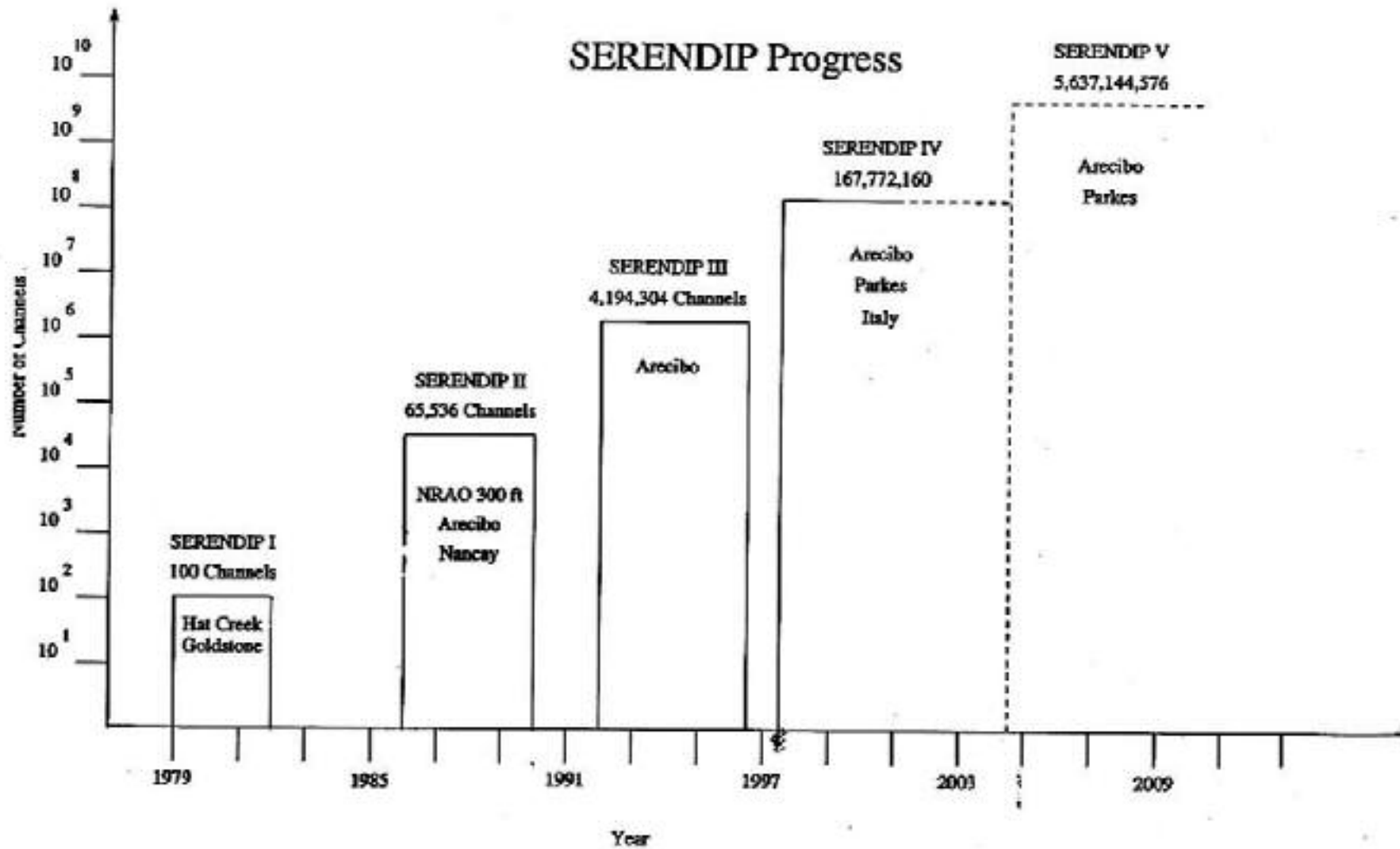

# Future SETI Spectrometers

2015	4 THz	400 beams 10 GHz each
2020	128 THz	12,800 beams
2025	4000 THz	40,000 beams
2030	128,000 THz	1M beams



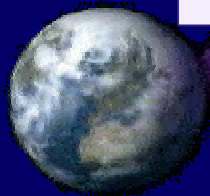
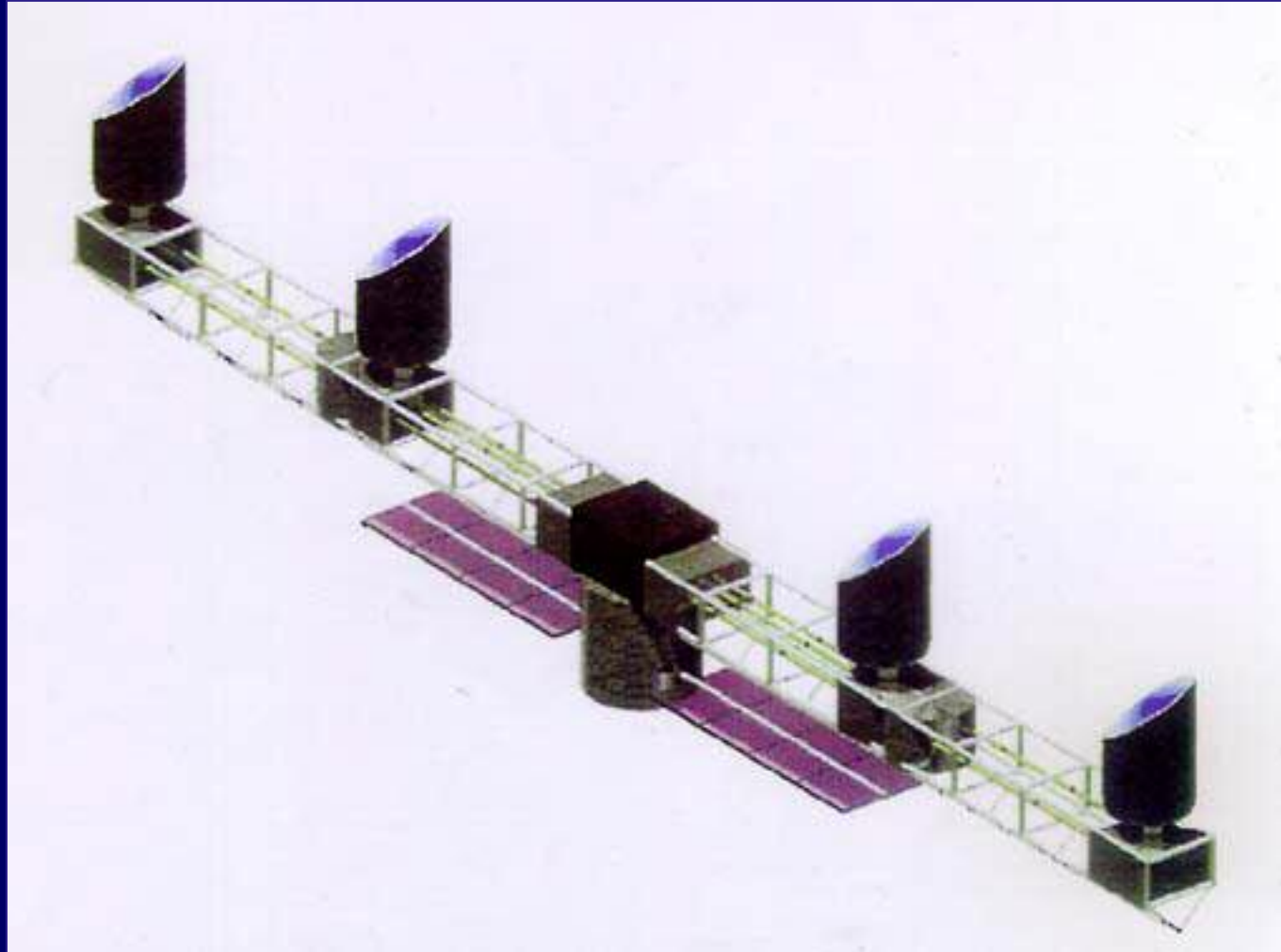

**SETI@home**

The Search for Extraterrestrial Intelligence



# HISTORY of SETI

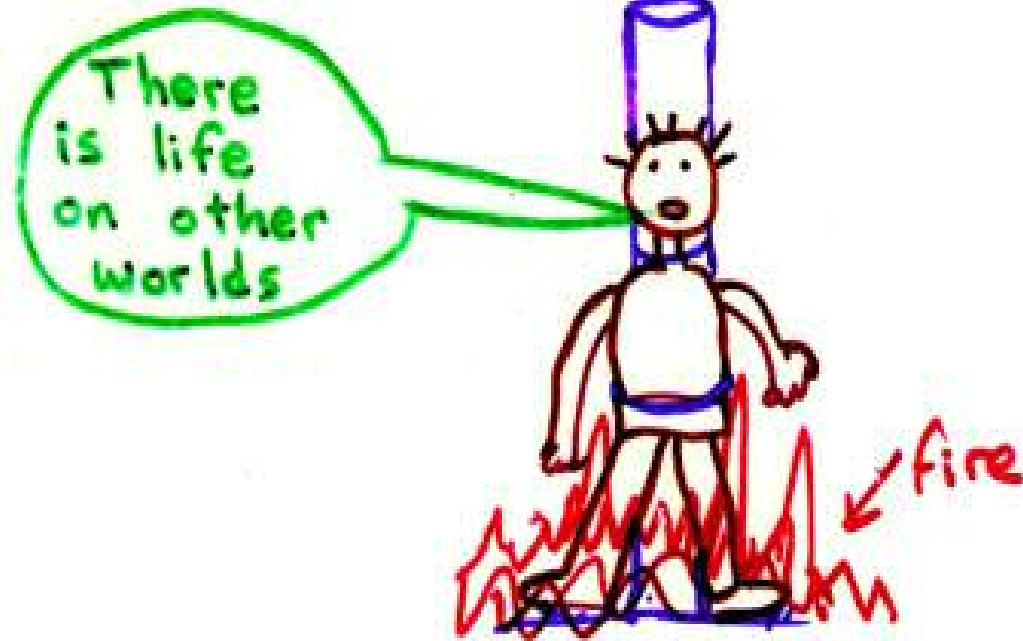

Giordano Bruno

1548 - 1600

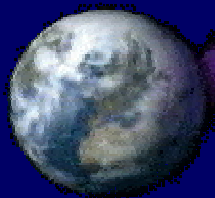



# Seti Haiku



# Searching for life Answers are revealed About ourselves

Paula Cook, Duke University



# One million earthlings Bounded by optimism Leave their PC's on

Dan Seidner



**Seti.berkeley.edu**

