



**Lawrence Livermore National Laboratory
University of California
Livermore, California 94551**

UCRL-ID-135639

Nitrate and Perchlorate Removal from Groundwater by Ion Exchange

Pilot Testing and Cost Analysis

Authors

**Stephany Burge*
Rolf Halden**

September 8, 1999

*University of Idaho Moscow, Idaho



**Environmental Protection Department
Environmental Restoration Division**

DISCLAIMER

This document was prepared as an account of work sponsored by an agency of the United States Government. Neither the United States Government nor the University of California nor any of their employees, makes any warranty, express or implied, or assumes any legal liability or responsibility for the accuracy, completeness, or usefulness of any information, apparatus, product, or process disclosed, or represents that its use would not infringe privately owned rights. Reference herein to any specific commercial product, process, or service by trade name, trademark, manufacturer, or otherwise, does not necessarily constitute or imply its endorsement, recommendation, or favoring by the United States Government or the University of California. The views and opinions of authors expressed herein do not necessarily state or reflect those of the United States Government or the University of California, and shall not be used for advertising or product endorsement purposes.

This report has been reproduced
directly from the best available copy.

Available to DOE and DOE contractors from the
Office of Scientific and Technical Information
P.O. Box 62, Oak Ridge, TN 37831
Prices available from (423) 576-8401

Available to the public from the
National Technical Information Service
U.S. Department of Commerce
5285 Port Royal Rd.,
Springfield, VA 22161

Nitrate and Perchlorate Removal from Groundwater by Ion Exchange

Pilot Testing and Cost Analysis

Authors

**Stephany Burge*
Rolf Halden**

September 8, 1999

*University of Idaho Moscow, Idaho

**Environmental Protection Department
Environmental Restoration Division**

TABLE OF CONTENTS

Summary	2
Introduction	2
Theory	4
Ion Exchange Test Unit	5
Ion Exchange Pilot Testing	7
Results and Discussion	7
Conclusion	12
Acknowledgements	13
References	13
Appendix A – Pilot Testing Procedure	
Appendix B – Data	
Appendix C – Hach Test Kit Results	
Appendix D – Perchlorate Tests and Predictions	
Appendix E – Cost Analysis	
Appendix F – Sample Calculations	
Appendix G – Optimized Regeneration Cycle Times	

SUMMARY

This study was conducted to evaluate the performance of a small scale ion exchange unit (Krudico, Inc of Auburn, IA) for removal of nitrate and perchlorate from groundwater at Lawrence Livermore National Laboratory's Site 300. The unit was able to treat 3,600 gallons of Site 300 groundwater, at an average influent concentration of 100 mg/L NO_3^- before breakthrough occurred. The unit contained 2.5 ft³ of Sybron SR-7 resin. Seventy gallons of regeneration waste were generated (water treated to waste ratio of 51:1). The effluent concentration was about 20 mg/L NO_3^- , which is equivalent to a treatment efficiency of at least 80%.

There are several options for implementing this technology at Site 300. A target well, in the 817 area, has been selected. It has a 3 to 4 gpm flow rate, and concentrations of 90 mg/L NO_3^- and 40 $\mu\text{g/L}$ perchlorate. The different treatment options include ion exchange treatment of nitrate only, nitrate and perchlorate, or perchlorate only.

Option 1

For the treatment of nitrate only, this unit will be able to treat 3,700 gallons of water before regeneration is required. If both columns of the ion exchange unit are used, 7,400 gallons could be treated before the columns will need to be regenerated (producing 140 gallons of waste, per cycle or every 1.5 days). The effluent nitrate concentration is expected to be about 17 mg/L. Annual operation and maintenance costs are estimated to be \$0.14 per gallon of water treated.

Option 2

If only perchlorate is to be removed with ion exchange at the 817 area, a smaller unit should be considered. A 55 gallon canister filled with ion exchange resin should be able to reduce perchlorate concentrations in the groundwater from 40 $\mu\text{g/L}$ to non-detect levels for three years before the resin would need to be replaced. The contaminant-laden resin would be disposed of as hazardous waste. It is not practical to regenerate the resin because of the extreme difficulty of removing perchlorate from the resin. Due to the selectivity of the ion exchange resin, it will also be possible to selectively remove perchlorate from nitrate-contaminated water. Annual operation and maintenance costs are estimated to be \$0.02 per gallon of water treated.

Option 3

Another alternative is to treat both perchlorate and nitrate. A three column unit would be built. The first column would capture perchlorate and the resin would be replaced rather than regenerated. The second and third column would be operated as under Option 1 to treat nitrate. Annual operation and maintenance costs are estimated to be \$0.14 per gallon of water treated.

INTRODUCTION

Site 300 is on the National Priorities List as a Superfund Site because its groundwater is contaminated with numerous compounds including volatile organic chemicals (VOCs), nitrate, and perchlorate (Figure 1). This paper focuses only on the removal of the latter two compounds via an ion exchange process. Ion exchange has been extensively studied for the removal of nitrate from

drinking water sources.¹ Other studies have suggested that some ion exchange resins can be used to remove perchlorate.²

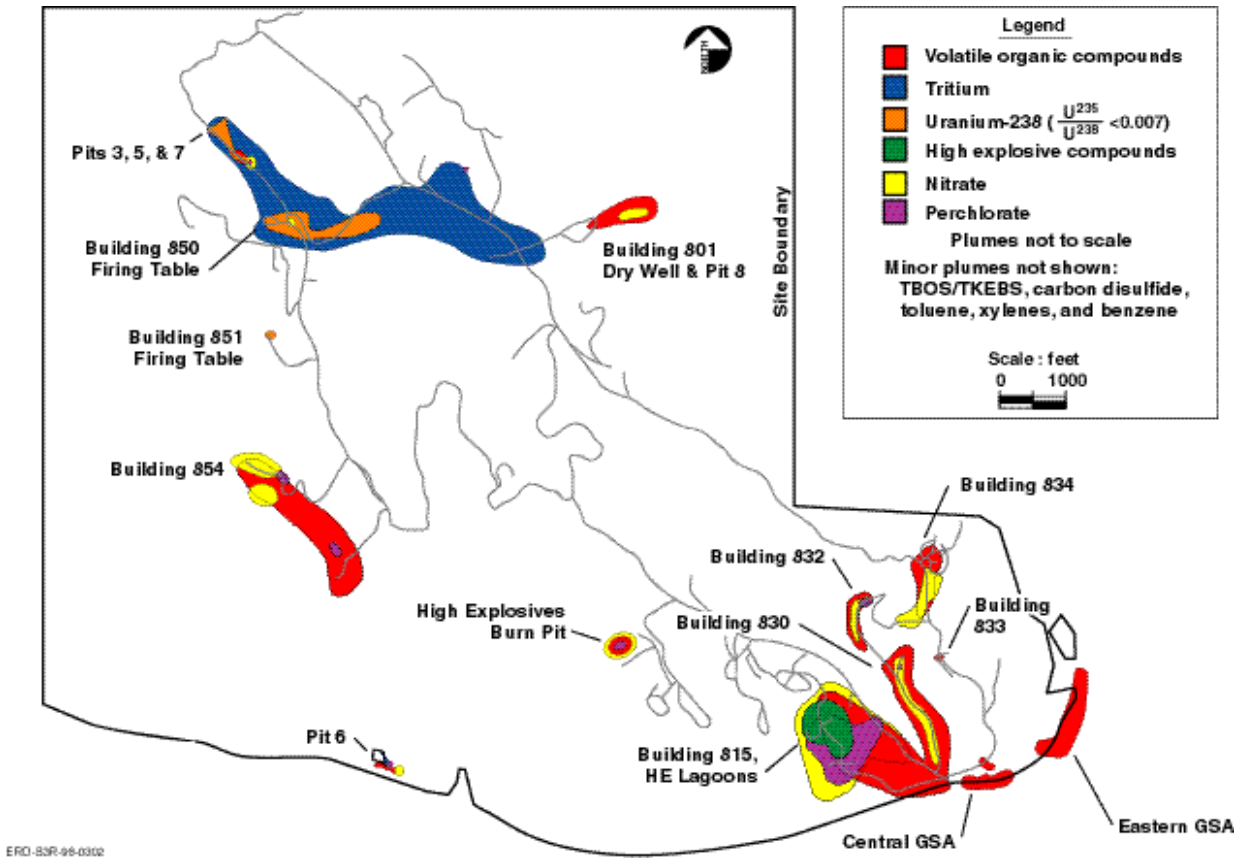

Figure 1: Extent of groundwater contamination at Site 300.

A test scenario has been developed for later comparison of the various remedial technologies. This scenario represents the data observed at the target well W-817-03, which is located in the 817 area of Site 300. The physical parameters associated with the well are a 3 to 4 gpm flow rate, and concentrations of 90 mg/L NO₃⁻ and 40 µg/L perchlorate.

The discharge limit for either compound has not yet been set (Table 1). For perchlorate, the discharge limit may be set at background levels, which are equivalent to the current detection limit of less than 4 µg/L. Nitrate discharge limits may either be the maximum contaminant level (MCL), background level, or the detection limit (less than 0.5 mg/L NO₃⁻). Contaminant background levels vary across the site and have not been determined for the 817 target area. Overall, it has been estimated that discharge limits will be set between 20 and 45 mg/L NO₃⁻ at Site 300.

Table 1: Summary of the concentrations, background levels and regulatory limits for nitrate and perchlorate in the 817 target area

Contaminant of Concern	MCL or Action level	Concentration at W-817-03	Background Levels	Estimated Discharge Limits
Nitrate	45 mg/L (as NO ₃ ⁻)	90 mg/L	Undetermined	Background to MCL
Perchlorate	18 µg/L ^a	40 µg/L	Non-detect ^b	Non-detect ^c

^aAction level may be increased to 32 µg/L. ^bMinimum detection level is 4 µg/L ^cMinimum detection level is 0.5 mg/L NO₃⁻

THEORY

Ion exchange resins exploit functional groups that are initially bonded to chloride ions. The resin used in this experiment consists of a styrene-divinylbenzene copolymer attached to a quaternary amine functional group.

When contaminated water flows over the resin beads, the chloride ion is exchanged for a nitrate or perchlorate ion because of its relatively higher affinity for the quaternary amine group (Figure 2). The chloride ion flows out with the effluent stream, while the exchanged ion remains bonded to the functional group. When all of the resin's functional groups have been bonded to contaminant anions, the resin is saturated. The resin is then regenerated with a saturated sodium chloride brine solution. Due to the regeneration solution's high concentration of chloride ions in relation to the contaminant ions on the resin, the chloride will displace the contaminant from the resin's functional group. The resin is then rinsed with the process water and returned to service. The regeneration wastewater is collected and disposed of as industrial wastewater.

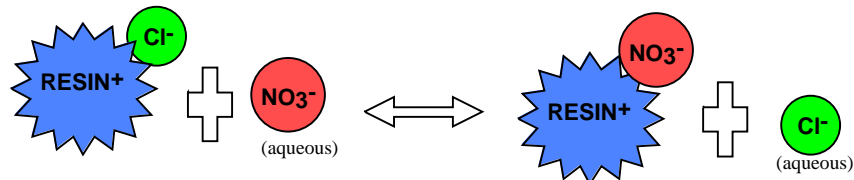

Figure 2: Ion exchange reaction mechanism for anion specific resin.

The resin also attracts similar anions including carbonate and sulfate. Nitrate specific resin has been proven to have affinity for the following ions in decreasing order.³



It has been suggested that perchlorate has a higher affinity for the resin than that of nitrate.⁴ Depending on the concentrations of alternate ions (mainly sulfate), premature leakage of nitrate and possibly perchlorate can occur. Leakage occurs when some of the contaminant ions appear in the effluent water beginning immediately after startup and continuing until breakthrough occurs.

ION EXCHANGE TEST UNIT

Several different resins were evaluated in a previous in-house study, including one general anion resin and three nitrate specific resins.⁵ Based on this study, a test unit containing the nitrate specific Sybron SR-7 resin was selected for pilot testing (Figure 3). Specifications for the test unit are summarized in Table 2.

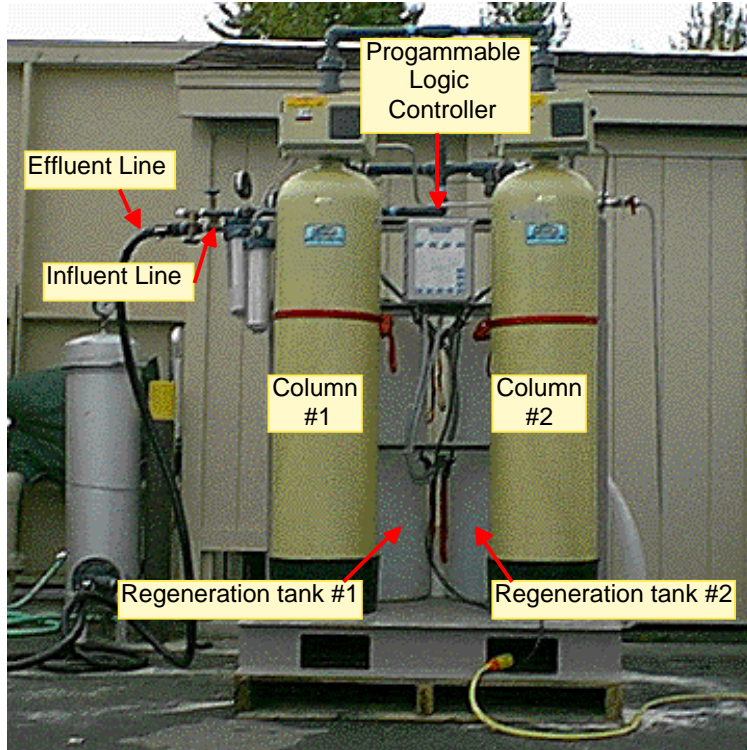

Figure 3: Krudico’s alternating dual tank nitrate removal ion exchange unit, which was used in this pilot study.

Table 2: Krudico’s ion exchange unit’s operational parameters and associated costs.

	Operating Flow	Maximum Flow	Minimum Flow	Resin Quantity
One Column Mode	7.5 gpm	12.5 gpm	4 gpm	2.5 ft ³
Two Column Mode	15 gpm	25 gpm	8 gpm	5.0 ft ³
Item	Cost		Quantity	
Krudico 15 gpm Ion Exchange Unit	\$10,000		1	
Sybron SR-7 Resin	\$280/ft ³		5 ft ³	

This ion exchange unit operates as an alternating dual tank system. Both tanks are operating in parallel until a preset volume of water has passed through the flow totalizer. Regeneration of Column #1 will be initiated automatically by the programmable logic controller. Column #1 will

return to service as soon as the regeneration cycle has been completed (98 minutes), thereby allowing regeneration of Column #2. Alternatively, this unit can be run in a single tank mode where only Column #1 is operated.

Pilot studies were conducted at the B834 treatment facility, Site 300. Groundwater from the treatment facility, which had been treated to remove VOCs, served as the influent source for the ion exchange unit as shown in Figure 4. Since B834 operated in batch mode, it was necessary to collect the batches of influent water in dual 1,000 gallon misting tanks before the tests could begin. Groundwater was run through the ion exchange unit and collected in a 2,000 gallon storage tank. When the influent misting tanks were drained, nitrate treated water was returned to the misting tanks and subsequently discharged (via air misting). The regeneration waste was collected in lined 55 gallon drums.

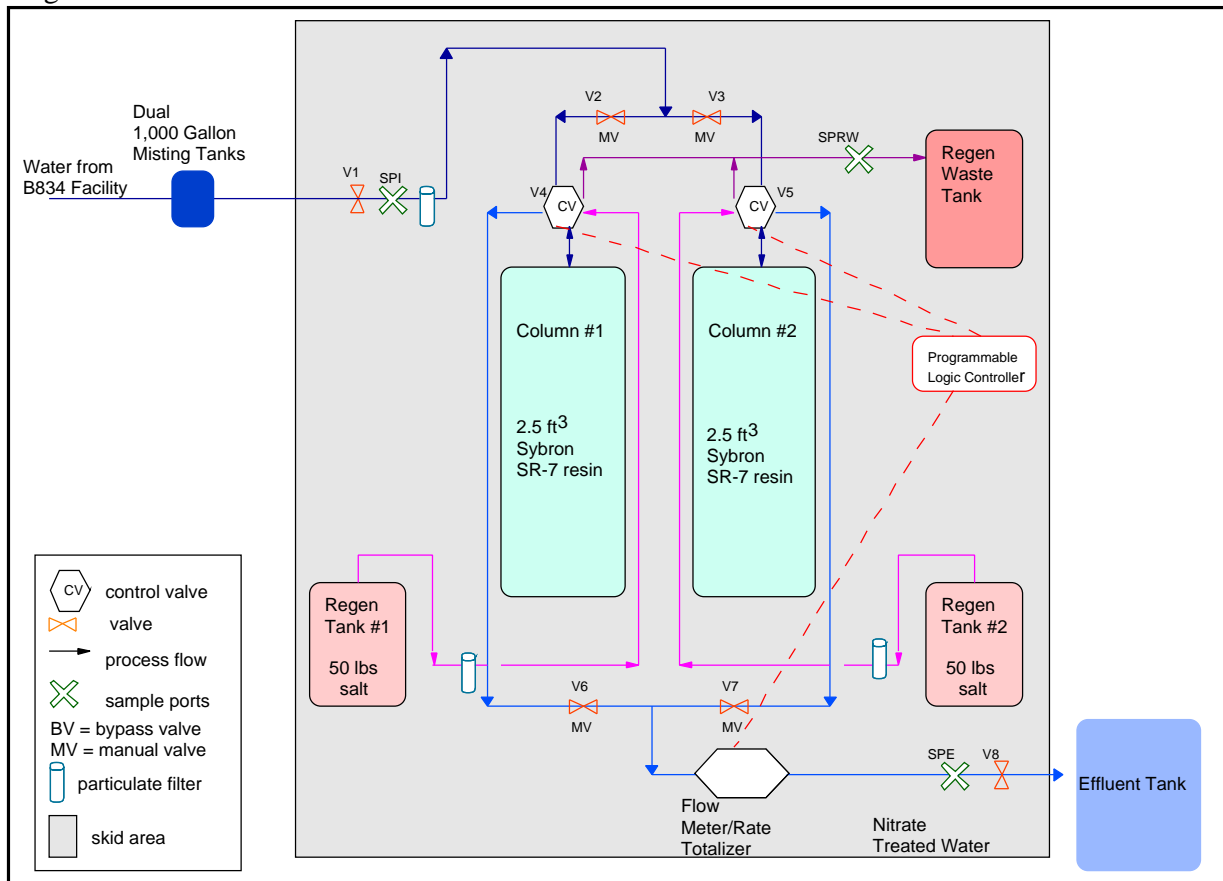

Figure 4: Process and instrumentation diagram for ion exchange unit when deployed during pilot tests at the B834 treatment facility.

Although the regeneration waste is not considered hazardous, the wastewater could not be disposed of through the sanitary sewer. The wastewater salt concentration was well above the City of Livermore discharge limits. Filled waste drums were shipped to the Hazardous Waste Management (HWM) group's interim storage facility. Drums were then disposed of as industrial wastewater.^{6,7}

ION EXCHANGE PILOT TESTING

Summary of procedure to test nitrate removal

Three different trials were conducted during this pilot study to measure the unit's efficiency for removal of nitrate only. The complete test procedure is included in Appendix A. The data for all of the trials is included in Appendix B. In Trial A, data was analyzed using Hach field test kits rather than laboratory analysis by ion chromatography. Due to the high variability of the Hach test kits results, Trial A data are not considered in this report. The Hach test kit results are included in Appendix C.

In the interest of time, the ion exchange unit was run in single column mode. Treated water from B834 had an average influent concentration of 43 mg/L NO_3^- (below the MCL). Therefore, the influent water was spiked to approximately 100 mg/L NO_3^- for Trials B and C. Samples were collected at approximately 1.5 hour intervals. The unit was run until breakthrough was observed. The operating column was then regenerated. All samples collected during Trials B and C were analyzed by BC Laboratories, Bakersfield.

Perchlorate bench top study

Two bench top batch experiments were performed to determine the ability of the Sybron SR-7 to remove perchlorate from nitrate contaminated groundwater. A complete description of these tests and the results are included in Appendix D.

The first experiment determined whether or not Sybron SR-7 is capable of removing perchlorate from Site 300 nitrate contaminated groundwater. Four liters of Site 300 groundwater were spiked to a perchlorate concentration of 27 $\mu\text{g/L}$. The nitrate concentration was estimated to be 60 mg/L NO_3^- . The water was poured through a column (3" inch diameter) filled with Sybron SR-7 resin (46 inches³). Samples were taken when 2 and 3.5 liters of groundwater had passed through the column. The water flowed through the column at approximately 0.62 gpm, or 17% greater than the required minimum flow rate for this quantity of resin.

The second experiment sought to determine the selectivity of the resin for perchlorate over that of nitrate. A sample of resin (0.5 grams) was pre-saturated with nitrate by immersion in a nitrate solution (300 mg/L NO_3^-) and mixed for 24 hours. The same resin was then transferred to a solution containing 130 $\mu\text{g/L}$ perchlorate and approximately 105 mg/L NO_3^- . This mixture was agitated for 24 hours. The second solution was analyzed for perchlorate concentrations before and after exposure to the resin. Perchlorate concentrations were measured by CalTest Laboratories, Napa.

RESULTS AND DISCUSSION

Removal of nitrates

The combined data from Trials B and C are presented in Figure 5. The weighted average influent concentration was 100 mg/L NO_3^- for both trials. A greater operating time was achievable (prior to breakthrough) during Trial C, hence greater error bars for the latter part of the effluent and removal efficiency curves. This is probably due to a more effective regeneration of the resin prior to Trial C compared to that preceding Trial B. Data from Trial A are not included here because the data were

disrupted by numerous operational difficulties, as well as the high variability of the Hach test kit results.

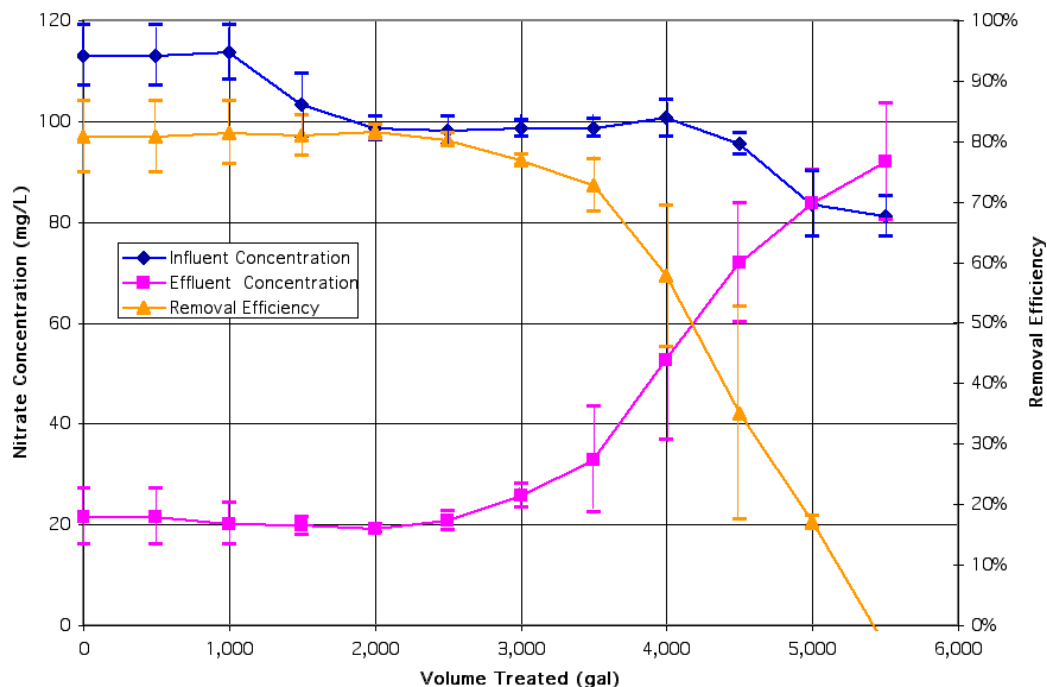

Figure 5: Combined removal efficiency and breakthrough data for Trials B and C using Sybron SR-7 resin during pilot testing. Average weighted influent nitrate concentration was 100 mg/L NO₃⁻.

Actual and predicted performance data are summarized in Table 3. The 817 target scenario results were obtained by using average experimental values (Trial B and Trial C) and breakthrough predictions from Sybron Resin literature (Appendix B). The regeneration removal efficiency was estimated to be 95%. Krudico, Inc. predicted a removal rate of 92% to 93%. Although Trial B reported a 100% removal rate, a more conservative 95% removal efficiency was assumed.

Table 3: Summary of performance statistics for Trial B, Trial C at the B834 test area and the Site 300, 817 target scenario during single column operation mode.

Single Column Mode	Trial B	Trial C	817 Target Scenario ^a
Weighted Influent Concentration	100.8	100.2	90.0
Effluent Concentration	17.3	23.3	17.3
Average Removal Efficiency	83.9%	77.6%	80.8%
Gallons treated before breakthrough begun	2,700	3,640	3,700
Mass of nitrate removed (kg) during operation	1.27	1.33	1.26
Regeneration Salt Type	Fine Grain Food Grade Salt	Culligan Solar Salt	Culligan Solar Salt
Nitrate removed (kg) during regeneration	1.32	1.27	1.20
Calculated efficiency of regeneration cycle	100%	95.2%	95.0%
Gallons of regeneration waste produced	69.2	70.9	70.0
Water treated to waste ratio	39:1	51:1	52:1

^a Values in italics are an average of Trial B and Trial C data. Remaining values are based upon predictions from Sybron literature.

The data in Table 3 indicates that, when implemented in the 817 area at Site 300, the unit will need to be regenerated every 3,700 gallons, which is equivalent to 0.74 days. To allow for longer operation, both columns can be operated at a combined flow rate of 15 gpm. The unit would then be regenerated after 7,400 gallons (1.5 days) and produce 140 gallons of waste per cycle. The amount of nitrate leakage was estimated to be 17.3 mg/L NO₃⁻.

Two different types of salt were tested during these tests. In Trial B, a fine grain food grade sodium chloride salt was used. This is also the salt currently used for regeneration of hexavalent chromium ion exchange resin at Treatment Facility D. Krudico suggested the use of a solar salt (diameter of approximately one centimeter). With the use of the solar salt, fewer problems were encountered and a higher salt concentration was observed in the regeneration brine (Figure 6). The food grade salt was difficult to dissolve and subsequently clogged the regeneration tank inflow line. Use of the food grade salt will require mixing prior to each regeneration, whereas solar salt can be left in the regeneration tanks where it will saturate the automatically refilled water over a relatively longer period of time. Additional salt must be added after the fourth regeneration cycle has been completed (or every five days at a 3.5 gpm flow rate and a column flow rate of 15 gpm).

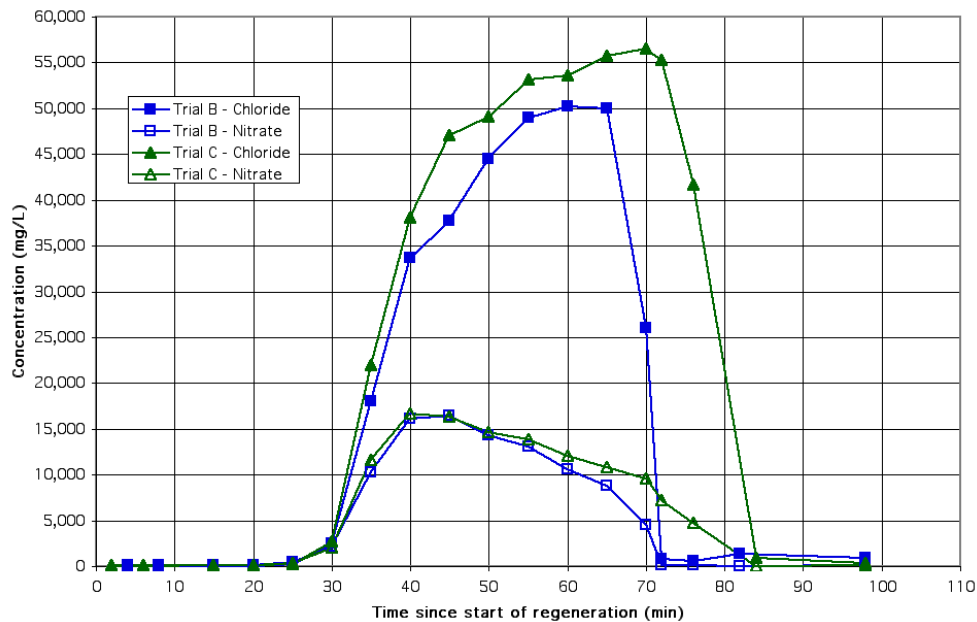

Figure 6: Nitrate and chloride concentrations versus time during regeneration of Trial B and Trial C. Fine grade food salt was used in Trial B. Solar salt was used in Trial C.

Although many commercial facilities using ion exchange technology can dispose of their waste via sanitary sewer, this is not the case at Site 300. The waste must be disposed of as industrial waste through the HWM group. ERD does not pay for these costs directly, but that may change at some point in the future. Therefore, the waste disposal costs are included in the cost estimate.

There are some modifications that can be made to reduce the volume of regeneration waste produced. Dennis Clifford, of the University of Houston, has conducted several studies to demonstrate a system in which the brine waste is recycled⁸. The brine is denitrified in a biological sequencing batch reactor and then recycled back into the system. This could reduce the amount of

waste produced by up to 90%, but this modification's suitability for application at Site 300 would still need to be determined. Another alternative is to not discard the first 20 minutes of the waste produced during the regeneration cycle, which is permissible because the initial wastewater is very low in both nitrate and chloride concentrations. Thus this water could be recycled back into the influent treatment tanks. The volume of waste produced could be reduced by 33% per regeneration cycle (water treated to waste ratio of 79:1). This would require either significant modification of the ion exchange unit or a technician to be present during each regeneration cycle to allow for separation of the first 20 minutes of the regeneration waste stream.

Perchlorate treatment

In the first bench scale test, the influent concentration of perchlorate was 27 µg/L. According to lab analysis, the concentration was below the detection limit in both effluent samples. Similar results have been reported by other researchers.²

The results from the second bench scale test show that the perchlorate concentration in the second solution was non-detect after exposure to resin. This suggests that perchlorate has a higher affinity for the resins' functional group than nitrate does. The affinity may be so great that it will be extremely difficult to regenerate the resin. Another study used a similar Sybron resin and could only regenerate a fraction of the perchlorate loaded. The selectivity of the resin for perchlorate was 150 times greater than for chloride.²

One treatment option is to use the resin for perchlorate removal only and dispose of the saturated resin as hazardous waste. Theoretically, the unit can be run for up to three years (depending on the quantity, condition, and actual perchlorate selectivity of the resin) to treat 40 µg/L perchlorate groundwater to non-detectable levels. Experimental data and predictions are included in Appendix D. Before implementing this option, bench tests should be conducted to determine the minimum resin contact time needed for effective perchlorate removal.

Cost analysis

Several different applications of this technology have been suggested (Figure 7). The first option is to use the ion exchange unit only for treatment of nitrate. The second option is to treat only perchlorate and use a different technology to treat the nitrate contamination. The final option is to treat both nitrate and perchlorate with ion exchange technology. One column would be used to remove perchlorate. The next two columns would treat nitrate and be regenerated as normal.

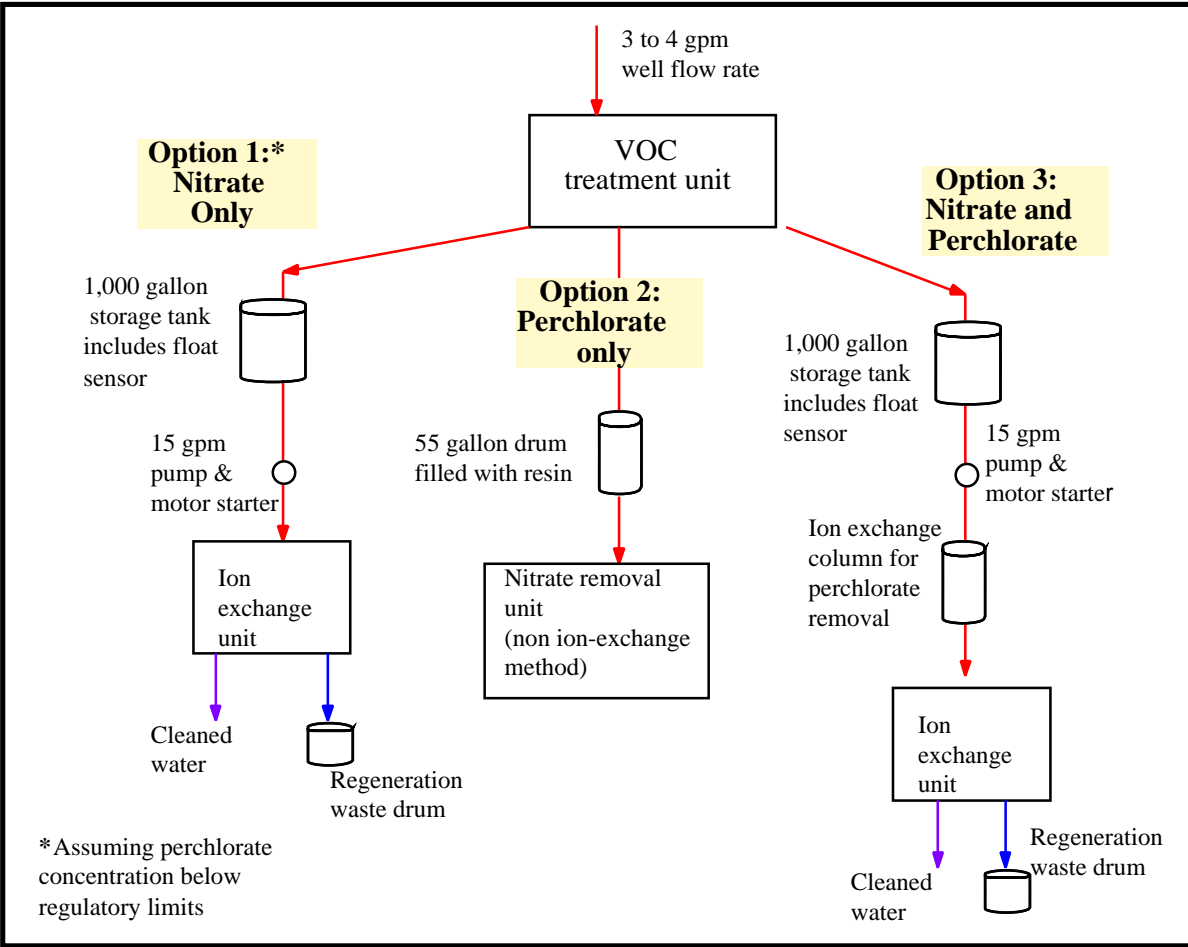

Figure 7: Overview diagram of various implementation options for the ion exchange unit.

Several modifications and operational considerations are necessary to include for the implementation of ion exchange at Site 300. Due to the high flow rate of the unit (7.5 to 15 gpm) compared to the scenario well flow rate of three to four gpm, it will be necessary to include a collection tank, automatic motor starter and appropriate controls for Options 1 and 3. Lower flow units are available, but would require a much more frequent regeneration. Options 1 and 3 will require fairly frequent maintenance, which includes refilling the regeneration tanks with salt, switching out regeneration waste drums, and monitoring the unit for nitrate breakthrough. The resin will also need to be replaced every two years in the nitrate removal ion exchange unit, due to calcium carbonate buildup (Options 1 and 3). The resin will need to be changed out every two to three years with Option 2 (Appendix D). Installation and operational costs associated with the various options are summarized in Table 4. The complete cost analysis is included in Appendix E.

Table 4: Summary of costs associated with various treatment options.

	Capital Costs	Total Setup/Installation Costs	Operations and Maintenance Costs per year	\$/gallon treated (overall) ^a	\$/gallon treated (yearly O&M)
Option 1 – Nitrate Only	\$15,700	\$25,600	\$258,400	\$0.15	\$0.14
Option 2 – Perchlorate Only	\$2,300	\$4,300	\$37,200	\$0.02	\$0.02
Option 3 – Nitrate and Perchlorate	\$17,700	\$27,600	\$263,300	\$0.16	\$0.14

^a \$/gallon water treated is based upon an annual average flow rate of 3.5 gpm (1,839,600 gallons total).

CONCLUSION

Ion exchange technology can be used to treat nitrate only. This usage has been well established and commercial units are easily available. This option is best implemented at wells with high flow rate and low concentrations of nitrate. With the addition of an influent storage tank, the test unit can be operated with intermittent or low flow wells. Unfortunately, a significant amount of regeneration waste is created in either case. Due to the high cost associated with waste disposal (\$220k per year), this technology may not be economically favorable. In addition, the leakage rate of 20% of the influent nitrate concentration may limit the application of this technology. If the discharge limits are set above 18 mg/L, the effluent nitrate concentrations may be too high to meet these requirements.

Another option is to use the unit to treat perchlorate only. In this case, installation could be reduced to an initially maintenance free flow through box. After a few years, the perchlorate saturated resin would be disposed (\$350/year). This would be a low cost, low maintenance solution for the removal of perchlorate from groundwater. Nitrate could be treated with other technologies which include air misting, bioremediation, or phytoremediation.

A final option is to use ion exchange technology to remove both nitrate and perchlorate. A unit could be built with three ion exchange columns. The first column would serve for perchlorate removal by irreversible sorption, which would require disposal of the exhausted resin. The second two columns would be used to remove nitrate. Disadvantages of using this approach have already been discussed and are primarily of an economic nature.

In conclusion, ion exchange will be effective in treating both perchlorate and nitrate. It may be cost prohibitive when targeting nitrate due to the high cost of waste disposal. For perchlorate, a simple unit can be built and operated inexpensively. This method does not destroy the perchlorate, but it can be easily implemented and is likely to be very effective.

ACKNOWLEDGEMENTS

I would like to also thank Tristan Pico and Ed Folsom for their guidance on this project. The technical support was provided by Marvin Lima and John Cunningham. Dick Woodward helped prepare the cost analysis.

REFERENCES

1. Kappor A, Viraraghavan T. "Nitrate Removal from Drinking Water - Review." *Journal of Environmental Engineering*. April 1997. 371: 380.
2. "Application of Ion-Exchange Technology for Perchlorate Removal from San Gabriel Basin Groundwater." Final project report submitted to Main San Gabriel Basin Watermaster by Montgomery Watson. April 6, 1999.
3. Harland, C.E. Ion Exchange: Theory and Practice. Royal Society of Chemistry. Cambridge, 1994.
4. Clifford, Dennis. Email conversation. March 4, 1999. DAClifford@UH.edu
5. Simon N, Kumamoto G, Pico T. "Removing Nitrate from Groundwater at Site 300 Using Ion Exchange." Lawrence Livermore National Labs. July 30, 1998. UCRL-ID-131062-98-1
6. Giesing, Ted. Memo from the Environmental Protection Department. December 4, 1998.
7. Mancieri, Sav. Memo from the Environmental Protection Department, Operations and Regulatory Affairs. May 4, 1999.
8. Clifford D, Liu X. "Ion Exchange with Denitrified Brine Reuse." *Journal of American Water Works Association*. 88.11 (1006): 88-99.

APPENDIX A

Pilot Testing Procedure

Nitrate Removal Ion Exchange Unit Optimization Studies – Pilot Testing Procedure 3X-046

Written: 1/12/99

Edited: 3/25/99

A-1.0 Purpose

The purpose of this procedure is to outline the steps that will be followed in the optimization study of the nitrate removal ion exchange unit. This unit will be tested at Building 834 on Site 300. The goal is to minimize waste production, salt usage and maximize the service cycle length. Data collected will be used to develop a set of breakthrough curves for both nitrate and perchlorate removal. In addition, the capacity of the resin, regeneration cycle efficiency and an overall cost estimate will be determined. Several types of data will be collected: flow rates, salt usage, influent and effluent nitrate & chloride concentrations, and pH levels. This experiment was preceded by a clean water flush at Livermore Site (LX-167).

A-2.0 Scope

The unit will be tested at Building 834 on Site 300. The unit will be placed at the misting pads. The influent line of the ion exchange unit will be connected to the two 1,000 gallon misting tanks located at B-834 misting pad. The two tanks will be filled with water from the B-834 treatment facility. The water will then pass through the ion exchange unit to two 1,000 gallon polyvinyl tanks. When the two misting tanks are empty, the water will be pumped back to the misting tanks and then air misted. This process will be repeated until a sufficient amount of water has flown through the ion exchange unit. This setup will allow for only a minimal impact on the Building 834 operations. Building 834 treatment facilities are designed to remove any VOC or TBOS contaminants from its influent water (well water). The effluent of B-834 will become the influent of the ion exchange unit. This water is referred to as “hard water” in this paper.

During the first part of this procedure, both tanks will be in service flow mode. In this stage, breakthrough curve data will be collected. Influent and effluent samples will be analyzed for chloride, nitrate and pH levels. These values will be plotted against bed volume (BV). Bed volume is defined as the volume of ion exchange resin material in the columns (or bed). After examining the plots, the maximum cycle length can be determined. Similar tests will be conducted using potassium perchlorate at a to be determined concentration, dependent on actual ambient influent perchlorate concentrations on a bench scale level. The resulting cycle lengths will be compared with predicted values based on the resin manufacturer’s equations. In addition, nitrate leakage due to presence of sulfate will be recorded.

The resin capacity will be determined using the influent and effluent nitrate concentration data. This is done by calculating the amount of nitrate entering the system and comparing it to the amount which exited the system before breakthrough. These results will be plotted against the varying concentrations of nitrates & perchlorates and the number of cycles completed. This information will be particularly valuable for the analysis of perchlorate removal, as very few literature values exist.

The next part of this procedure begins when Tank #1 begins to regenerate. The Programmable Logic Controller (PLC) has already been programmed for certain regeneration phase lengths. The first phase of the regeneration cycle is a backwash of the resin bed with hard water. The second phase is the brine tank fill/slow rinse. The resin tank is rinsed with the brine solution then slowly rinsed with hard water. The final phase of the regeneration cycle is the rapid rinse. During this stage, the residual brine waste will be rinsed off the resin with hard water. Tank #1 will complete the regeneration cycle and return to service. Tank #2 will be allowed to also complete a regeneration cycle. When tank #2 has returned to service, the flow to the unit will be shut off.

Table A1 outlines the regeneration phase lengths and sampling plan. The goal of this phase of the study is to reduce the amount of regeneration waste solution produced and the amount of salt used. This can be achieved through several methods. For instance, the vendor suggests discharging the backwash stage and the first ten minutes of the brine tank fill/slow rinse cycle to the air misting pads since neither of those waste streams contain brine or elevated levels of nitrates. By monitoring the chloride levels, the brine content in the regeneration waste stream can be determined.

Table A1: Regeneration Cycle Lengths and Sampling Plan

Cycle	PLC Setting	Collection Frequency	Analysis
Backwash	10 minutes	At 3 and 8 minutes	Nitrate pH
Brine Tank Fill/Slow Rinse	56 minutes	15 minute intervals At 30 minutes	Chloride Nitrate pH
Rapid Rinse		At 5 minutes	Chloride pH

The regeneration data will also be analyzed. The chloride and nitrate concentrations will be plotted against time from the start of each phase. The results will be interpreted to determine the necessary regeneration cycle lengths. The efficiency of the regeneration cycle will also be calculated. A nitrate removal rate of 90% to 92% is expected. The regeneration efficiency of perchlorate needs to be determined. Conversations with vendors and other people familiar with

this topic suggests that the regeneration of the resins loaded with perchlorate may be difficult. Assuming a maximum perchlorate concentration of 30 ppb and higher perchlorate affinity, perchlorate breakthrough is not expected until 13 million gallons have been treated.

After all collected data has been analyzed, modifications will be made to the PLC programming. This procedure will be repeated with the needed adjustments.

Nitrate levels will be measured with a Hach DR/890 colorimeter. The solution’s acidity will be measured with pH strips. Chloride levels will be monitored with a YSI salinity meter. Various samples will be sent for a GENMIN analysis. The analysis will report the level of nitrate, sulfate, chloride, and bicarbonate in the effluent or influent sample. A perchlorate analysis will have been done prior to air misting by the B834 crew.

Overall expected performance, time and waste generation of unit with ambient nitrate conditions, most times are approximate and may vary depending on conditions of test. Table A2 outlines the beginning performance statistics.

Table A2: Summary of Initial Ion Exchange Operating Cycles

Operation Mode	Length of Cycle	Water Source	Discharge Destination	Flow Rate (gpm)	Volume of Water Produced
Fill regeneration tanks with salt	5 min	None	none	none	None
Service Flow	5 hours	Influent	Misting Tanks	15	4000 gallons
Backwash Position	10 min	Influent	Regen Waste Tanks	1.5	15 gal
Brine draw/slow rinse	56 min	Regen Tanks	Regen Waste Tanks	0.8	84 gal
Rapid Rinse	6 min	Influent	Regen Waste Tanks	1.5	9 gal
Brine Tank Fill	40 min	Influent	none	15	None

A-1.0

A-2.0

A-3.0 References

- A-3.1 “NSF Equipment Verification Testing Plan for Nitrate Contaminant Removal by Ion Exchange Used in Package and/or Modular Drinking Water Systems for Small Public or Private Water Supplies.” NSF International. May 11, 1998.

Procedure

- A-3.2 Notification of interested parties
 - A-3.2.1 Notify Ed Folsom & Rolf Halden
 - A-3.2.2 Notify Rob Tagesson of Hazardous Waste Management Division
- A-3.3 Pre-test setup
 - A-3.3.1 Collect the following:
 - A-a) DR 890 Colorimeter and nitrate ampules
 - A-b) YSI salinity meter
 - A-c) pH paper
 - A-d) Appropriate log book (ZB - Site 300 Misc. Log Book)
 - A-e) Sample bottles
 - A-f) Hazardous waste material tanks
- A-3.4 Setup at Site 300 (see Figure 1)
 - A-3.4.1 Tighten all valves and connectors to prevent leaks
 - A-3.4.2 Release the straps from the fiberglass tanks
 - A-3.4.3 Connect influent line to the 1000 gallon tank located at the misting pad at B-834
 - A-3.4.4 Connect regeneration drain line to hazardous waste containers
 - A-3.4.5 Connect effluent line to misting tower or to appropriate tank

A-3.4.6 Figure A1: Setup at Building 834

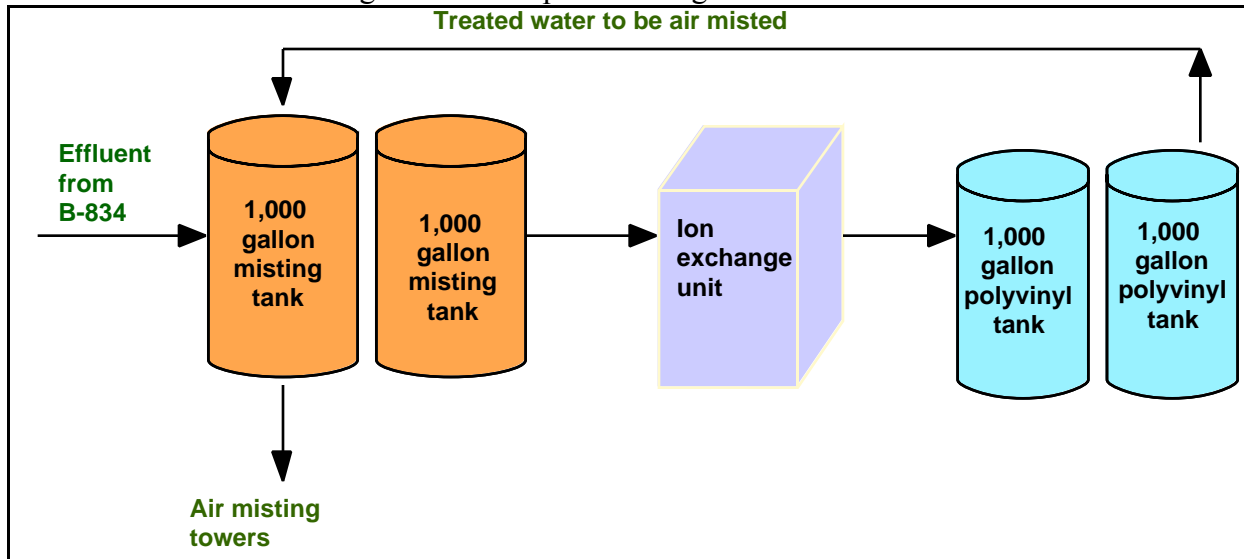

A-4.0 Trial A Instructions

A-4.1 Run water through unit (see Figure 2)

A-4.2 Turn PLC on.

A-4.3 Reset capacity setting to 15000 gallons.

A-4.4 Press and hold System Program button for 30 seconds

A-4.5 Press System Program button 7 times to advance to the Capacity setting

A-4.6 Using the up and down arrows, reset the total capacity to 8000 gallons

A-4.7 Return to normal operation by pressing the System Display button

A-4.8 Using PLC (Brine Draw/Slow Rinse setting), fill regeneration tanks with 10 gallons of water

A-4.9 Manually dump one half of a 50 pound bag of regeneration salt into each regeneration tank.

A-4.10 Open Valve 1 and Valve 8, allow water to flow through system.

A-4.11 Using flow rate meter, adjust influent pressure such that the flow is 15 gpm by manipulating Valve 1.

A-4.11.1 Figure A2: Overall System Layout and Labels

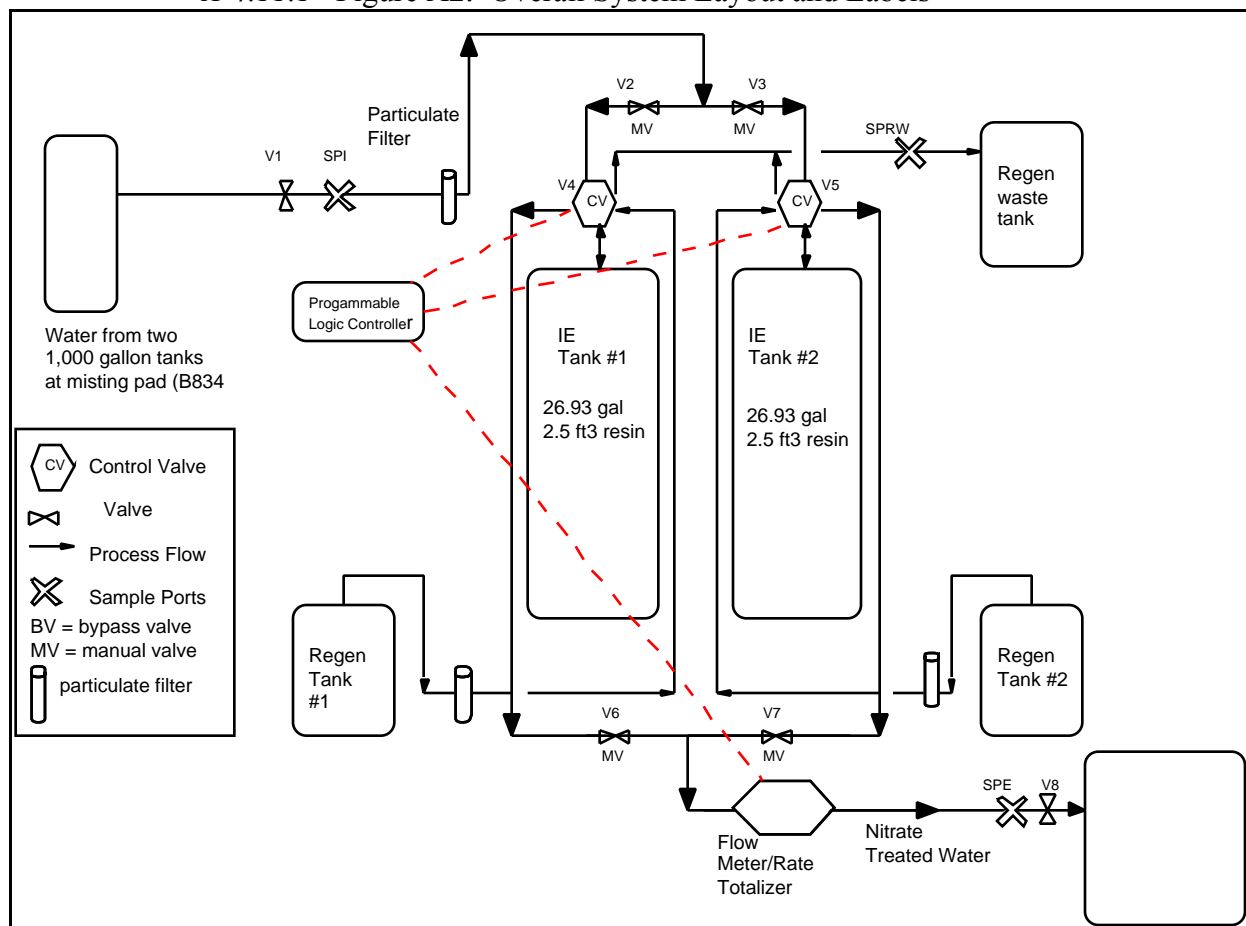

A-4.12 Collection of initial data (See Section 5.0 - Data Sheets)

A-4.13 Run 2,000 gallons of water through the unit, allow the water to be resent to B-834 and the tanks to be refilled. Repeat this practice until breakthrough is observed.

A-4.14 At 250 gallon intervals, collect influent and effluent samples. Using pH test strips, record pH. Record nitrate levels using DR 790 colorimeter.

A-4.15 At 1000 gallon intervals, analyze the sample for chloride levels using the alkalinity meter.

A-4.16 Plot influent, effluent nitrate, pH and effluent levels against bed volume. Bed volume is calculated by dividing the total flow reading by 18.70 gallons (or 2.5 ft³ of resin).

A-4.17 Compare breakthrough point with that predicted by Sybron literature (*see attached calculations!*)

A-4.18 Regeneration of Tank #1

A-4.18.1 Stage 1: Backwash

A-a) This stage lasts 10 minutes (backwashes resin with hard water)

A-b) Collect nitrate and pH sample at 3 and 8 minutes

A-4.18.2 Stage 2: Brine Tank Fill/Slow Rinse

A-a) This stage lasts 56 minutes (washes resin with brine water)

- A-b) Collect chloride sample at 30 minutes
- A-c) Collect nitrate and pH samples at 15 minute intervals
- A-d) Using YSI chloride meter, monitor chloride levels. Record time when chloride levels return to ambient levels

A-4.18.3 Stage 3: Rapid rinse

- A-a) This stage lasts 6 minutes (rapidly rinses resin with hard water)
- A-b) Collect a chloride and pH sample at 4 minutes
- A-c) Allow Tank #1 to go back into service and Tank #2 to complete regeneration cycle
- A-d) Turn flow of water off to unit

A-5.0 Trial B Instructions

- A-5.1 Run water through unit
- A-5.2 Set PLC for single tank mode.
- A-5.3 Press and hold System Program button for 30 seconds
- A-5.4 Press System Program button 2 times to advance to the Unit Size setting
 - A-5.4.1 Using the up and down arrows, reset the unit size to one
 - A-5.4.2 Return to normal operation by pressing the System Display button
- A-5.5 The PLC will automatically begin to regenerate. A small 'r' will be visible on the PLC screen. Halt the regeneration cycle by unplugging the PLC and waiting 30 seconds. Plug PLC back in and progress to next step. Switching the PLC to single tank mode while in operation is the signal for the PLC to begin a regeneration cycle.
- A-5.6 Using PLC (Brine Draw/Slow Rinse setting), fill regeneration tanks with 10 gallons of water. If there is water already in the brine tank, determine whether or not the water is clean (ie does not contain regeneration waste). For Trial B, the water will need to be removed and disposed of in a hazardous waste drum. The brine tank water has high concentrations of salt and nitrates due to incomplete regeneration in Trial A.
- A-5.7 Manually dump one half of a 50 pound bag of regeneration salt into each regeneration tank (25 lbs). Use mixer to sufficiently agitate water and salt.
- A-5.8 Open Valve 1 and Valve 8, allow water to flow through system.
- A-5.9 Using flow rate meter, adjust influent pressure such that the flow is 15 gpm (or 30 liters per minute) by manipulating Valve 1.
- A-5.10 Collection of initial data (See Section 5.0 - Data Sheets)
- A-5.11 Take sample of water in B834 misting tanks. Using Hach Colormeter, determine initial nitrate concentration. Use attached spreadsheet to calculate how much sodium nitrate must be added to get a final solution of 100ppm. Analyze final solution with Hach kit and a dilution of 5:1. (Read height of water in misting tanks from B834. 56" represents 2000 gallons).
 - A-5.11.1 Run volume of water in misting tanks through the ion exchange unit, collecting effluent in large 2000 gallon tank.
- A-5.12 At one hour intervals, collect influent and effluent samples. Using pH test strips, record pH. Record nitrate and sulfate levels using DR 790 colorimeter.

- A-5.13 When the misting tanks are drained, open valves between large 2000 gallon tank and drain the water back into the misting tanks. Re-spike water to 100pm and repeat procedure until breakthrough is observed. Water may be air misted when required by B834 technicians
- A-5.14 Plot influent, effluent nitrate, pH and effluent levels against bed volume. Bed volume is calculated by dividing the total flow reading by 18.70 gallons (or 2.5 ft³ of resin). Also plot the removal efficiency versus the volume of water treated.
- A-5.15 Compare breakthrough point with that predicted by Sybron literature (*see Calculations*) using weighted average influent nitrate concentrations.
- A-5.16 Regeneration of Tank #1
- A-5.17 When breakthrough has been achieved, a regeneration of Tank 1 will need to be initiated. This involves several steps including resetting the PLC to two tank mode and changing the lengths of the various PLC settings.
- A-5.18 Press and hold System Program button for 30 seconds
- A-5.19 Press System Program button 2 times to advance to the Unit Size setting
- A-5.20 Using the up and down arrows, reset the unit size to one
- A-5.21 Press System Program button to advance to Regeneration Cycle Mode. Change the brine draw/slow rinse setting to 160 minutes (In the previous trial, it was determined that the initial setting was too short to complete the brine draw and slow rinse cycle. Only the brine draw phase was completed in Trial A).
- A-5.22 Return to normal operation by pressing the System Display butt
- A-5.23 Stage 1: Backwash
- A-5.23.1 This stage lasts 10 minutes (backwashes resin with hard water)
 - A-5.23.2 Collect nitrate and pH sample at 3 and 8 minutes
- A-5.24 Stage 2: Brine Tank Fill/Slow Rinse
- A-5.25 This stage lasts for an undetermined time (rinses resin with brine water, rinses brine water off resin). Using the salinity meter, sample frequently to determine when the water coming from the regeneration waste line is free of salt. Record time when all brine has been drawn from tank. Record time when all brine has been rinsed from column.
- A-5.26 Collect samples as described on data sheets.
- A-5.27 Stage 3: Rapid rinse
- A-5.27.1 This stage lasts 6 minutes (rapidly rinses resin with hard water)
 - A-5.27.2 Collect a chloride and pH sample at 3 and 6 minutes
 - A-5.27.3 Stop PLC from regenerating Tank Two by advancing out of regeneration cycle. Press Manual Regeneration Button (or Unit 2 Display) to step the unit through the various regeneration cycles.
- A-5.28 Turn flow of water off to unit

APPENDIX B

Data

Trial A Data

TRIAL A - Raw Data

Nitrate data was determined using Hach Test kits

Date	Time	Total Flow Reading liters	Flow Rate 1 pm	Influent Nitrate mg/L	pH	Effluent Nitrate mg/L	pH	Notes
1/21/99	12:41	1762	59.1					
		2783	58.3					
	13:25	4054	58.2					
		4123		8.5	7	0.3	7	
	13:45	5226						
1/27/99	9:32	5226						
		5238						Switched PLC to run one one column at 7.5gpm/column, outdoor flow meter stuck at 1gpm, PLC stopped reading flow, operation stopped
		5983	30.8					Don fixed outdoor flow meter, PLC iniated regeneration, Marvin halted, turned all valves to lag tank shut, test resumed
	10:12	5999	31.2					
		7358						Sulfate measured at 80ppm+ (beyond limits of colorimeter?), realized that have been doing nitrate analysis wrong! need to zero with sample not di water, 1/28/99 redid suflate test with correct blank still read 80+
	11:00		30					Eric performed chemetrics test also. Got 6.55 as N!!
		7376		9.45		0.9		
	12:30	10245	30					
		10267		9.75		0		Eric got 47ppm with chemetrics, hach 43, genmin anal 58
		11313		9.75		1		
		11513		8.9		0.3		
		11547	29.9					
2/3/99	10:09	11583						Concentrations may be so low due to recent heavy rains.
	11:37	14216	30					
		14256		5.7	7	0.7	7	
	13:31	17647	29.9	5.1		0.5		
	14:25	19240						
2/9/99	11:49	19241	30.8					Exterior flow meter not working
	13:33	22505	31.7	5.3		0.6		More rain....
	15:15	25749	31.7	5.7		0.7		
	15:59	26033						
2/16/99	10:35	27747	29.7	5.45				Spiking attempt#1
		27932		11.1		2.5		
	11:38	20606	29.6					
		29636		11.6		2.9		
	12:46	31631	29.6	12.8		3.3		
	13:31	33152	29.7	12.1		3.6		Took sample of water before filter, 10.4!!
2/19/99	12:25	34269	28.2	74.4		28		Switched colorimeter to read NO3 rather than N
	13:04	35404	29.3	83.2		43		Spiking attempt #2
	13:30	36165	29.5	78		56.6		
	13:58	36991	29.7	71.8		60.6		
	14:31	37956	29.1	69.8		69.2		
	15:01	38825		77.4		70.2		Breakthrough Declared!!!
3/2/99	12:42	47539	30	86.6		27.4		Regen attempt failed, fixed regen cycle, resaturated column
	14:18	50480	30	67.4		25.5		
		50750	30	64.7		70.7		
	15:20	52345						
3/3/99	11:00	52666	30.9					
		56866		76.2		72		
	13:51	57863	30.5	68		77.6		breakthrough achieved again

TRIAL A - Breakthrough Curve Data									
All values used are from actual Hach Kit readings									
	Flow Meter Reading (liters)	Total Flow (liters)	Influent NO3 Conc (mg/L)	Effluent NO3 Conc (mg/L)	Influent NO3 amount (g)	Effluent NO3 Amount (g)	Nitrate Removed (g)	Removal Efficiency	Notes
Batch #1		617	34.99	2.21	21.59	1.37	20.23	93.67%	
1/21/99		1155	40.30	3.54	20.24	1.55	18.69	92.35%	
		2335	37.64	2.21	46.01	3.40	42.61	92.61%	
Batch #2	7376	4485	41.85	3.99	85.45	6.67	78.79	92.20%	
1/27/99	10267	7376	43.18	2.21	122.91	8.96	113.95	92.71%	
	11313	8422	43.18	4.43	45.16	3.47	41.69	92.31%	
	11513	8622	39.41	2.21	8.26	0.66	7.60	91.96%	
Batch #3	14256	11365	25.24	3.10	88.68	7.29	81.39	91.78%	Heavy rains
2/3/99	17647	14756	22.59	2.21	81.09	9.01	72.08	88.89%	
Batch #4	22505	19614	23.47	2.66	111.87	11.83	100.04	89.42%	Heavy rains
2/9/99	25749	22858	25.24	3.10	79.01	9.34	69.68	88.18%	
Batch #5	27932	25041	49.16	11.07	81.21	15.47	65.74	80.95%	Still raining
2/10/99	29636	26745	51.37	12.84	85.65	20.37	65.28	76.21%	Spiked
	31631	28740	56.69	14.61	107.79	27.39	80.40	74.59%	
	33152	30261	53.59	15.94	83.86	23.24	60.62	72.29%	
Batch #6	34269	31378	74.40	28.00	71.48	24.54	46.94	65.67%	Spiked
2/19/99	35404	32513	83.20	43.00	89.44	40.29	49.15	54.95%	
	36165	33274	78.00	56.60	61.34	37.90	23.44	38.21%	
	36991	34100	71.80	60.60	61.87	48.40	13.46	21.76%	
	37956	35065	69.80	69.20	68.32	62.63	5.69	8.33%	
	38825	35934	72.40	70.20	61.79	60.57	1.22	1.97%	
				Average Influent Nitrate Concentration:			49.40		
				Total Nitrate Removed (kg):			1.06		
				Weighted Average Influent Concentration:			41.27		
				Weighted Average Effluent Concentration:			11.81		
				Total Liters Treated:			35934		
				Total Gallons Treated:			9491		

Trial A - Breakthrough Chart
Actual Hach Kit readings

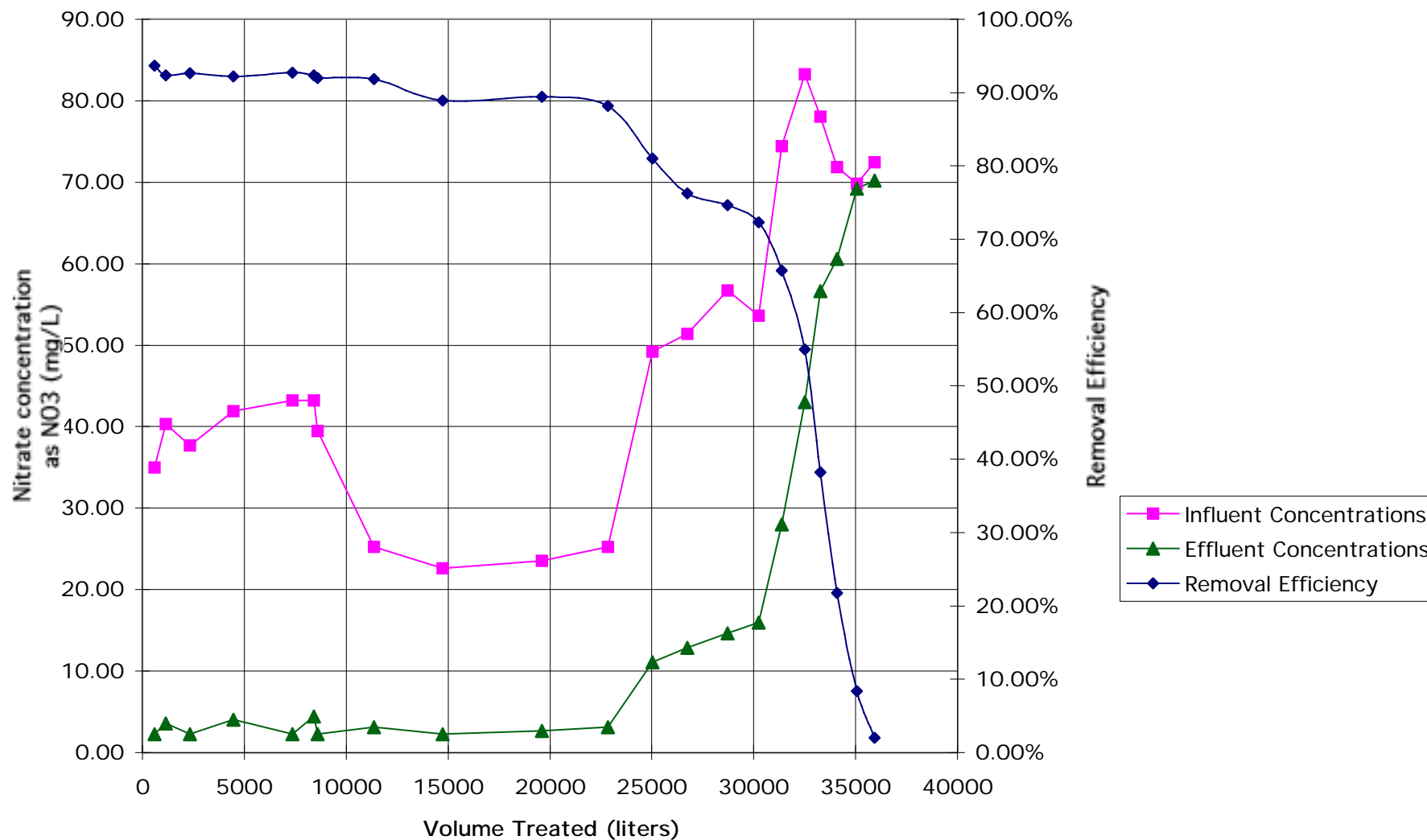

TRIAL A - Breakthrough Data

Nitrate values are from Hach kit readings, unless using spiked water when predicted value was used instead of Hach Data

	Total Flow (liters)	Influent NO3 Conc (mg/L)	Corrected Influent NO3 (mg/L)	Effluent NO3 Conc (mg/L)	Influent NO3 amount (g)	Effluent NO3 Amount (g)	Nitrate Removed (g)	Removal Efficiency
Batch #1	617	34.99	34.99	2.21	21.59	1.37	20.23	93.67%
1/21/99	1155	40.30	40.30	3.54	20.24	1.55	18.69	92.35%
	2335	37.64	37.64	2.21	46.01	3.40	42.61	92.61%
Batch #2	3305	41.85	41.85	3.99	38.53	3.01	35.53	92.20%
1/27/99	6196	43.18	43.18	2.21	122.91	8.96	113.95	92.71%
	7242	43.18	43.18	4.43	45.16	3.47	41.69	92.31%
	7442	39.41	39.41	2.21	8.26	0.66	7.60	91.96%
Batch #3	10185	25.24	25.24	3.10	88.68	7.29	81.39	91.78%
2/3/99	13576	22.59	22.59	2.21	81.09	9.01	72.08	88.89%
Batch #4	18434	23.47	23.47	2.66	111.87	11.83	100.04	89.42%
2/9/99	21678	25.24	25.24	3.10	79.01	9.34	69.68	88.18%
Batch #5	23861	49.16	171.00	11.07	214.20	15.47	198.73	92.78%
2/10/99	25565	51.37	171.00	12.84	291.38	20.37	271.01	93.01%
	27560	56.69	171.00	14.61	341.15	27.39	313.76	91.97%
	29081	53.59	171.00	15.94	260.09	23.24	236.85	91.07%
Batch #6	30198	74.40	185.00	28.00	198.83	24.54	174.28	87.66%
2/19/99	31333	83.20	185.00	43.00	209.98	40.29	169.68	80.81%
	32094	78.00	185.00	56.60	140.79	37.90	102.89	73.08%
	32920	71.80	185.00	60.60	152.81	48.40	104.41	68.32%
	33885	69.80	185.00	69.20	178.53	62.63	115.90	64.92%
	34754	72.40	185.00	70.20	160.77	60.57	100.20	62.32%

Average Influent Nitrate Concentration: 49.40
 Total Nitrate Removed (kg): 2.39
 Weighted Average Influent Concentration: 80.91
 Weighted Average Effluent Concentration: 12.10
 Total Liters Treated: 34754
 Total Gallons Treated: 9179

TRIAL A - Breakthrough Curve
Hach kit data, w/ estimated influent concentrations for spiked samples

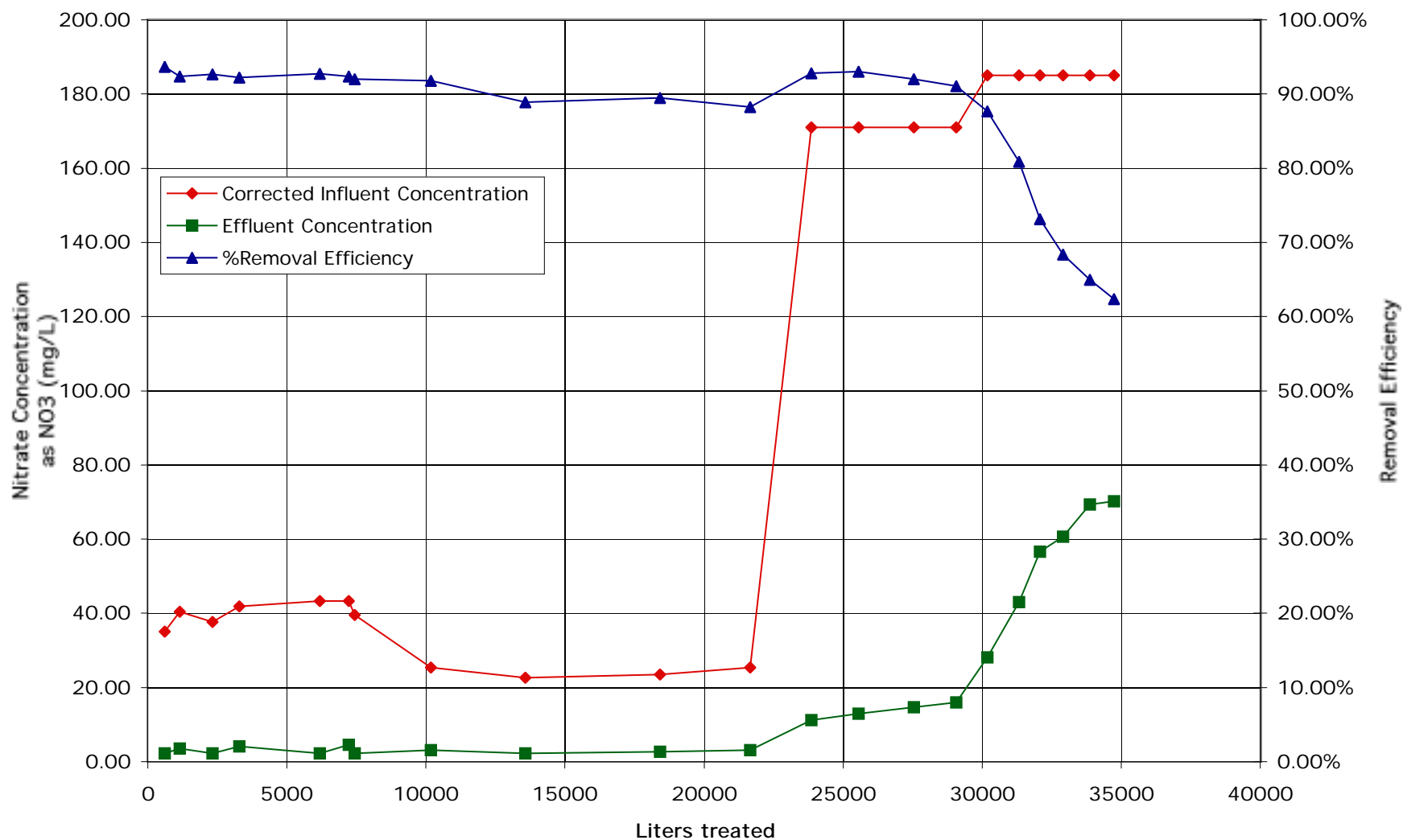

TRIAL A - Breakthrough Predictions

Sample calculations included in Appendix F

Using Hach Readings

Other Contaminants	ppm*	Conversion Factor	ppm, CaCO3
Bicarbonate, HCO3	370	0.82	303.4
Sulfate, SO4	53	1.04	55.12
Chloride, Cl	79	1.41	111.39

* Taken from Genmin analysis run on 12/18/98 (TF-834-EFLU-B111-1300)

Run #	Nitrate Conc (as NO3) ppm	Conversion Factor	ppm, CaCO3	grains/gal (as CaCO3)
1	41.27	0.81	33.43	1.95

Step 1 - Percent Nitrate

Percent Nitrate = (NO3 ppm as CaCO3)/(NO3 ppm as CaCO3 + SO4 ppm as CaCO3)

% NO3 = 0.38

Step 2 - Nitrate Leakage

Read from Figure #3 in Sybron literature (pg 3)

Salt regeneration level (lb salt/ft³ resin): 10

Nitrate Leakage as % of Influent Nitrate Level 30%

Nitrate Leakage (ppm as NO3): 6.84

Step 3 - Base Nitrate Capacity

Read from Figure #4

Base Capacity (grains/Ft³ NO3 (as CaCO3): 5000

Step 4 - Predicted Run Length

Actual Run Length = (Throughput)/(100%-%leakage)/100

Throughput = (Base Nitrate Capacity)/(Influent Load)

Predicted Run Length (gal/ft³) = 3,658

Predicted Run Length (gal) 9,144 based on flow to one column

Predicted Run Length (liter) 34,622

Using Spiking Prediction Values

Other Contaminants	ppm*	Conversion Factor	ppm, CaCO3
Bicarbonate, HCO ₃	370	0.82	303.4
Sulfate, SO ₄	53	1.04	55.12
Chloride, Cl	79	1.41	111.39

* Taken from Genmin analysis run on 12/18/98 (TF-834-EFLU-B111-1300)

Run #	Nitrate Conc (as NO ₃) ppm	Conversion Factor	ppm, CaCO ₃	grains/gal (as CaCO ₃)
1	80.91	0.81	65.54	3.83

Step 1 - Percent Nitrate

Percent Nitrate = (NO₃ ppm as CaCO₃)/(NO₃ ppm as CaCO₃ + SO₄ ppm as CaCO₃)

% NO₃ = 0.54

Step 2 - Nitrate Leakage

Read from Figure #3 in Sybron literature (pg 3)

Salt regeneration level (lb salt/ft³ resin): 10

Nitrate Leakage as % of Influent Nitrate Level 28%

Nitrate Leakage (ppm as NO₃): 12.52

Step 3 - Base Nitrate Capacity

Read from Figure #4

Base Capacity (grains/Ft³ NO₃ (as CaCO₃)): 5900

Step 4 - Predicted Run Length

Actual Run Length = (Throughput)/(100%-%leakage)/100

Throughput = (Base Nitrate Capacity)/(Influent Load)

Predicted Run Length (gal/ft³): 2,140

Predicted Run Length (gal) 5,351 based on flow to one column

Predicted Run Length (liter) 20,260

TRIAL A - Regeneration Data Sheets								
Regen#1 - aborted due to low flow rates of brine solution								
Initial Totalizer Reading	39474							
Time	9:45							
Final Totalizer Reading:								
	Time (on PLC) minutes	Length of Cycle minutes	Nitrate mg/L (as NO3)	Chloride mg/L	pH	Flow Rate lpm	Flow gpm	Total Flow liter
Backwash Cycle	8	10						
	4							
Brine Draw	51	56				1.2	0.32	
/Slow Rinse	46					1.15	0.30	
	36							
	26							
	16							
	6							
Rapid Rinse	3	6				4.35	1.15	
Brine Tank Fill		36						
Initial Brine tank level (in):	14							
Final brine tank level (in):	9							
Volume dispensed (gal):	35.76							

Regen#2 - Using Hach Kit data											
Initial Totalizer Reading (l)	57890										
Time	9:45										
Initial Pressure (psi)	35										
Initial Brine tank level (in):	14										
Level w/ Salt (in):	18.5										
Final Brine tank level:	3.3										
Final Totalizer reading:	58421										
New brine tank level:	26										
Feed nitrate concentration:	37.5										
	Time (on PLC) minutes	Length of Cycle minutes	Nitrate mg/L (as NO3)	Correct Nitrat Levels mg/l NO3	Chloride mg/L	Corrected Chloride levels (%)	pH	Flow Rate lpm	Flow rate gpm	Total Flow gal	Pressure psi
Backwash Cycle	8	10	49.1	47.87	1	0.10%	6.73	6.3	1.66	16.64	30
	4		35.9	34.67	1	0.10%	6.79		0		
Brine Draw /Slow Rinse	51	56	63.1	62	1	0.10%	6.81	2.63	0.69		35
	46		56.1	55	1	0.10%	6.81	2.70	0.71		
	36		4320	4295	20	2.00%	8.38	3.00	0.79		
	26		24700	24636	52	5.20%	8.15	2.70	0.71		
	16		17540	17456	68	6.80%	8.18				
	6		15240	15149	74	7.40%	8.18			40.77	
Rapid Rinse	3	6	10900	10807	76	7.60%	8.02	6.3	1.66	9.98	30
Brine Tank Fill		36									32
									Total:	67.39	gallons
Next time: get sample of brine for salinity reading....											

Trial A - Regeneration Data

Hach kit data

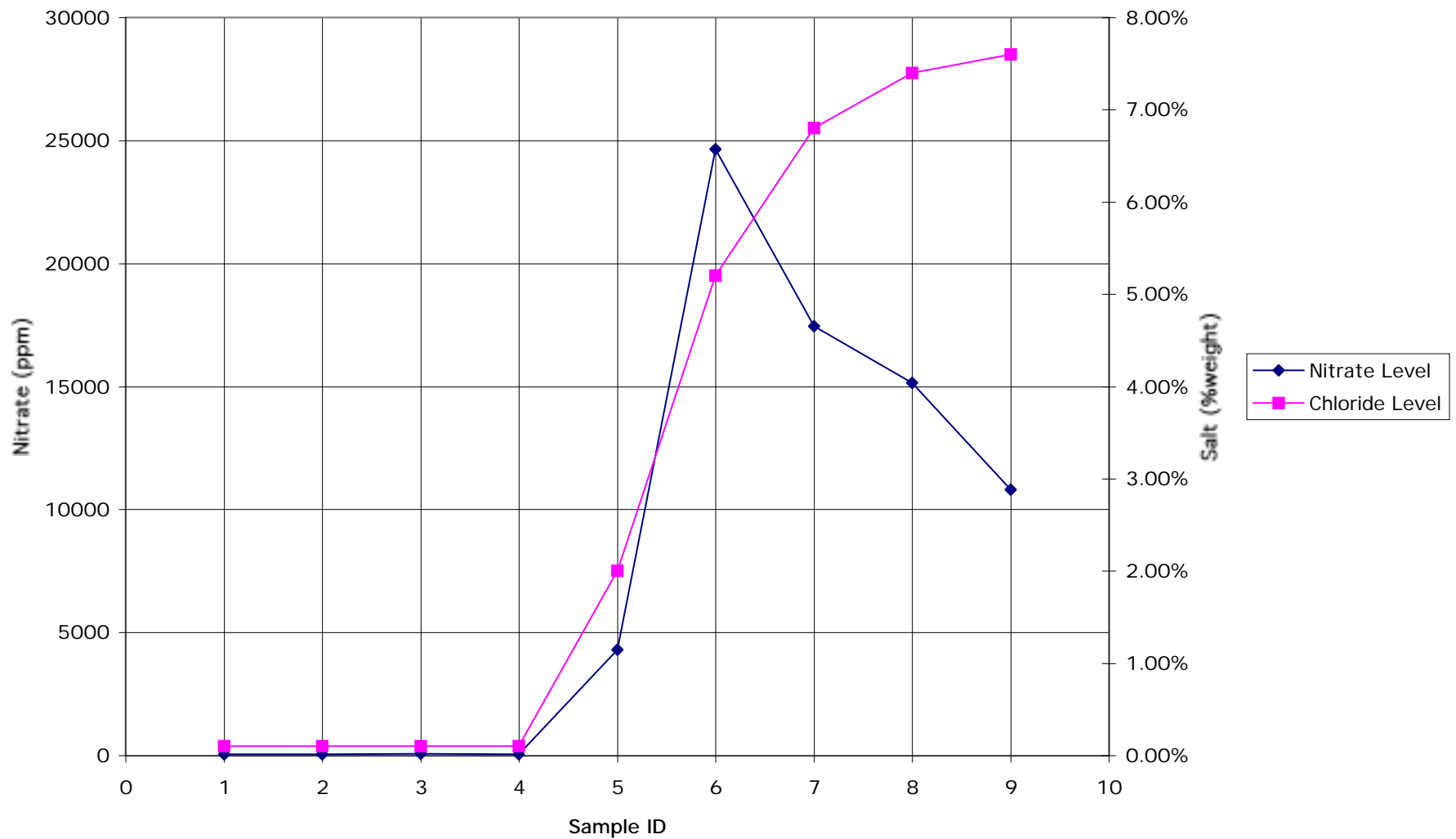

Graphical Integration of Chart								
Time	Nitrate	(mg/L)*min	mg					
10	55							
20	4295	21752	59954					
30	24636	144657	398711					
40	17456	210462	580086					
50	15149	163027	449342					
56	11928	81230	223889	end of brine draw cycle				
59	10807	34101	214837					
62	9216	30033	189209	end of rapid rinse				
82	176	93914	408660	clean water in brine tank fill				
		Min Removed	2	(not including predicted values)				
		Total kg	2.52					

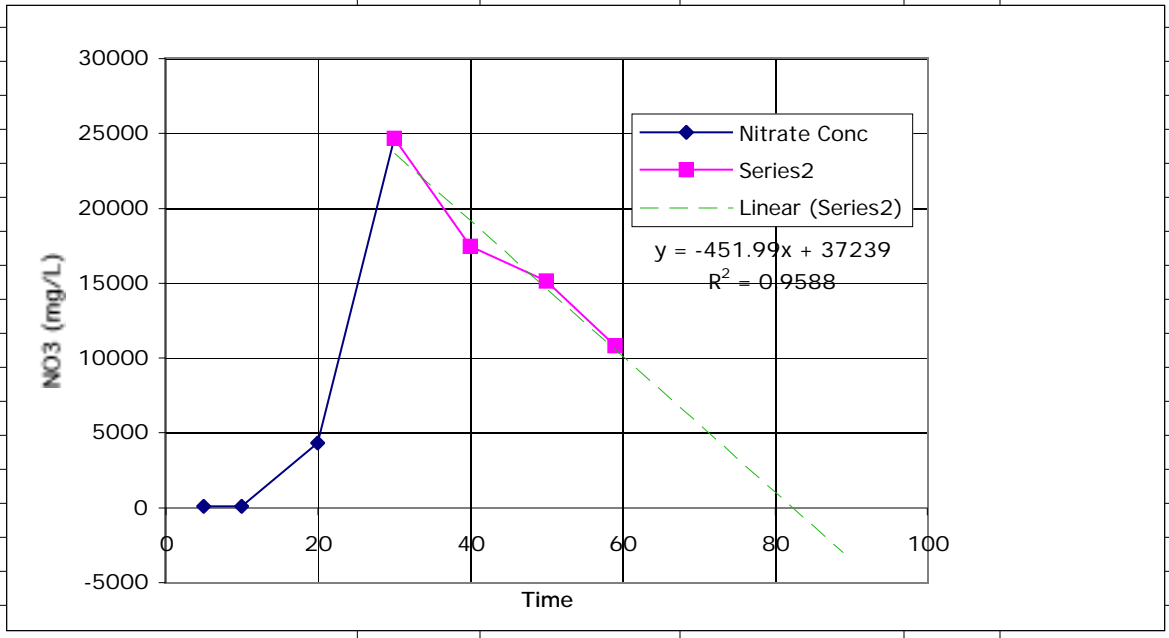

Trial B Data

TRIAL B - Breakthrough Curve Data

Unit run at 7.5 gpm (one column mode)

All samples analyzed by BC labs

	Flow Meter Reading (liters)	Total Flow (liters)	Total Flow (gallons)	Influent NO3 Conc (mg/L)	Effluent NO3 Conc (mg/L)	Influent NO3 amount (g)	Effluent NO3 Amount (g)	Nitrate Removed (g)	Removal Efficiency
4/9/99	64033	5533	1461	119.0	16.0	658.4	88.5	569.9	86.6%
4/14/99	64179	5679	1500	97.0	18.0	15.8	2.5	13.3	84.3%
	68726	10226	2701	95.0	19.0	436.5	84.1	352.4	80.7%
4/19/99	72687	14187	3747	102.0	51.0	390.2	138.6	251.5	64.5%
	73974	15474	4087	105.0	74.0	133.2	80.4	52.8	39.6%
	74807	16307	4307	103.0	86.0	86.6	66.6	20.0	23.1%
4/29/99	76778	18278	4827	77.0	80.0	177.4	163.6	13.8	7.8%
	79144	20644	5452	77.0	84.0	182.2	194.0	-11.8	-6.5%

Average Influent Nitrate Concentration (overall): 96.88

Weighted Average Influent Concentration (overall): 100.77

Weighted Average Effluent Concentration (before breakthrough): 17.13

Weighted Average Effluent Concentration (overall): 39.65

Weighted Average Removal Efficiency (before breakthrough): 83.9%

Liters Treated (overall): 20644

Liters Treated (before breakthrough): 10226

Gallons Treated (overall): 4827

Gallons Treated (before breakthrough): 2701

Total Nitrate Removed (kg): 1.27

% of water treated when breakthrough began: 55.9%

New water treated/waste ratio w/ regeneration modification 58.7

Trial B - Breakthrough Chart
7.5 gpm, one column operation

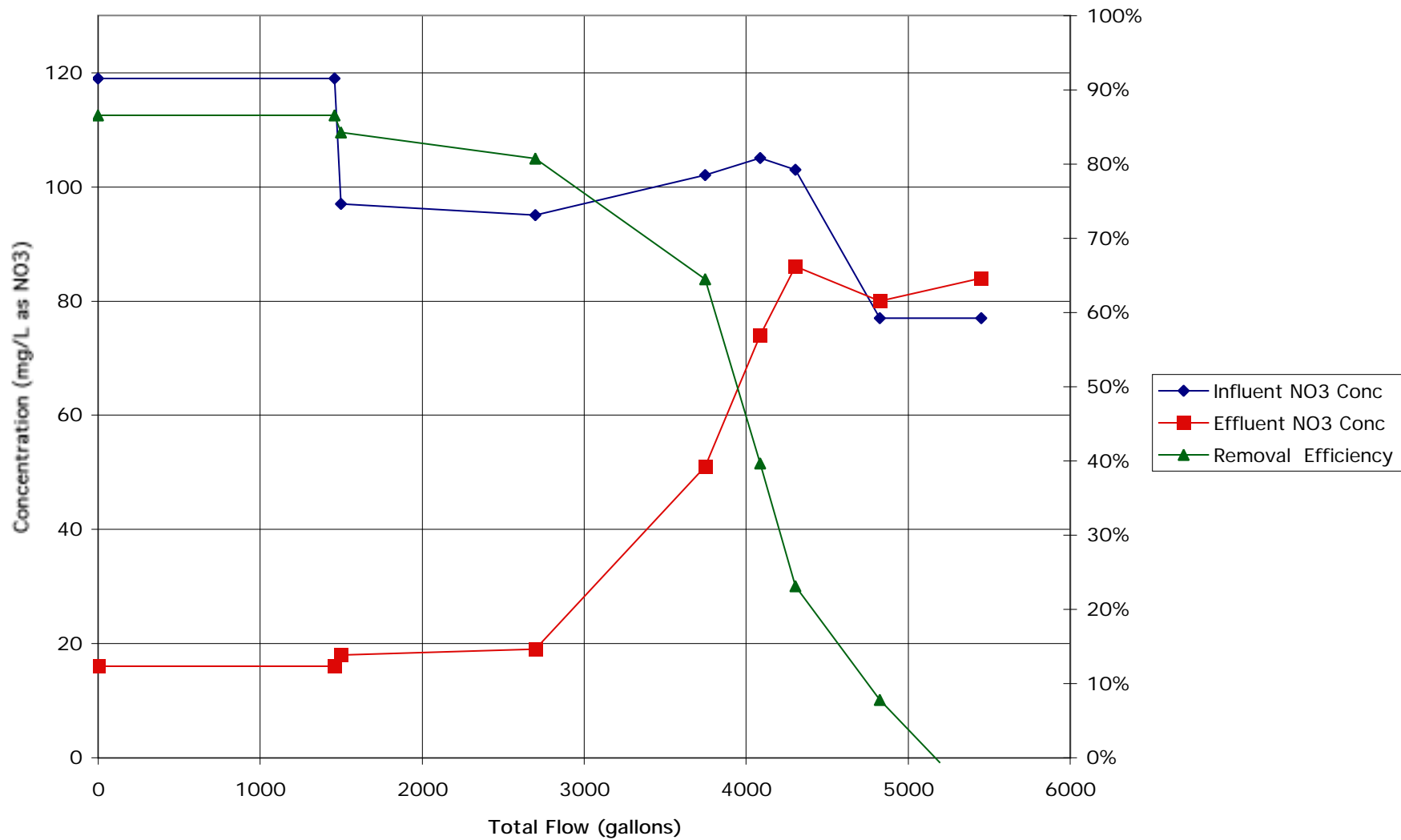

TRIAL B - Breakthrough Predictions

based on Sybron Literature predictions, see Appendix F For sample calcs

Other Contaminants	ppm*	Conversion Factor	ppm, CaCO3
Bicarbonate, HCO3	370	0.82	303.4
Sulfate, SO4	70	1.04	72.8
Chloride, Cl	79	1.41	111.39

* Taken from Genmin analysis run on 12/18/98 (TF-834-EFLU-B111-1300), A24778

Trial #	Nitrate Conc (as NO3) ppm	Conversion Factor	ppm, CaCO3	grains/gal (as CaCO3)
B	100.77	0.81	81.62	4.77

Step 1 - Percent Nitrate

Percent Nitrate = (NO3 ppm as CaCO3)/(NO3 ppm as CaCO3 + SO4 ppm as CaCO3)

% NO3 = 53%

Step 2 - Nitrate Leakage

Figure #3 in Sybron literature (pg 3)

Salt regeneration level (lb salt/ft³ resin): 10

Nitrate Leakage as % of Influent Nitrate Level 27%

Nitrate Leakage (ppm as NO3): 33.59

Step 3 - Base Nitrate Capacity

Read from Figure #4

Base Capacity (grains/ft³ (NO3 as CaCO3)) 6000

Step 4 - Predicted Run Length

Actual Run Length = (Throughput)/(100%-%leakage)/100

Throughput = (Base Capacity)/(Influent Load)

Predicted Run Length (gal/ft³) = 1,724

Predicted Run Length (gal) 4,309 Based on flow to only one column

Predicted Run Length (liter) 16,311 Based on flow to only one column

Comparison with actual Data:

% of actual gallons treated: 79.0%

% of actual leakage rate: 196.1%

TRIAL B - Regeneration Data Sheets

all data analyzed by BC labs, ZB156

Initial Totalizer Reading (l) 79393
 Time 8:38
 Initial Pressure (psi) 35
 Level w/ Salt (in): 12.5
 Final Brine tank level: 4.0
 Final Totalizer reading: 80348
 Feed nitrate concentration: 3.86 (estimate based on lowest nitrate reading)

	Time (from start) minutes	Time (on PLC) minutes	Time from start of regen cycle	Length of Cycle minutes	Sample ID	Pressure psi	Chloride Conc mg/L	Nitrate Conc mg/L as NO3	Flow Rate lpm	Total Nitrate grams	Total Chloride grams	Total Flow l	Total Flow gal
Backwash Cycle	4	6	4	10	LX167-OPTB-BW-6	35	45	64	6	1536	1080	24.00	6.34
	8	2	8		LX167-OPTB-BW-2		41	69	6	2484	1476	36.00	9.51
Brine Draw	5	195	15	200	LX167-OPTB-BDSR-195	30	43	77					
/Slow Rinse	10	190	20		LX167-OPTB-BDSR-190		45	83	2.78	2220	1221	27.75	7.33
	15	185	25		LX167-OPTB-BDSR-185		238	470					
	20	180	30		LX167-OPTB-BDSR-180		2430	2120					
	25	175	35		LX167-OPTB-BDSR-175		18000	10200	2.93	182258	436691	42.75	11.29
	30	170	40		LX167-OPTB-BDSR-170		33700	16100					
	35	165	45		LX167-OPTB-BDSR-165		37700	16400	2.63	394975	990675	27.75	7.33
	40	160	50		LX167-OPTB-BDSR-160		44500	14300	2.63	201469	539438	13.13	3.47
	45	155	55		LX167-OPTB-BDSR-155		49000	13100					
	50	150	60		LX167-OPTB-BDSR-150		50200	10600					
	55	145	65		LX167-OPTB-BDSR-145	35	50000	8820					
	60	140	70		LX167-OPTB-BDSR-140		26000	4480	2.55	530955	1966500	51.75	13.67
Rapid Rinse	2	4	72	6	LX167-OPTB-RR-4		798	141	6.45				
	4	2	76		LX167-OPTB-RR-2		542	91		4489	25929	38.70	10.22
Brine Tank Fill	6	10	82	20	LX167-OPTB-BTF-10		1400	54	0.65			13.00	3.43
	16	20	98		LX167-OPTB-BTF-20		879	59					

Total flow (minus brine tank fill): 261.83 69.15
 Nitrate removed(kg): 1.316 3.963

	Chloride (mg/L)	Nitrate (mg/L)	Waste Drum Volume (gal)	Liters	Nitrate removed (kg)
Drum #1 Sample LX167-OPTB-DRUM1	15500	5090	55	208.24	1.06
Drum #2 Sample LX167-OPTB-DRUM2	10900	1820	14.87	56.30	0.10
					1.16
Volume of samples:			0.72	2.72	

Summary	
Gallons waste produced:	69.15
kg Nitrate removed:	1.32
Regen removal efficiency:	103.4%
Gallons waste produced w/ modifications suggested	46.0
Reduction in waste %	33.5%

Note: Brine Tank Fill readings: Chloride levels inflated probably due to brine water in filter between resin tanks and brine tank

Trial B - Regeneration

BC labs data, using food grade salt

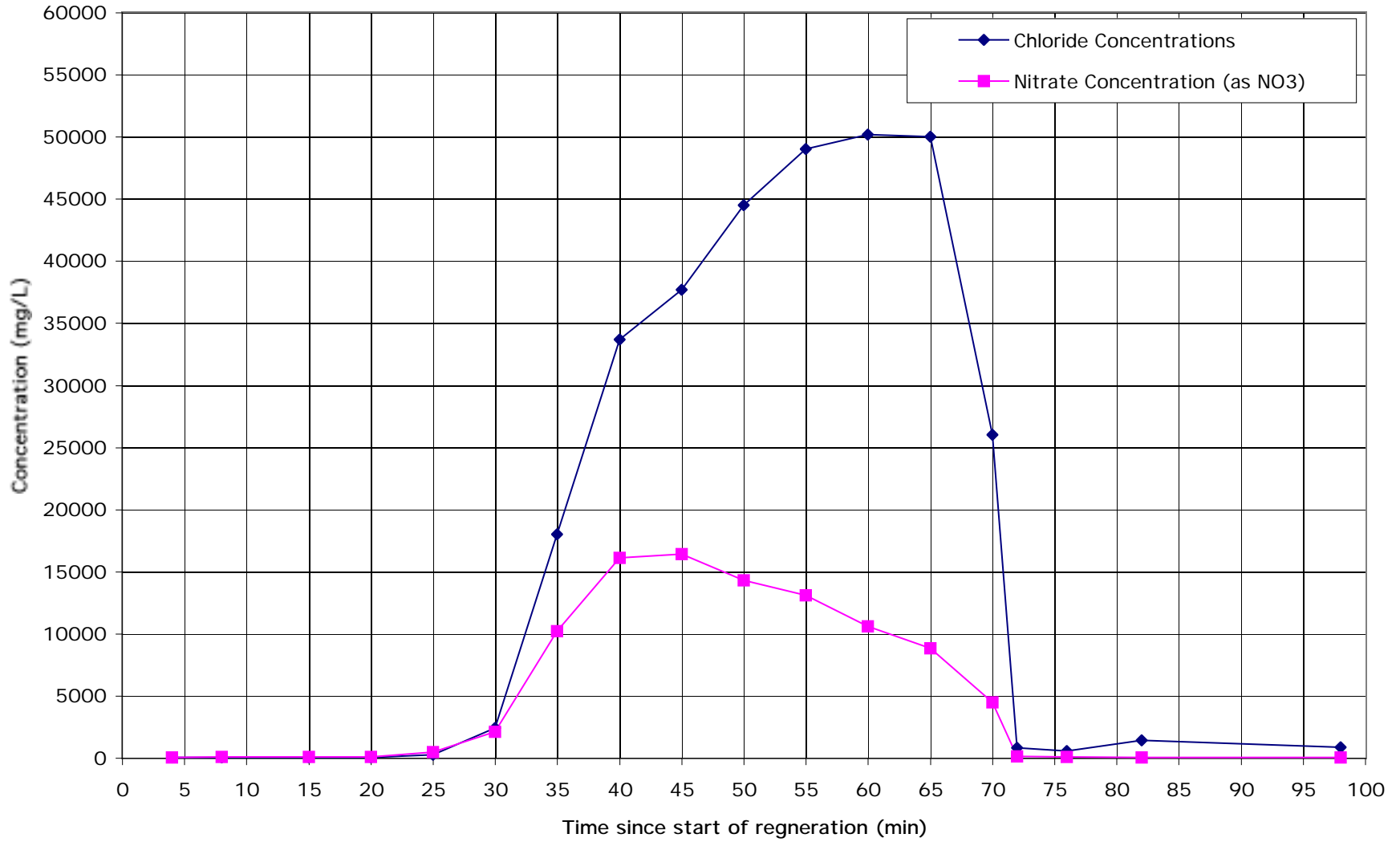

Trial C Data

TRIAL C - Breakthrough Curve Data

Unit run at 7.5 gpm (one column mode)

All samples analyzed by BC labs

	Flow Meter Reading (liters)	Total Flow (liters)	Total Flow (gallons)	Influent NO3 Conc (mg/L)	Effluent NO3 Conc (mg/L)	Influent NO3 amount (g)	Effluent NO3 Amount (g)	Nitrate Removed (g)	Removal Efficiency	
5/3/99	82366	1961	518	107.0	27.0	209.8	52.9	156.9	74.8%	
	85288	6600	1743	110.0	20.0	503.3	109.0	394.3	78.3%	
5/17/99	88180	7775	2053	99.0	20.0	122.8	23.5	99.3	80.9%	
	90801	10396	2746	102.0	24.0	263.4	57.7	205.7	78.1%	
5/24/99	94192	13787	3641	96.0	22.0	335.7	78.0	257.7	76.8%	
	96943	16538	4368	98.0	52.0	266.8	101.8	165.1	61.9%	Breakthrough Begins!
	98461	18056	4769	97.0	77.0	148.0	97.9	50.1	33.8%	
5/25/99	100028	19579	5171	85.0	100.0	138.6	134.8	3.8	2.7%	Breakthrough Ends!
	101776	21327	5633	85.0	105.0	148.6	179.2	-30.6	-20.6%	

Average Influent Nitrate Concentration (overall): 97.67

Weighted Average Influent Concentration (overall): 100.21

Weighted Average Effluent Concentration (before breakthrough): 23.29

Weighted Average Effluent Concentration (overall): 33.48

Weighted Average Removal Efficiency (before breakthrough): 77.6%

Liters Treated (overall): 19579

Liters Treated (before breakthrough): 13787

Gallons Treated (overall): 5171

Gallons Treated (before breakthrough): 3641

Total Nitrate Removed (kg): 1.33

% of water treated when breakthrough began: 70.4%

New water treated/waste ratio w/ regeneration modification 76.6

Trial C - Breakthrough Chart

7.5 gpm, one column operation

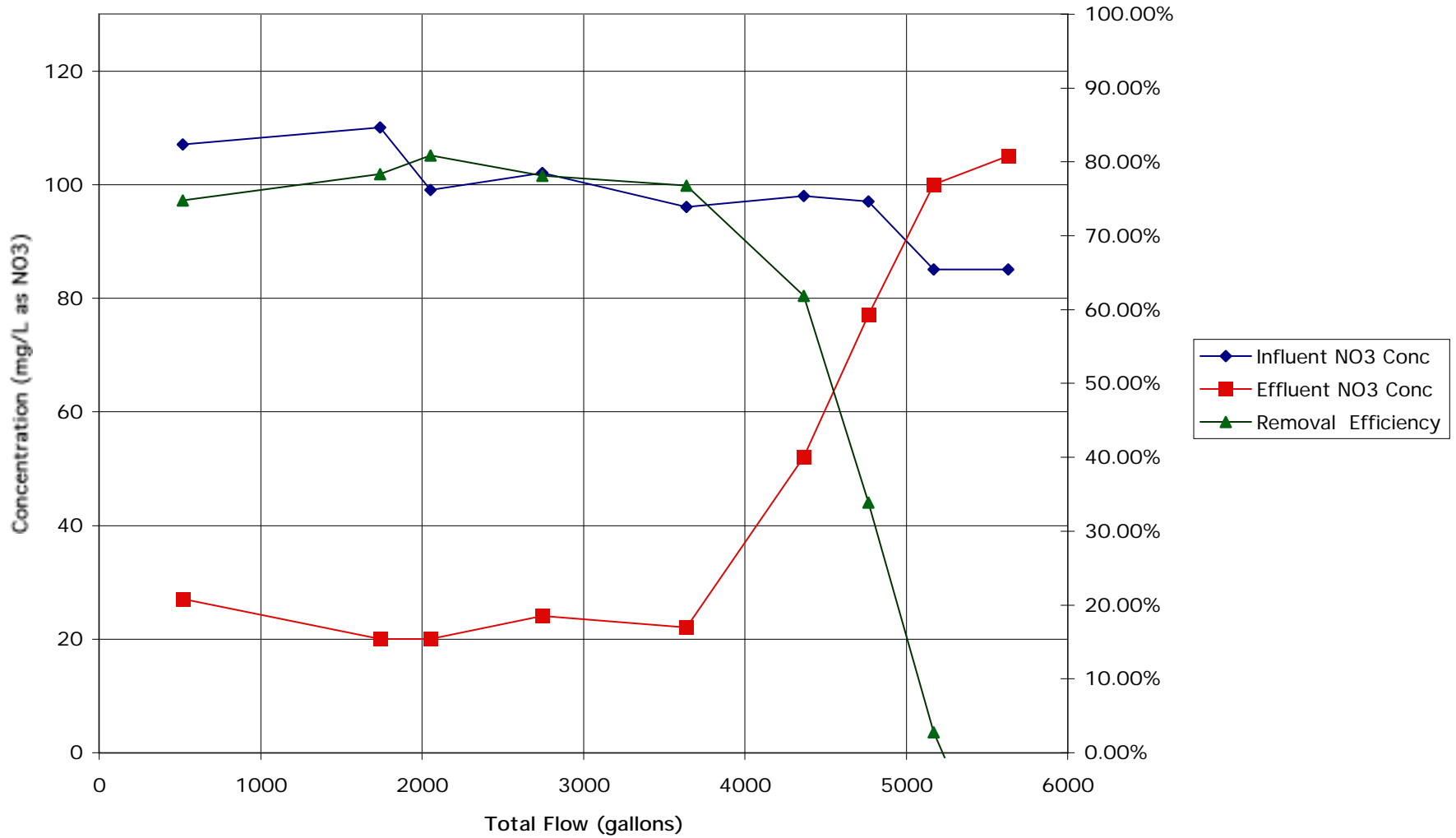

TRIAL C - Breakthrough Predictions

based on Sybron Literature predictions, see Appendix F For sample calcs

Other Contaminants	ppm*	Conversion Factor	ppm, CaCO3
Bicarbonate, HCO3	370	0.82	303.4
Sulfate, SO4	70	1.04	72.8
Chloride, Cl	79	1.41	111.39

* Taken from Genmin analysis run on 12/18/98 (TF-834-EFLU-B111-1300), A2478

Trial #	Nitrate Conc (as NO3) ppm	Conversion Factor	ppm, CaCO3	grains/gal (as CaCO3)
C	100.21	0.81	81.17	4.74

Step 1 - Percent Nitrate

Percent Nitrate = (NO3 ppm as CaCO3)/(NO3 ppm as CaCO3 + SO4 ppm as CaCO3)

% NO3 = 0.53

Step 2 - Nitrate Leakage

Read from Figure #3 in Sybron literature (pg 3)

Salt regeneration level (lb salt/ft³ resin): 10
 Nitrate Leakage as % of Influent Nitrate Level 27%
Nitrate Leakage (ppm as NO3): 33.40

Step 3 - Base Nitrate Capacity

Read from Figure #4

Base Capacity (grains/Ft³ (NO3 as CaCO3)) 6000

Step 4 - Predicted Run Length

Actual Run Length = (Throughput)/(100%-%leakage)/100

Throughput = (Base Nitrate Capacity)/(Influent Lo: Based on flow to one column

Predicted Run Length (gal/ft³) = 1,733
Predicted Run Length (gal) 4,334
Predicted Run Length (liter) 16,408

Comparison with actual Data:

% of actual gallons treated: 83.8%
 % of actual leakage rate: 143.4%

TRIAL C -Regeneration Data Sheets

all data analyzed by BC labs, ZB152

using Culligan Waster softener salt (solar salt)

Initial Totalizer Reading (l) 100972
 Time 6:45
 Initial Pressure (psi) 38
 Initial Brine tank level (in): 15
 Feed nitrate concentration: 58.00 mg/L
 Feed chloride conc: 47 mg/L

	Time (from start) minutes	Time (on PLC) minutes	Time from start of regen cycle	Length of Cycle minutes	Sample ID	Pressure psi	Flow Rate lpm	Chloride Level mg/L	Nitrate Level mg/L (as NO3)	Total Nitrate grams	Total Chloride grams	Total Flow liters	Total Flow gallons
Backwash Cycle	2	8	2	10	LX167-OPTC-BW-4	35	6.0	56	68				
(mislabelled)	6	4	6		LX167-OPTC-BW-8			49	59			60.0	15.8
Brine Draw	5	55	15	60	LX167-OPTC-BDSR-55			58	73				
/Slow Rinse	10	50	20		LX167-OPTC-BDSR-50	38	2.85	60	75			28.5	7.53
	15	45	25		LX167-OPTC-BDSR-45	38	3.00	265	355	3.14	2.38		
	20	40	30		LX167-OPTC-BDSR-40			2740	2060	17.66	21.97		
	25	35	35		LX167-OPTC-BDSR-35			21900	11600	66.59	120.12		
	30	30	40		LX167-OPTC-BDSR-30			38100	16700	137.96	292.50		
	35	25	45		LX167-OPTC-BDSR-25			47000	16300	160.88	414.86	103.1	27.2
	40	20	50		LX167-OPTC-BDSR-20		1.95	49100	14600	150.64	468.49		
	45	15	55		LX167-OPTC-BDSR-15			53100	13800	138.45	498.23		
	50	10	60		LX167-OPTC-BDSR-10		1.95	53600	12100	126.26	520.16		
	55	5	65		LX167-OPTC-BDSR-5			55700	10800	111.64	532.84		
	60	0	70		LX167-OPTC-BDSR-0			56500	9580	99.35	546.98	39.0	10.3
Rapid Rinse	2	4	72	6	LX167-OPTC-RR-4	32	6.3	55300	7230	105.90	704.34		
	4	2	76		LX167-OPTC-RR-2			41700	4760	151.07	1222.20	37.8	10.0
Brine Tank Fill	8	7	84	15	LX167-OPTC-BTF-10	35		859	54				
	14	1	98		LX167-OPTC-BTF-20			342	57				
									Sum	1.27	5.345	kg Salt	70.9
			Chloride (mg/L)	Nitrate (mg/l)	Drum Volume (liters)	Drum Vol (liters)	kgram nitrate				11.78	lb salt	
Drum #1 Sample	LX167-OPTC-DRUM1		18600	5620	208.24	208.24	1.17						
Drum #2 Sample	LX167-OPTC-DRUM2		24600	3390	69.41	69.41	0.24						
					Total:		1.41						
Summary													
										Gallons waste produced:	70.89		
										kg Nitrate removed:	1.27		
										Regen removal efficiency:	95.2%		
										Gallons waste produced w/ modifications suggested	47.5		
										Reduction in waste %	33.0%		

Trial C - Regeneration Chart

BC labs data, using solar salt

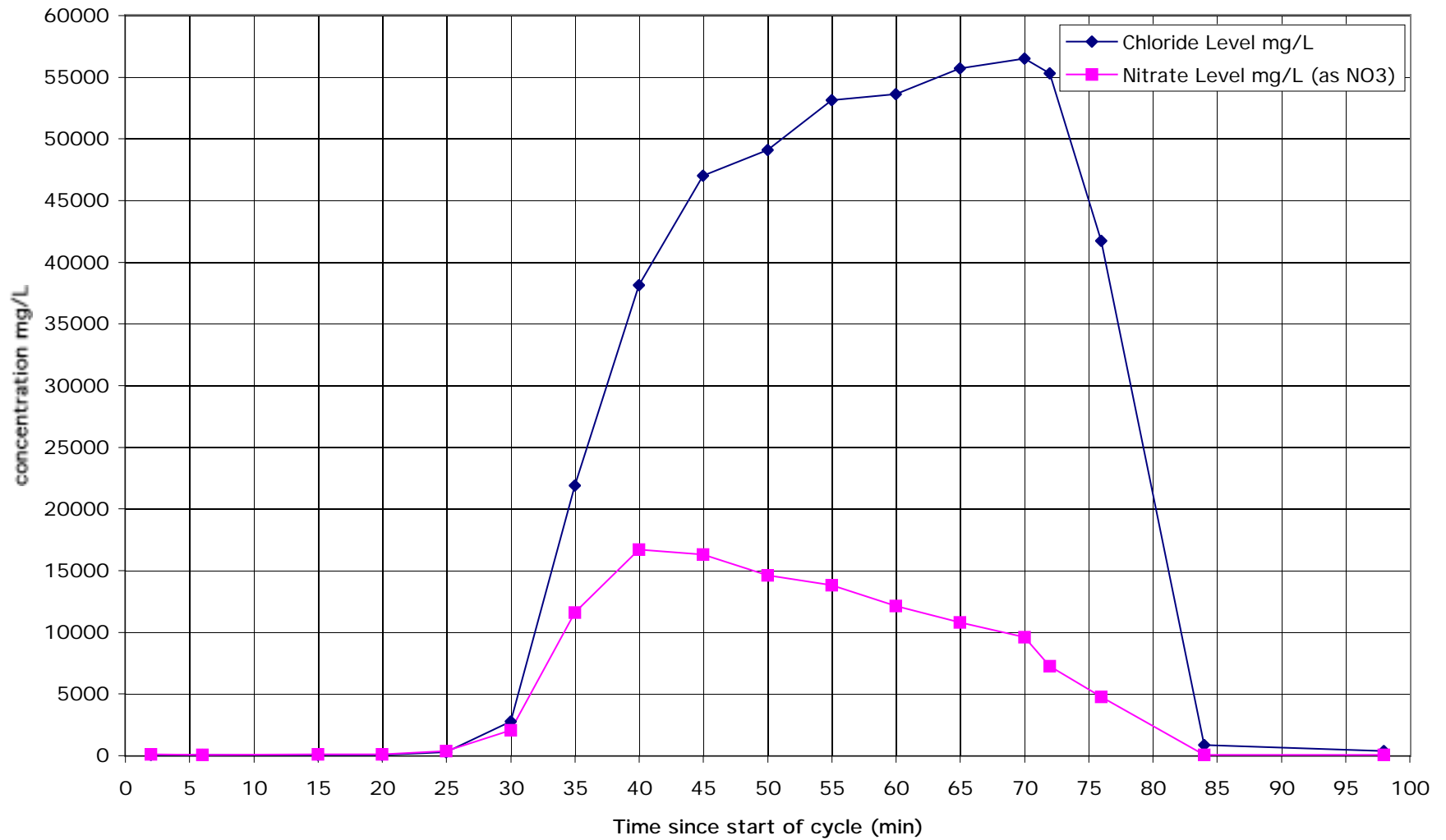

90 ppm Scenario Predictions

90 ppm - Breakthrough Predictions

based on Sybron Literature predictions, see Appendix F For sample calcs
Single Column Mode

Other Contaminants	ppm*	Conversion Factor	ppm, CaCO3
Bicarbonate, HCO3	370	0.82	303.4
Sulfate, SO4	70	1.04	72.8
Chloride, Cl	79	1.41	111.39

* Taken from Genmin analysis run on 12/18/98 (TF-834-EFLU-B111-1300), A2478

Trial #	Nitrate Conc (as NO3) ppm	Conversion Factor	ppm, CaCO3	grains/gal (as CaCO3)
Scenario	90.00	0.81	72.90	4.26

Step 1 - Percent Nitrate

Percent Nitrate = (NO3 ppm as CaCO3)/(NO3 ppm as CaCO3 + SO4 ppm as CaCO3)

% NO3 = 0.50

Step 2 - Nitrate Leakage

Read from Figure #3 in Sybron literature (pg 3)

Salt regeneration level (lb salt/ft3 resin): 10
 Nitrate Leakage as % of Influent Nitrate Level 27%
 Nitrate Leakage (ppm as NO3): 30.00

Step 3 - Base Nitrate Capacity

Read from Figure #4

Base Capacity (grains/Ft3 (NO3 as CaCO3)) 6000

Step 4 - Predicted Run Length

Actual Run Length = (Throughput)/(100%-%leakage)/100

Throughput = (Base Nitrate Capacity)/(Influent Load) Based on flow to one column

Predicted Run Length (gal/ft3) = 1,930
 Predicted Run Length (gal) 4,825
 Predicted Run Length (liter) 18,268

Compensation from Actual Data

Actual gallons until breakthrough 5884
 Actual gallons before breakthrough 3707
 Actual leakage rate 20

APPENDIX C

Hach Kit Data

Hach Test Kit Data

These tests were done with a Hach DR/890 Colorimeter test kit. High range nitrate Accuvac ampules were used. The minimum detection limit (MDL) is reported to be 2.2 mg/L as NO_3^- . The maximum detection limit is reported to be 132 mg/L as NO_3^- .

Summary of Method*

Cadmium metal reduces nitrates present in the sample to nitrite. The nitrite ion reacts in an acidic medium with sulfanilic acid to form an intermediate diazonium salt which couples to gentisic acid to form an amber-colored product.

Interferences*

Interfering Substances	Interference Levels and Treatment
Chloride	Chloride concentrations above 100 mg/L will cause Low results.
Ferric Iron	All levels
Nitrite	All Levels
pH	Highly buffered samples or extreme sample pH may exceed the buffering capacity of the reagents and require sample pretreatment.
Strong oxidizing and reducing substances	Interfere at all levels.

Tests Conducted

- Accuracy check against nitrate standards prepared with DI water.
- Comparison of BC labs data and Hach Kit samples (actual data from Ion Exchange Optimization Tests, Trial B)
- Comparison of Hach kit results over various dilutions of B834 water with DI water

Conclusions

Hach kit data is accurate when using DI water. There are appears to be a significant amount of interferences present in the water collected at B834. Hach kit results are, on the average, 45% below what BC labs report. BC labs use ion chromatography to collect their nitrate data.

*Summarized from the DR/890 Colorimeter Procedures Manual

Hach Kit Test Trials - Accuracy check with DI Water

Standards made using DI water, NaNO₃.

Accuvac Ampule method used

Results reported in mg/L as NO₃

Predicted	Chanda	Stephany
125	133.2	131.7
100	103.5	99.3
75	76.4	75.4
50	49.9	66.6
50	46.4	47.8
25	27.5	26.3
4.4	5.4	6.2
2.2	1	2.4

Possible error from letting filled ampule sit in solution for 20 seconds before shaking.

Hach Kit Accuracy Check

DI Water & NaNO₃ standard solution

Accuvac ampule method

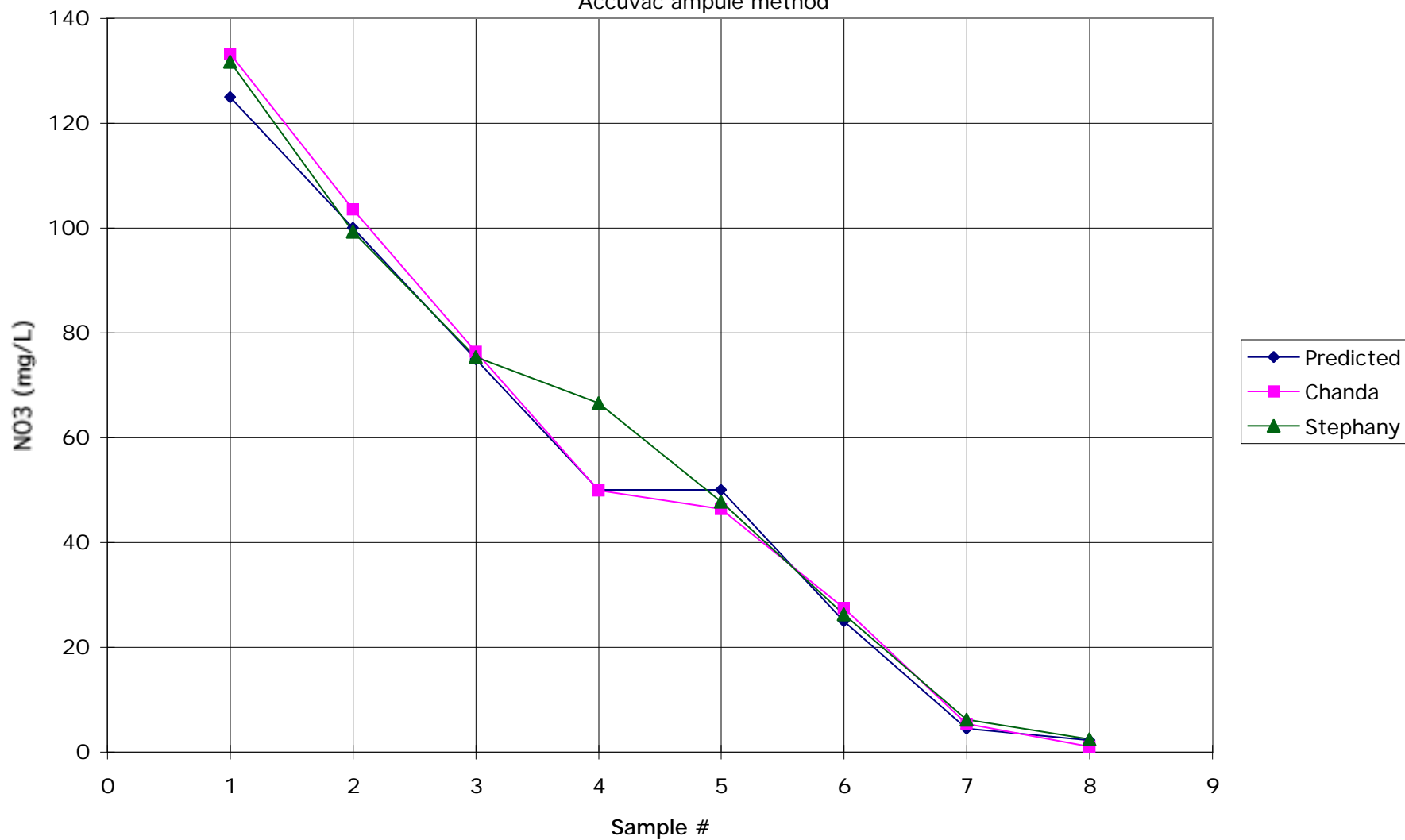

Hach Kit Test Trial - Data from Ion Exchange Optimization Study, Trial B

All data in mg/L as NO3

Sample #	BC	Hach	% Difference
1	16	19.6	18.37%
2	18	12.5	-44.00%
3	51	51.3	0.58%
4	74	49.5	-49.49%
5	77	48.5	-58.76%
6	77	53.4	-44.19%
7	80	51.1	-56.56%
8	84	48.3	-73.91%
9	97	57.7	-68.11%
10	102	75.8	-34.56%
11	105	61.4	-71.01%
12	119	77.7	-53.15%
		Average:	-44.57%

Hach Kit Accuracy Check
Data from IX Opt studies, Trial B
Accuvac ampule method

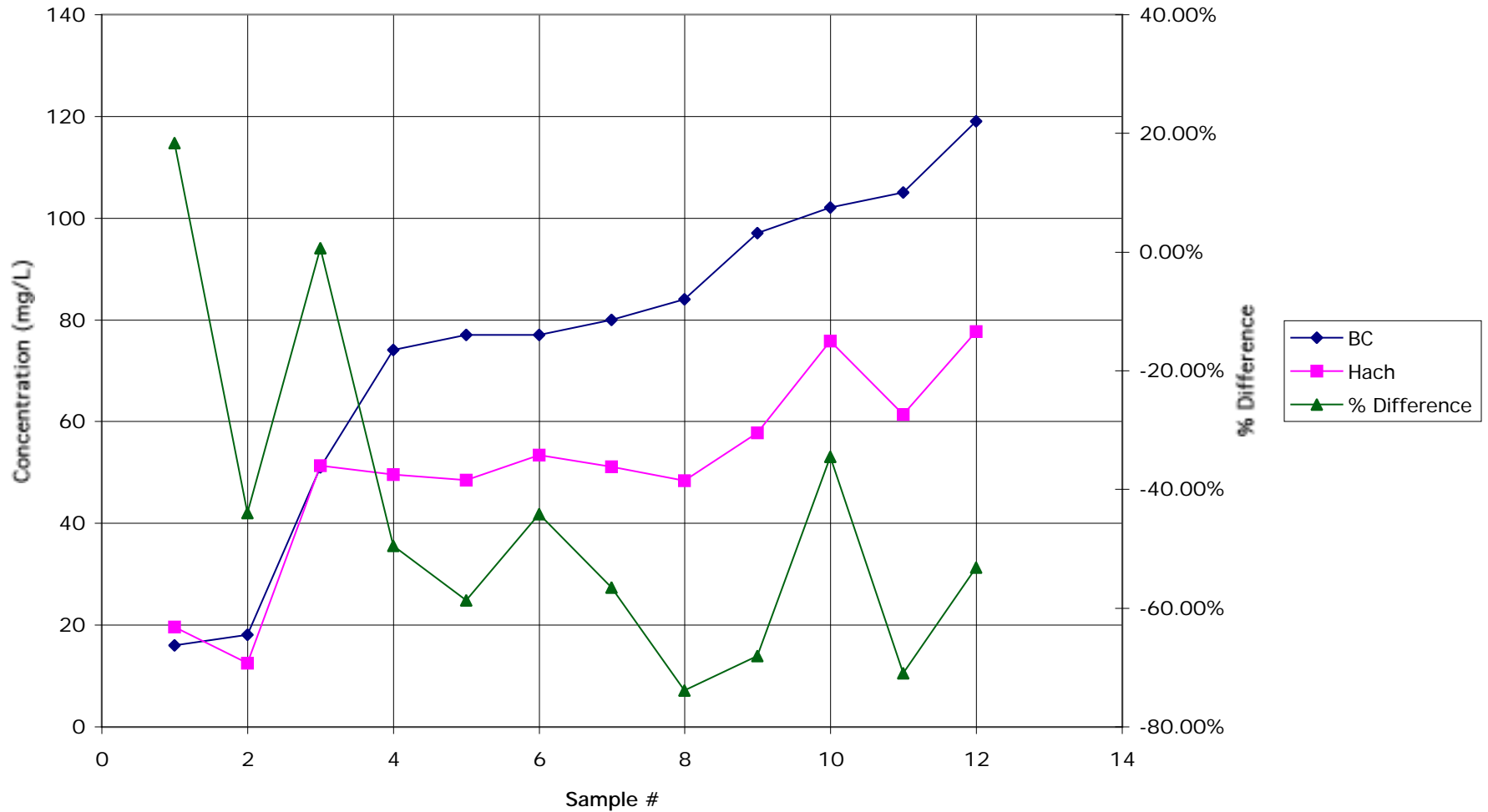

Hach Test Kit Trials - Different percentages of B834 water

Test Procedure

Take 3 liters B834 water, run through 3 inches ion exchange resin.

Test water for initial concentration of nitrates

Initial Concentration: Chanda: 0.8 Steph: 0.8 mg/L NO3

Desired Conc	Volume start	Add mg	Add mg	Extract
mg/L NO3	soln (ml)	NO3	NaNO3	ml
125	1000	125	171.37	100

Desired Conc	Volume start	Conc start soln	mg NO3	Total Volume	Add ml	Extract
mg/L NO3	soln (ml)	mg/l	have	final solution	DI water	(set aside)
100	250	125	31.25	313	63	100
50	213	100	21.30	426	213	242
25	184	50	9.20	368	184	192
10	176	25	4.40	440	264	410
5.0	30	10	0.30	60	30	60

Collected Data

% of B834 Water	Expected	Chanda	Stephany	Average	Difference	% Error
100%	125	71.7	73.1	72.4	52.6	42%
80%	100	66.4	71.8	69.1	30.9	31%
40%	50	40.7	42	41.35	8.65	17%
20%	25	23.4	25	24.2	0.8	3%
8%	10	10.9	10.4	10.65	-0.65	-7%

Hach Kit Accuracy Check
Concentration verses % of B834 water

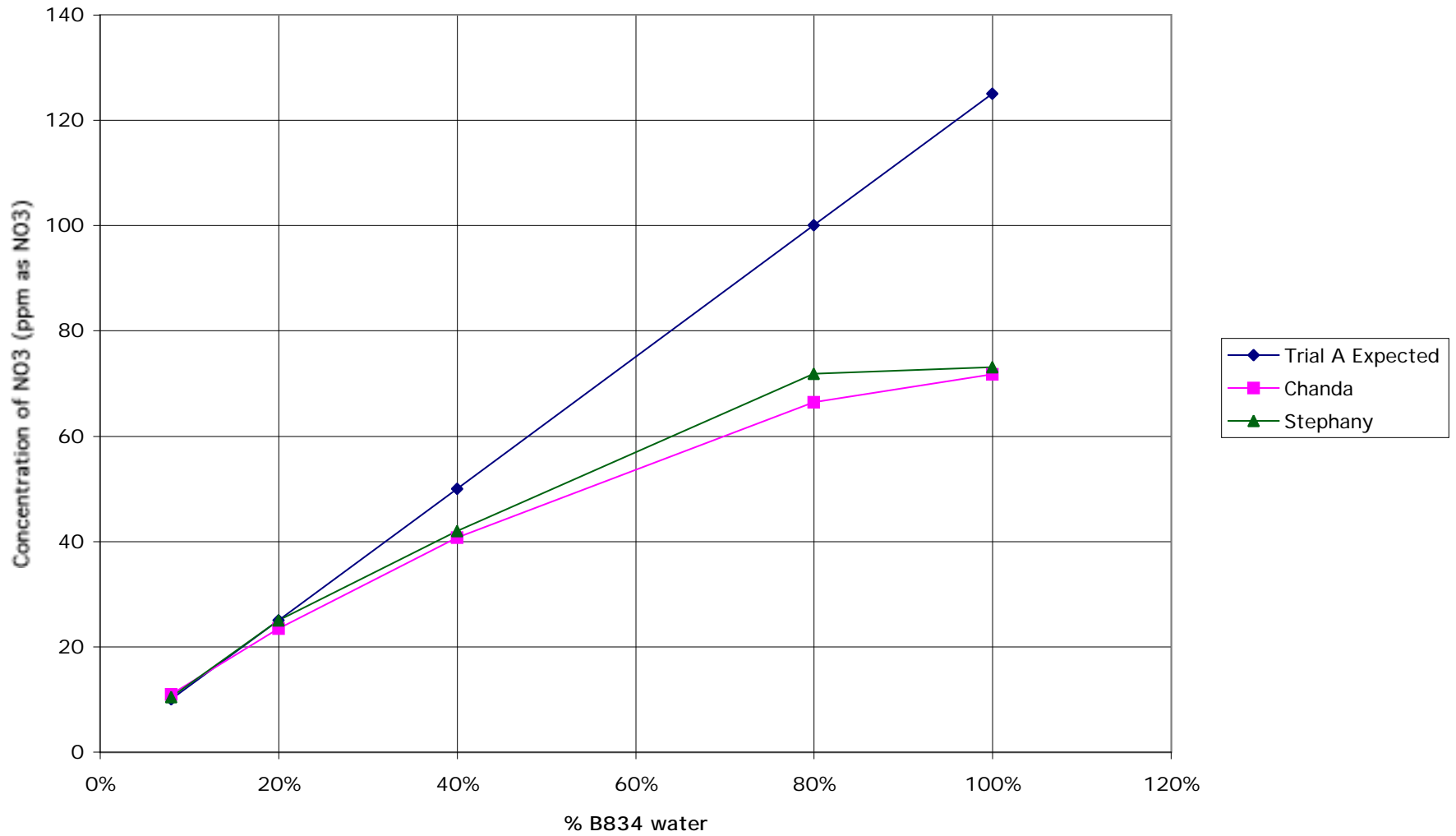

APPENDIX D

Perchlorate Tests & Predictions

**Removal of perchlorate with nitrate saturated Sybron SR-7 ion exchange resin
3X-046**

Stephany Burge

Experiment performed from 3/11/99 to 3/15/99

Analysis performed on 4/16/99

1.0 Summary

The purpose of this experiment was to determine whether or not perchlorate would be removed from groundwater with a nitrate saturated ion exchange resin. A quantity of Sybron SR-7 resin was placed in a jar of de-ionized (DI) water with a nitrate concentration of 300 mg/L (as NO_3^-). The resin and nitrate water were shaken for 24 hours. The resin was removed. A solution of DI water, with a 100mg/L nitrate and 130 $\mu\text{g/L}$ perchlorate, was prepared. The resin was placed in that solution and shaken for 24 hours. Perchlorate levels in the solution were analyzed before and after exposure to the resin. The before concentration was 130 $\mu\text{g/L}$. The after concentration of perchlorate non-detectable. In conclusion, a nitrate saturated Sybron SR-7 will still preferentially remove perchlorates.

This is also suggested in the paper "Application of Ion-Exchange Technology for Perchlorate Removal from San Gabriel Basin Groundwater" by Montgomery Watson. The goal of their study was to determine a resin suitable for removing perchlorate via ion exchange. They tested two polystyrene based resins (similar to the SR-7 resin) and one polyacrylic resin. During testing, nitrate always broke through long before perchlorate for all of the resins. Perchlorate was also very difficult to remove from both of the polystyrene resins during regeneration.

2.0 Methods

This method will be repeated twice. Trial A and Trial B will be analyzed concurrently.

Step #1 – Calculation of desired solutions

	Quantity	Concentration*	meq/L	meq Total
Sybron SR-7 Resin	0.5 grams per trial	2.2 meq/gram		1.1 meq
Nitrate (NO_3^-) Starting Solution	0.5 Liters	300 mg/L	300	150 meq

(Solution A)				
Nitrate in Solution B	0.5 Liters	100 mg/L	100	50 meq
Perchlorate (ClO_4^-) in Solution B	0.5 Liters	130 $\mu\text{g/L}$	0.130	0.065 meq

* The meq/L of perchlorate and nitrate is equal to the concentration in mg/L.

Step #2 – Preparation of Solutions

The nitrate starting solution (Solution A) was prepared by dissolving 0.412 grams of NaNO_3 (or 300 grams of NO_3^-) in 1 liter of deionized water. The solution was mixed for several minutes.

The nitrate/perchlorate solution (Solution B) was prepared by dissolving nitrate and perchlorate in DI water. A starting solution of perchlorate in DI water was used. The starting concentration of that solution was thought to be $432\mu\text{g/L}$. 230 ml of the perchlorate starting solution was added to 970 ml of DI water. The intent was to increase the perchlorate concentration in Solution B to $50\mu\text{g/L}$. Unfortunately, the starting solution was much higher than expected. According to lab analysis, the final concentration of Solution B was $130\mu\text{g/L}$. 0.274 grams of NaNO_3 (or 0.206 grams of NO_3^-) were added. Using the Hach Colorimeter 890 test kit, the nitrate concentration was measured to be 105.4 mg/L NO_3^- .

Step #2 Saturation of resin with Solution A.

Two 500 ml jars were selected. 0.5 grams of resin were placed in each jar. 500 ml of Solution A was placed in each jar. The jars were sealed and placed on a shaker for 24 hours. The resin was removed by filtering from Solution A.

Step #3 Exposure to Solution B

The 500 ml jars were rinsed with DI water. The resin was placed back into the jars. 500 ml of Solution B was added to each jar. The jars were again placed on the shaker. They were allowed to continue shaking for 24 hours. The resin was again filtered out of the remaining solutions. Samples of Solution B before and after exposure to the resin were sent to CalTest labs for analysis.

3.0 Results

CalTest labs reported an initial concentration of perchlorates in Solution B to be 130 $\mu\text{g/L}$. For both trials, the concentration of the solution after exposure to perchlorate was non-detectable.

Data logged in ZB148
at LOC a23150

**Perchlorate removal with Sybron SR-7 ion exchange resin
LX-168**

Stephany Burge, Gene Kumamoto

Experiment performed on October 23, 1998
Analysis performed on November 9, 1998

Purpose:

A preliminary test was conducted to determine whether or not Sybron SR-7 resin will remove perchlorates from the ground water at Site 300. Four liters of perchlorate spiked well water were poured through a test stand column filled with resin. Samples were collected from the influent and effluent streams. The samples will be analyzed for perchlorates levels.

Test Procedure:

0.00158 g of potassium perchlorate were dissolved in 1 liter of DI water. 250 ml were transferred into another flask. That water was added to 3.75 liters of water from well #830-19 (Site 300). The estimated concentration of perchlorate is 50 ppb.

A test column at TFC was set up on the test stand. The column was filled with approximately 45.95 inches³ of Sybron SR-7 resin. The resin was rinsed in DI water and allowed to settle.

A dip sample of the spiked perchlorate water was taken at 10:00 am. The perchlorate solution was slowly poured into the column. Effluent samples were taken when 2 and 3.5 liters of water had passed through the column (at 10:05 am and 10:15 am, respectively). The samples were sent to CLS for analysis.

Results:

According to lab analysis, the influent perchlorate concentration was 27 ppb. Both effluent concentrations were non-detectable. In conclusion, Sybron SR-7 resin will selectively remove perchlorates from groundwater.

*Some water as used in Nolle Serrano's tests
from well #830-10
measured concentration = ~58 mg/L*

orig. concentration

$$\frac{27 \text{ mg}}{\text{L}} \times 4.00 \text{ L} = \frac{108 \text{ mg}}{0.250 \text{ L}} = 432 \text{ mg/L}$$

original conc:

$$.00158 \text{ g KClO}_4 \left| \frac{100 \text{ ClO}_4}{140 \text{ KClO}_4} \right| = \frac{1.129 \text{ mg ClO}_4}{1 \text{ L}} \text{ or } 1129 \text{ ppb}$$

test
$$.250 \text{ L} \times \left| \frac{1.129 \text{ mg ClO}_4}{1 \text{ L}} \right| = \frac{0.282 \text{ mg ClO}_4}{4 \text{ L}} = 70 \text{ ppb}$$

predicted final conc

Sybron suggested flow

2.0 \rightarrow 5.0 gpm / ft³ resin

have 46 inche³ resin or 26.6×10^{-3} ft³ resin

Max flow \rightarrow 0.133 gpm

min flow \rightarrow 0.053 gpm

Flow of unit

15 minutes, 3.5 liters \rightarrow 0.616 gallons /
minute

little bit above minimum flow! 16-20%
above min flow.

D
10 gpm

CLS Labs

Analysis Report: Perchlorate, EPA Method 300.0
Analysis Code: E300.0

Client: Lawrence Livermore Natl. Lab
University of California
7000 East Ave./P.O. Box 808
Livermore, Ca 94551

Project No.: A23994
Contact: ERD Data Management
Team L-528
Phone: () -

Project: Perchlorate Removal

Date Sampled: 10/23/98
Date Received: 10/23/98
Date Extracted: N/A
Date Analyzed: 10/26/98
Date Reported: 11/05/98

THIS IS REALLY:
ILL-EXP-168

Lab Contact: George Hampton
Lab ID No.: P7716
Job No.: 817716
COC Log No.: CEA008
Batch No.: IC1981026
Instrument ID: IC101
Analyst ID: PONGC
Matrix: AQ

ANALYTICAL RESULTS

Lab / Client ID Analyte	Code	Results (ug/L)	Rep. Limit (ug/L)	Dilution (factor)	Date Analyzed
1A / LX168-Effluent1 Perchlorate	6415	ND	4.0	1.0	10/26/98
2A / LX168-Effluent2 Perchlorate	6415	ND	4.0	1.0	10/26/98
3A / LX168-inf Perchlorate	6415	27	4.0	1.0	10/26/98

ND - Not detected at or above indicated Reporting Limit

Perchlorate - Breakthrough Predictions

based on Sybron Literature predictions, see Appendix F For sample calcs

Other Contaminants	ppm*	Conversion Factor	ppm, CaCO3
Bicarbonate, H	370	0.82	303.4
Sulfate, SO4	70	1.04	72.8
Chloride, Cl	79	1.41	111.39

* Taken from Genmin analysis run on 12/18/98 (TF-834-EFLU-B111-1300), A24778

Trial #	Perc Conc (as NO3) ppm	Conversion Factor	ppm, CaCO3	grains/gal (as CaCO3)
Any	0.040	1.00	0.040	0.0023

Step 1 - Percent Perchlorate

Percent Perchlorate = (Perc ppm as CaCO3)/(Perc ppm as CaCO3 + SO4 ppm as CaCO3)

% NO3 = 0.055%

Step 2 - Perchlorate Leakage

Figure #3 in Sybron literature (pg 3)

Salt regeneration level (lb salt/ft3 resin): 10

Perchlorate Leakage as % of Influent Perc Level 45% ??? Could also be 0?

Perchlorate Leakage (ppm as ClO4): 0.0180

Step 3 - Base Capacity

Read from Figure #4

Base Capacity (grains/ft3 (Perc as CaCO3)) 2000

Step 4 - Predicted Run Length

Actual Run Length = (Throughput)/(100%-%leakage)/100

Throughput = (Base Capacity)/(Influent Load)

Predicted Run Length (gal/ft: 1,556,182

Predicted Run Length (gal) 11,443,383 Based on flow to 55 gallon drum

Predicted Run Length (liter) 43,313,205 Based on flow to 55 gallon drum

Including extra predictor fact: 9,303,470

Breaking off at: 5,879,793

Years 3.20 at 3.5 gpm flow rate

APPENDIX E

Cost Analysis

Ion Exchange Cost breakdown					
Yearly basis, based on 1999 prices					
Option 1: Nitrate only removal - Dual Column Mode					
Setup/Installation					
	<i>Item</i>	<i>Quantity</i>	<i>Cost per Unit</i>	<i>Total</i>	<i>Notes</i>
	<u>Procure Equipment</u>				
	1,000 gallon influent storage tank	1	\$1,300	\$1,300	Estimate from Ryan Process, Danville 8/13/99
	15 gpm pump (1 to 2 hp)	1	\$600	\$600	Estimate from George Metzger 7/13/99
	Motor starter, floating switch, controls	1	\$3,000	\$3,000	Estimate from George Metzger 7/13/99
	Ion exchange unit	1	\$10,000	\$10,000	Based on cost of 15gpm Krudico unit already purchased
	Regeneration waste storage tank, 500 gallon salt resistant tank	1	\$800	\$800	Estimate from Ryan Process, Danville 8/13/99
	<u>Mobilization to Site</u>				
	Move ion exchange unit to actual site	1 tech, 1 day	\$60/hr	\$480	Technician rates from Dick Woodward 8/16/99
	Clean water flush	1 tech, 3 days	\$60/hr	\$1,440	
	<u>Controls and Interlocks</u>				
	Senior technician	1 week, LLNL 300	\$82/hr	\$4,592	
	Technician	1 week, LLNL 500	\$60/hr	\$3,360	
	Total Setup/Installation Costs			\$25,572	
Operations and Maintenance					
	<u>Control/Instrumentation Calib/Maintenance</u>				
	Technician	1/2 day, month	\$60/hr	\$2,880	
	<u>Mechanical O & M</u>				
	Facility Operator	500 hrs/year	\$60/hr	\$30,000	Includes informational sampling, 25% of their time
	<u>Consumables</u>				
	Solar salt (50 lb bag/ 7,000 gallons treated water)	124	\$5	\$643	\$5.17 if buying 850lbs plus from Culligan Water Supply
	Replacement Sybron SR-7 Resin (ft3)	2.5	\$280	\$700	\$280/cu ft, 2.5 cu ft/column (since bi-annual replacement, only half cost reflected here)
	Electricity costs	3267	\$0.10/kwhr	\$327	Based on 2 hp pump, operating for 25% of the time, Dick Woodward 8/16/99
	Disposal of regeneration waste (cost per 55 gallon drum)	316	\$700	\$221,475	\$700/drum including administrative costs, Rob Tagesson 7/28/99
	<u>Facility Documentation and Data Collection</u>				
	E300:00 Nitrate samples	24	\$10	\$240	BC labs, \$10 for 20d TAT, once month for influent and effluent
	Data management time	24	\$37.50/analysis	\$900	
	Nitrate Test kit	1	\$1,200	\$1,200	Includes enough ampules for influent/effluent sample every working day, 1 yr
	Total Operations and Maintenance Costs (per year)			\$258,365	
	Gallons treated per year (3.5gpm)			1,839,600	
	Kg nitrate removed per year (3.5 gpm)			44	
	Cost per gallon (overall)			\$0.15	
	Cost per gallon (yearly O&M)			\$0.14	
	Cost per kg treated (overall)			\$6,491	
	Cost per kg treated (yearly O&M)			\$5,907	

Option 2: Perchlorate removal					
Setup/Installation					
	<i>Item</i>	<i>Quantity</i>	<i>Cost per Unit</i>	<i>Total</i>	<i>Notes</i>
	<u>Procure Equipment</u>				
	55 gallon drum container	1	\$200	\$200	
	Resin (ft3)	7.4	\$280	\$2,059	
	Flow distributor	1	\$100	\$100	
	<u>Mobilization to Site</u>				
	Move ion exchange unit to actual site	1 tech, 1 day	\$60/hr	\$480	
	Clean water flush	1 tech, 3 days	\$60/hr	\$1,440	
	Total Setup/Installation Costs			\$4,279	
Operations and Maintenance					
	<u>Control/Instrumentation Calib/Maintenance</u>				
	Technical	1 hr per week	\$60/hr	\$3,120	
	<u>Mechanical O & M</u>				
	Facility Operator	500 hrs/year	\$60/hr	\$30,000	5% of their time
	Consumables				
	Replacement Sybron SR-7 Resin	3.675	\$280	\$1,029	Replace resin at max of every 3 years, calcs based on every two years
	Disposal of resin	0.5	\$700	\$350	
	<u>Facility Documentation and Data Collection</u>				
	Perchlorate Samples	24	\$110	\$2,640	
	Data management time	24	\$37.50/analysis	\$75	
	Total Operations and Maintenance Costs (per year)			\$37,214	
	Gallons treated per year (3.5gpm)			1,839,600	
	Kg perchlorate removed per year			0.019	
	Cost per gallon (overall)			\$0.02	
	Cost per gallon (yearly O&M)			\$0.02	
	Cost per kg perchlorate treated (overall)			\$2,134,293	
	Cost per kg perchlorate treated (O&M)			\$1,914,207	

Option 3: Nitrate and Perchlorate removal					
Setup/Installation					
	<i>Item</i>	<i>Quantity</i>	<i>Cost per Unit</i>	<i>Total</i>	<i>Notes</i>
	<u>Procure Equipment</u>				
	1,000 gallon influent storage tank	1	\$1,300	\$1,300	Estimate from Ryan Process, Danville 8/13/99
	15 gpm pump (1 to 2 HP)	1	\$600	\$600	Estimate from George Metzger 7/13/99
	Motor starter, floating switch, controls	1	\$3,000	\$3,000	Estimate from George Metzger 7/13/99
	Ion exchange unit	1	\$12,000	\$12,000	Based on cost of 15gpm Krudico unit already purchased, includes 3rd resin tank for perchlorate removal
	Regeneration waste storage tank, 500 gallon salt resistant tank	1	\$800	\$800	Estimate from Ryan Process, Danville 8/13/99
	<u>Mobilization to Site</u>				
	Move ion exchange unit to actual site	1 tech, 1 day	\$60/hr	\$480	Technician rates from Dick Woodward 8/16/99
	Clean water flush	1 tech, 3 days	\$60/hr	\$1,440	
	<u>Controls and Interlocks</u>				
	Senior technician	1 week, LLNL 300	\$82/hr	\$4,592	
	Technician	1 week, LLNL 500	\$60/hr	\$3,360	
	Total Setup/Installation Costs			\$27,572	
Operations and Maintenance					
	<u>Control/Instrumentation Calib/Maintenance</u>				
	Technician	1/2 day, month	\$60/hr	\$2,880	
	<u>Mechanical O & M</u>				
	Facility Operator	500 hrs/year	\$60/hr	\$30,000	Includes informational sampling, 25% of their time
	<u>Consumables</u>				
	Solar salt (50 lb bag/ 7,000 gallons treated water)	124	\$5	\$643	\$5.17 if buying 850lbs plus from Culligan Water Supply
	Replacement Sybron SR-7 Resin	5	\$280	\$1,400	2.5 ft3/column, replace perchlorate resin every year, every two years for nitrate resin
	Electricity costs	3267	\$0.10/kwhr	\$327	Based on 2 hp pump, operating for 25% of the time
	Disposal of regeneration waste (cost per 55 gallon drum)	316	\$700	\$221,475	\$700/drum including administrative costs, Rob Tagesson 7/28/99
	Disposal of resin	1	\$700	\$700	
	<u>Facility Documentation and Data Collection</u>				
	E300:00 Nitrate samples	24	\$10	\$240	BC labs, \$10 for 20d TAT, say once month for influent and effluent
	Perchlorate Samples	24	\$110	\$2,640	Cal Test, \$110 per sample
	Data management time	48	\$37.50/analysis	\$1,800	
	Nitrate Test kit	1	\$1,200		Includes enough ampules for influent/effluent sample every working day, 1 yr
	Total Operations and Maintenance Costs (per year)			\$262,105	
	Gallons treated per year (3.5gpm)			1,839,600	
	Kg nitrate removed per year (3.5 gpm)			44	
	Cost per gallon (overall)			\$0.16	
	Cost per gallon (yearly O&M)			\$0.14	
	Cost per kg nitrate treated (overall)			\$6,622	
	Cost per kg nitrate treated (O&M)			\$5,992	

APPENDIX F

Sample Calculations

Anion Exchange Resin for Superior Nitrate Removal

IONAC SR-7 has three times the selectivity for nitrates of any commercially available anion exchange resin, which enables it to remove nitrates from sulfate-bearing waters without the danger of 'nitrate dumping.' Dumping occurs in other resins when the nitrate capacity is exhausted and sulfate ions push nitrate ions off the active sites. When this occurs, the effluent will contain more nitrate than the influent. At times, the finished water can exceed the U.S. Environmental Protection Agency's maximum contaminant level of 10 mg nitrate as N/l.

IONAC SR-7 is ideal for small municipal systems and residential point-of-entry and point-of-use cartridges, because these have a tendency to be overrun and cause nitrates to be dumped. IONAC SR-7 has been specially prepared to meet drinking water standards and has passed taste and odor tests.

Typical Characteristics

IONAC SR-7 uses a trialkyl quaternary amine exchange group on spherical beads of styrene-divinylbenzene copolymer.

It has the following typical characteristics:

Particle size distribution (U.S. Standard Wet)	-16/+50 Mesh
Effective Size	0.45 to 0.50 mm
Total Weight Capacity	2.2 meq/g
Total Volume Capacity	0.8 meq/ml
Water Retention	48 to 52%
Whole Bead Count	>95%
Average Hardness (Minimum)	500g/bead
US FDA Extractable Test (ppm) with Deionized Water, Ethyl Alcohol, Acetic Acid	All non-detectable

Operating Conditions

Maximum operating temperature	212° F (100° C)
Minimum bed depth	30 in (76 cm)
Free board (rising space)	100%
Service flow rate	2-5 gpm/ft ³ (16-40 l/hr/l)
Backwash expansion	50% (minimum)
Regenerant concentration	NaCl 5-12%
Regenerant flow rate	0.25-0.5 gpm/ft ³ (2-4 l/hr/l)
Regenerant injection time	30-60 minutes
Displacement rinse volume	1 bed volume (minimum)
Displacement rinse flow rate	0.25-0.5 gpm/ft ³ (2-4 l/hr/l)
Fast rinse volume	9 bed volumes (minimum)
Rinse flow rate	Service flow rate

SYBRON IONAC[®] SR-7

CHEMICALS INC.

Advanced Anion Exchange Resin

Sample Calculations

The following example illustrates the use of the curves on page 3 to calculate nitrate leakage, throughput capacity and actual run length in a conventional nitrate removal system.

	ppm	Conversion Factor	ppm, CaCO ₃
Bicarbonate, HCO ₃	72.2	0.82	59.2
Sulfate, SO ₄	115.1	1.04	119.7
Nitrate, as N*	14.4	3.57	51.4
Chloride, Cl	36.3	1.41	51.2

Step 1 — Percent nitrate

$$\text{Percent nitrate} = \frac{\text{NO}_3 \text{ ppm as CaCO}_3}{\text{NO}_3 \text{ ppm as CaCO}_3 + \text{SO}_4 \text{ ppm as CaCO}_3} \times 100 \quad \text{OR} \quad \frac{51.4}{51.4 + 119.7} \times 100 = 30\%$$

— Nitrate leakage

Determine nitrate leakage (Fig. 3) at 30% nitrate and a regeneration level of 10 lbs (100% NaCl) per cubic foot of SR-7. Leakage is 36% of the influent nitrate level, or 18.5 ppm (mg/l) nitrate at CaCO₃ (5.17 ppm nitrate as N).

— Base nitrate capacity

Determine base nitrate capacity (Fig.4) using the same parameters as in Step 2. Capacity is 4.2 Kgr (4,200 grains) per cubic foot of resin.

— Actual run length**

$$\text{Actual run length} = \frac{\text{Throughput}}{(100\% - \% \text{ leakage})/100}$$

Throughput is found by dividing base nitrate capacity (4,200 grains/ft³) by influent load (3.0 grains/gal.), or 1,400 gal/ft³. Using this value and leakage from Step 2, run length is 2,188 gal/ft³ resin.

* If nitrates are expressed as NO₃, the conversion factor is 0.81

** Calculation does not include an equipment factor.

SYBRON IONAC[®] SR-7

CHEMICALS INC.

Advanced Anion Exchange Resin

Fig 1 IONAC SR-7
Pressure Drop vs. Bed Depth

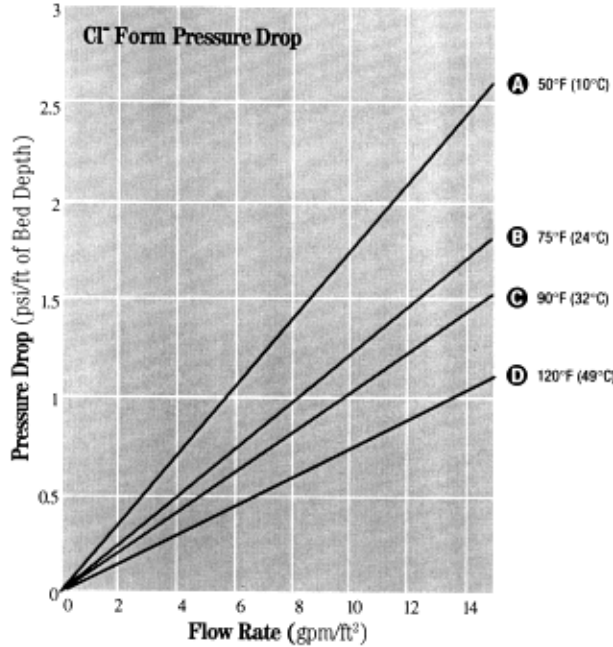

METRIC CONVERSION: m/hr = gpm/ft² x 2.54

Fig 2 IONAC SR-7
Backwash & Bed Expansion

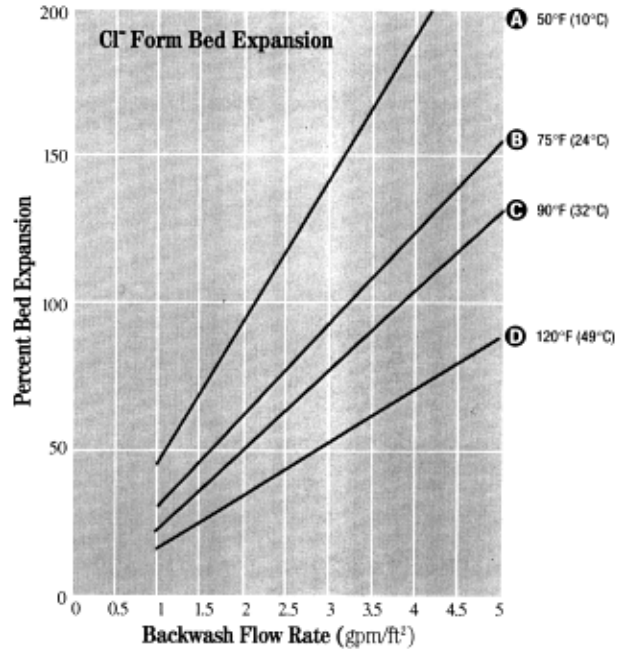

METRIC CONVERSION: m/hr = gpm/ft² x 2.54

Fig 3 IONAC SR-7
Nitrate Leakage vs. Regeneration Level

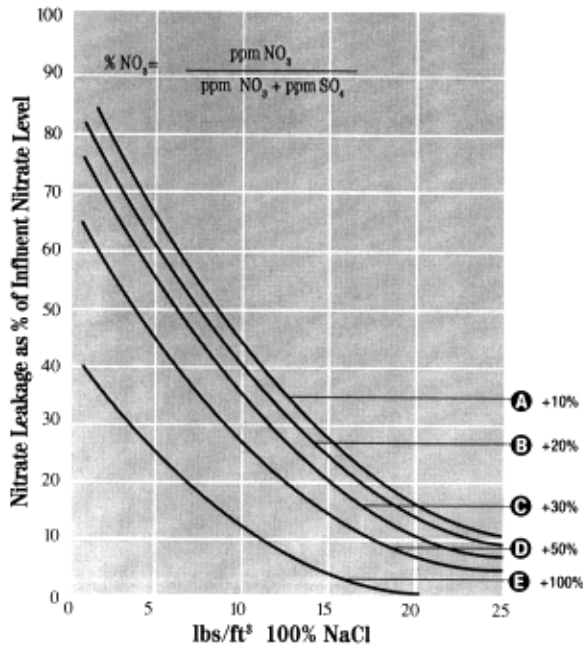

METRIC CONVERSION: g/l = lbs/ft³ x 16

Fig 4 IONAC SR-7
Nitrate Capacity vs. Regeneration Level

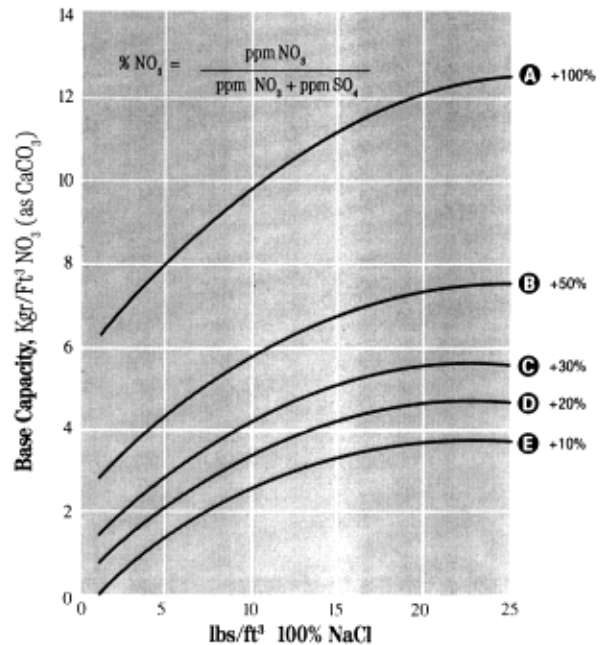

METRIC CONVERSION: g/l = lbs/ft³ x 16

APPENDIX G

Optimized Regeneration Cycle Times

Optimized Regeneration Times

Cycle	Krudico's Settings (min)	Optimized Time (min)
Backwash	10	10
Brine Draw/Slow Rinse	56	60
Rapid Rinse	6	6
Brine Tank Fill	36	15