

NAVAL AIR TRAINING COMMAND



NAS CORPUS CHRISTI, TEXAS

CNATRA P-764 (08-14) PAT

FLIGHT TRAINING INSTRUCTION



PRIMARY CONTACT T-6B

2014



DEPARTMENT OF THE NAVY
CHIEF OF NAVAL AIR TRAINING
250 LEXINGTON BLVD SUITE 102
CORPUS CHRISTI TX 78419-5041

CNATRA P-764
N716
8 Aug 14

CNATRA P-764 (08-14)

Subj: FLIGHT TRAINING INSTRUCTION, PRIMARY CONTACT, T-6B

1. CNATRA P-764 (08-14) PAT, "Flight Training Instruction, Primary Contact, T-6B" is issued for information, standardization of instruction and guidance to all flight instructors and student aviators within the Naval Air Training Command.

2. This publication shall be used as an explanatory aid to the T-6B Joint Primary Pilot Training curriculum. It will be the authority for the execution of all flight procedures and maneuvers herein contained.

3. Recommendations for changes shall be submitted via CNATRA TCR form 1550/19 in accordance with CNATRAINST 1550.6 series.

4. CNATRA P-764 (New 12-10) PAT is hereby cancelled and superseded.

A handwritten signature in cursive script, appearing to read "M. B. Tatsch", is positioned above the typed name.

M. B. TATSCH
By direction

Distribution:
CNATRA Website

FLIGHT TRAINING INSTRUCTION

FOR

PRIMARY CONTACT

T-6B

P-764



LIST OF EFFECTIVE PAGES

Dates of issue for original and changed pages are:

Original...0...17 Dec 09 (this will be the date issued)

Revision...1...12 Jan 11

Change Transmittal...1...26 Mar 12

Change Transmittal...2...18 Nov 13

Revision...2...08 Aug 14

Change Transmittal...1...23 Apr 15

Change Transmittal...2...10 Dec 15

Change Transmittal...3...21 Apr 16

TOTAL NUMBER OF PAGES IN THIS PUBLICATION IS 228 CONSISTING OF THE FOLLOWING:

Page No.	Change No.	Page No.	Change No.
COVER	0	6-34 (blank)	0
LETTER	0	7-1 – 7-8	0
iii - viii	0	7-9 – 7-19	3
ix	3	7-20 (blank)	0
x – xiv	0	8-1 – 8-4	0
1-1 – 1-11	0	9-1 – 9-6	0
1-12 (blank)	0	9-7 – 9-16	3
2-1 – 2-20	0	9-17 – 9-26	0
3-1 – 3-20	0	10-1 – 10-3	0
4-1 – 4-13	0	10-4 (blank)	0
4-14 (blank)	0	11-1 – 11-7	0
5-1 – 5-4	0	11-8 (blank)	0
5-5 – 5-6	2	A-1	0
5-7 – 5-25	0	A-2 (blank)	0
5-26 – 5-28	3	B-1 – B-14	0
5-29 – 5-34	0		
6-1 – 6-3	0		
6-4 – 6-7	1		
6-8 – 6-12	0		
6-13	1		
6-14 – 6-25	0		
6-26 – 6-27	3		
6-28 – 6-33	0		

INTERIM CHANGE SUMMARY

The following Changes have been previously incorporated in this manual:

CHANGE NUMBER	REMARKS/PURPOSE

The following interim Changes have been incorporated in this Change/Revision:

INTERIM CHANGE NUMBER	REMARKS/PURPOSE	ENTERED BY	DATE
1	Changes made per transmittal letter 23 Apr 15	CAS	
2	Changes made per transmittal letter 10 Dec 15	CAS	
3	Changes made per transmittal letter 21 Apr 16	CAS	

INTRODUCTION

COURSE OBJECTIVE:

Upon completion of this course, the Student Naval Aviator will be able to safely pilot a T-6B including takeoff, aerobatics, and landing phases.

STANDARDS:

Conditions and standards are defined in CNATRAININST 1542.166 series.

INSTRUCTIONAL PROCEDURES:

1. This is a flight training course and will be conducted in the aircraft and the UTD/OFT flight simulators.
2. The student will demonstrate a functional knowledge of the material presented through successful completion of the flight maneuvers.

INSTRUCTIONAL REFERENCES:

1. T-6B NATOPS Flight Manual.
2. Local Standard Operating Procedures Instruction.

TABLE OF CONTENTS

LIST OF EFFECTIVE PAGES.....	iv
INTERIM CHANGE SUMMARY.....	v
INTRODUCTION.....	vi
TABLE OF CONTENTS	vii
TABLE OF FIGURES.....	xii
CHAPTER ONE - INTRODUCTION TO T-6B CONTACT	1-1
100. INTRODUCTION	1-1
101. HISTORY OF CONTACT TRAINING	1-1
102. SCOPE OF INSTRUCTION	1-2
103. CURRICULUM RESOURCES.....	1-2
104. ACADEMIC/FLIGHT SUPPORT TRAINING	1-4
105. STANDARDS OF PERFORMANCE	1-4
106. THE FLIGHT INSTRUCTOR	1-5
107. THE STUDENT NAVAL AVIATOR.....	1-6
108. TRAINING TIME OUT	1-7
109. CREW RESOURCE MANAGEMENT	1-8
110. PHYSICAL/PSYCHOLOGICAL FACTORS.....	1-9
111. FLIGHT SIMULATORS.....	1-10
112. THE AIRCRAFT	1-11
CHAPTER TWO - T-6B AERODYNAMICS AND FLIGHT CONTROLS.....	2-1
200. INTRODUCTION	2-1
201. THEORIES OF FLIGHT	2-1
202. STABILITY AND CONTROL	2-7
203. STALLS.....	2-10
204. PRIMARY FLIGHT CONTROLS.....	2-12
205. SECONDARY FLIGHT CONTROLS - TRIM DEVICES	2-16
206. TRIM REQUIREMENTS - RUDDER/ELEVATOR.....	2-18
207. PERFORMANCE.....	2-19
208. POWER CONTROL LEVER.....	2-19
CHAPTER THREE - FUNDAMENTAL FLIGHT CONCEPTS.....	3-1
300. INTRODUCTION	3-1
301. FUNDAMENTAL FLIGHT MANEUVERS	3-1
302. INTEGRATED FLIGHT INSTRUCTION	3-1
303. ATTITUDE FLYING	3-2
304. "SEE AND AVOID" DOCTRINE	3-3
305. FLIGHT INSTRUMENTS	3-5
306. SCAN PATTERN.....	3-6
307. BALANCED FLIGHT.....	3-9
308. TURNS	3-10
309. THE ONE-THIRD RULE.....	3-13
310. SKID	3-13

311.	SLIP	3-14
312.	WIND EFFECTS AND CRAB CORRECTIONS.....	3-16
313.	CLIMBING FLIGHT.....	3-17
314.	CLIMBING TURNS.....	3-18
315.	DESCENDING FLIGHT.....	3-19
316.	THE P.A.T. PRINCIPLE	3-19
317.	ASSUMING CONTROL OF THE AIRCRAFT	3-20
CHAPTER FOUR - GROUND PROCEDURES.....		4-1
400.	INTRODUCTION	4-1
401.	NAVAL AVIATION LOGISTICS COMMAND MAINTENANCE INFORMATION SYSTEM.....	4-2
402.	CHECKLISTS	4-2
403.	BASIC 1001.....	4-3
404.	PREFLIGHT PLANNING/BRIEFING	4-3
405.	PREFLIGHT INSPECTION.....	4-5
406.	STRAPPING IN TO THE SEAT	4-6
407.	INTERIOR INSPECTION.....	4-8
408.	STARTING PROCEDURE	4-8
409.	TAXIING.....	4-9
410.	OVERSPEED GOVERNOR CHECKLIST	4-11
411.	BEFORE TAKEOFF CHECKLIST	4-11
412.	AFTER LANDING CHECKLIST.....	4-11
413.	ENGINE SHUTDOWN CHECKLIST.....	4-12
414.	POSTFLIGHT CHECKS.....	4-12
415.	ALDIS LAMP SIGNALS.....	4-13
CHAPTER FIVE - FLIGHT PROCEDURES.....		5-1
500.	INTRODUCTION	5-1
501.	CONTACT FLIGHT TERMINOLOGY	5-1
502.	OPERATIONS CHECKS.....	5-2
503.	ASSUMING CONTROL OF THE AIRCRAFT	5-2
504.	COMMUNICATIONS	5-3
505.	TAKEOFF.....	5-3
506.	CROSSWIND TAKEOFF	5-7
507.	DEPARTURE.....	5-8
508.	STRAIGHT AND LEVEL FLIGHT	5-8
509.	BASIC TRANSITIONS.....	5-12
510.	PROCEDURES.....	5-12
511.	CONSTANT ANGLE OF BANK TURNS	5-15
512.	TURN PATTERN.....	5-16
513.	LEVEL SPEED CHANGE.....	5-18
514.	STALLS.....	5-20
515.	ENERGY MANAGEMENT	5-21
516.	SLOW FLIGHT (SCATSAFE) MANEUVER.....	5-22
517.	POWER-ON-STALLS	5-24

518.	POWER-OFF STALL (ELP STALL).....	5-25
519.	LANDING PATTERN (APPROACH TURN) STALLS.....	5-27
520.	SLIP.....	5-28
521.	SPIN.....	5-30
CHAPTER SIX - LANDING PROCEDURES.....		6-1
600.	INTRODUCTION.....	6-1
601.	LANDING PATTERN.....	6-1
602.	LANDING PATTERN TERMINOLOGY.....	6-1
603.	OUTLYING FIELD ENTRY.....	6-3
604.	THE BREAK.....	6-4
605.	LANDING PATTERN.....	6-6
606.	APPROACH.....	6-6
607.	LANDINGS.....	6-15
608.	CROSSWIND APPROACH.....	6-20
609.	CROSSWIND LANDING.....	6-23
610.	WAVEOFF (GO-AROUND).....	6-26
611.	LANDING ERRORS.....	6-27
612.	OUTLYING FIELD DEPARTURE.....	6-31
613.	VFR STRAIGHT-IN APPROACH.....	6-32
CHAPTER SEVEN - EMERGENCY PROCEDURES.....		7-1
700.	INTRODUCTION.....	7-1
701.	ABORTED TAKEOFF DEMONSTRATION.....	7-3
702.	EMERGENCY LANDING PATTERN (ELP).....	7-3
703.	PRECAUTIONARY EMERGENCY LANDING (PEL).....	7-11
704.	PRECAUTIONARY EMERGENCY LANDING FROM THE PATTERN.....	7-14
705.	ENGINE FAILURE DURING FLIGHT (POWER LOSS).....	7-16
706.	EMERGENCY VOICE REPORTS.....	7-19
CHAPTER EIGHT - SOLO FLIGHT.....		8-1
800.	INTRODUCTION.....	8-1
801.	THE SOLO FLIGHT.....	8-1
CHAPTER NINE - AEROBATICS.....		9-1
900.	INTRODUCTION.....	9-1
901.	RULES AND PRECAUTIONS FOR AEROBATIC FLIGHT.....	9-1
902.	SECTION LINES AND GROUND REFERENCE POINTS.....	9-2
903.	CLEARING TURNS.....	9-2
904.	G-INDUCED LOSS OF CONSCIOUSNESS.....	9-3
905.	CONTACT UNUSUAL ATTITUDES.....	9-5
906.	LOOP.....	9-9
907.	WINGOVER.....	9-11
908.	BARREL ROLL.....	9-14
909.	AILERON ROLL.....	9-16
910.	SPLIT-S.....	9-17

911.	CUBAN EIGHT.....	9-19
912.	IMMELMANN.....	9-21
913.	CLOVERLEAF.....	9-23
914.	COMBINATION MANEUVER.....	9-25
915.	INVERTED FLIGHT.....	9-25
CHAPTER TEN - ANGLE OF ATTACK APPROACHES.....		10-1
1000.	INTRODUCTION.....	10-1
1001.	ANGLE OF ATTACK APPROACHES.....	10-1
CHAPTER ELEVEN - NIGHT CONTACT.....		11-1
1100.	INTRODUCTION.....	11-1
1101.	NIGHT FLYING PHYSIOLOGY.....	11-1
1102.	PERSONAL PREPARATION.....	11-2
1103.	NIGHT GROUND PROCEDURES.....	11-2
1104.	PREFLIGHT PROCEDURES.....	11-2
1105.	LIGHT SIGNALS.....	11-2
1106.	START.....	11-3
1107.	TAXI.....	11-3
1108.	NIGHT FIELD LIGHTING.....	11-3
1109.	OVERSPEED GOVERNOR CHECKLIST.....	11-4
1110.	INBOUND TAXI PROCEDURES.....	11-4
1111.	ENGINE SHUTDOWN.....	11-4
1112.	POSTFLIGHT INSPECTION.....	11-4
1113.	NIGHT CONTACT FLIGHT PROCEDURES.....	11-4
1114.	TAKEOFF PROCEDURES.....	11-5
1115.	HOMEFIELD DEPARTURE.....	11-5
1116.	LANDING PATTERN.....	11-5
1117.	WAVEOFF.....	11-6
1118.	HOMEFIELD ARRIVALS.....	11-6
1119.	HOMEFIELD BREAK.....	11-6
1120.	LANDING.....	11-6
1121.	NIGHT EMERGENCY PROCEDURES.....	11-7
1122.	VISUAL AIRCRAFT-TO-AIRCRAFT SIGNALS.....	11-7
APPENDIX A - GLOSSARY OF TERMS.....		A-1
A100.	GLOSSARY - N/A.....	A-1
APPENDIX B - COMMUNICATIONS.....		B-1
B100.	INTRODUCTION.....	B-1
B101.	COMMUNICATION.....	B-1
B102.	CALL SIGNS.....	B-2
B103.	VERBALIZATION.....	B-3

APPENDIX C - THE PRE-FLIGHT BRIEF	C-1
C100. AN OVERVIEW	C-1
C101. THE BRIEFING	C-2

TABLE OF FIGURES

Figure 2-1	Angle of Attack	2-2
Figure 2-2	Torque Effect	2-4
Figure 2-3	Gyroscopic Effects	2-5
Figure 2-4	Slipstream Effect	2-6
Figure 2-5	P-Factor	2-7
Figure 2-6	Aircraft Axes	2-8
Figure 2-7	Static Stability	2-9
Figure 2-8	Cases of Stability	2-9
Figure 2-9	Aircraft Axes	2-13
Figure 2-10	Aileron Control	2-14
Figure 2-11	Adverse Yaw	2-14
Figure 2-12	Control Stick	2-17
Figure 2-13	PCL	2-20
Figure 3-1	Outside Scan	3-5
Figure 3-2	Side-to-Side Scanning Method	3-8
Figure 3-3	Front-to-Side Scanning Method	3-9
Figure 3-4	Coordinated vs. Uncoordinated Turns	3-11
Figure 3-5	Skidded vs. Coordinated Turn	3-14
Figure 3-6	Coordinated vs. Slip Turn	3-15
Figure 3-7	"Crabbing" Flight Path	3-17
Figure 4-1	T-6B Taxiing	4-1
Figure 4-2	Strapping into the Seat	4-7
Figure 4-3	Canopy Lock Indicator	4-8
Figure 4-4	Nose Wheel Steering Button	4-10
Figure 4-5	Aldis Lamp Signals	4-13
Figure 5-1	Contact Flight Terminology	5-1
Figure 5-2	The Takeoff Roll, Rotation, and Initial Climb	5-3
Figure 5-3	Climb Rate	5-4
Figure 5-4	Skipping on Takeoff	5-8
Figure 5-5	Straight and Level Flight	5-9
Figure 5-6	Climb Attitude ~8° Nose High	5-13
Figure 5-7	Turn Pattern	5-17
Figure 6-1	Landing Pattern	6-5
Figure 6-2	90° Position	6-9
Figure 6-3	The "Groove"	6-10
Figure 6-4	Aimpoint	6-11
Figure 6-5	Glideslope Corrections	6-13
Figure 6-6	Landing Pattern From Downwind Leg to Landing	6-15
Figure 6-7	Overshooting Crosswind	6-20
Figure 6-8	Undershooting Crosswind	6-21

Figure 6-9	Crabbing	6-21
Figure 6-10	Desired Path	6-22
Figure 6-11	The "Box Pattern"	6-33
Figure 7-1	Emergency Landing Pattern (ELP) Checkpoints	7-8
Figure 7-2	Emergency Landing Pattern	7-8
Figure 9-1	Aerobatic Maneuver Parameters	9-1
Figure 9-2	Nose-High Recovery	9-6
Figure 9-3	Nose-Low Recovery	9-8
Figure 9-4	Loop	9-9
Figure 9-5	Wingover	9-11
Figure 9-6	Barrel Roll	9-14
Figure 9-7	Aileron Roll	9-16
Figure 9-8	Split-S	9-18
Figure 9-9	Cuban Eight	9-20
Figure 9-10	Immelmann	9-22
Figure 9-11	Cloverleaf	9-23
Figure B-1	Range Reception Chart	B-2
Figure B-2	Phonetic Alphabet	B-6

THIS PAGE INTENTIONALLY LEFT BLANK

CHAPTER ONE INTRODUCTION TO T-6B CONTACT

100. INTRODUCTION

This Flight Training Instruction (FTI) is a Naval Air Training Command directive published by Chief of Naval Air Training (CNATRA). The information and instructions are relative to all instructors and Student Naval Aviators (SNA) operating T-6B aircraft in the Primary Phase of training in the Naval Air Training Command. It is very important that the factual material contained herein be thoroughly studied and retained.

The process by which a student is transformed into a skilled naval aviator is both complex and demanding. It can be accomplished only by intensive instruction in the air as well as in the classroom. Success, for the most part, depends upon the student's attitude, cooperation, and attention to detail. The degree of skill attained by students depends largely upon their ability to understand new material and to work hard. Those students who cannot measure up to the high standards required throughout the various phases of training, because of either their lack of motivation or ability, must and will be attrited.

This FTI does not contain all the information necessary for a student pilot to become a professional aviator. Rather, this instruction provides a focal point and reference manual for all other sources of technical information, outlining and amplifying the flight procedures where necessary. This manual is designed as a training tool and is not meant to establish policy concerning fleet operations. Every effort has been made to remain in accordance with current fleet procedures. It is important to note that the emergency procedures shown are to aid in the topic discussion. For all emergencies, the T-6B NATOPS Flight Manual is the final authority. Through this cross-referencing and organization of information, the student pilot should be able to develop a thorough understanding of the manual and flight procedures that form the backbone of an aviation career.

Congratulations on your commencement of primary flight training. Your hard work and determination has earned you the unique opportunity to become part of the most elite team of aviation warriors in the world today. The United States Naval Aviator is a highly trained professional. The tremendous level of skill demanded by the naval air community can only be obtained through total dedication and sustained maximum effort. It is imperative that every Student Naval Aviator apply himself or herself completely. Anything less than your best effort is unacceptable. Best of luck in your endeavor to earn your "Wings of Gold."

101. HISTORY OF CONTACT TRAINING

Naval aviation training has come a long way since 1910 when Lieutenant T. G. Ellyson was ordered to flight instruction to become the first Naval Aviator. Soon thereafter, the U.S. Navy purchased its first airplane, the Curtis Triad, at a cost of \$5,500. Since that time, naval aviation technology has progressed at a rapid rate. The fleet aircraft of today's Navy are tremendously complex and demanding machines, capable of astonishing performance. Advancements in aviation technology are only part of a much bigger picture. Even the most modern aircraft will

fail to accomplish its mission if piloted by a poorly trained or incompetent aviator. Therefore, a thorough and comprehensive training program is essential for mission accomplishment.

Early aviation pioneers suffered through many "accidents," which became unwanted yet commonplace occurrences. A "good" landing was any one that you could walk away from! Today, the safety record of naval aviation is the best it has ever been. Accidents or "mishaps" are rare, yet do occur. Anything greater than a zero mishap rate is undesirable. Mishap-free operation is the ultimate goal, and SAFETY is a primary concern during all aspects of training. There is NO acceptable loss and NO toleration for anything less than total professionalism. This is a goal we can achieve. Your instructors will set an example that you should strive to mirror.

102. SCOPE OF INSTRUCTION

So far as is practical, all information and instructions governing T-6B aircraft procedures and the execution of curriculum maneuvers will be published for inclusion in this manual. Procedures peculiar to Whiting Field (TW-5) and Corpus Christi (TW-4) may be found in the TW-5 Fixed Wing Operating Procedures (FWOP) Manual or TW-4 Standardization Notes/NAS Corpus Christi Course Rules.

Terms that would be included ordinarily in a glossary for T-6B Contact training are defined as they are used throughout the text.

1. **Learning Objectives.** The course objective is broken down into Stage (Terminal) Learning Objectives. Terminals are further broken down into Enabling Learning Objectives. These are designed to be smaller, bite-size chunks of the overall objective. The Terminal Objectives are listed in the CNATRA governing instruction.
2. **Enabling Objectives, Maneuvers and Exercises.** Each event in this stage is comprised of various tasks the student will have to perform. This could be performing a spin on a contact flight, or reciting an emergency procedure during a lecture, or answering a test question correctly in an end-of-course exam. The Joint Primary Pilot Training (JPPT) Curriculum, Flight Training Instruction, and Academic Training Instruction break down each of these tasks in detail.

The maneuvers or other items that you will perform on the events may be graded or nongraded. This means that this particular item may or may not be used to compare you to course training standards. This does not mean that the instructor may not evaluate a nongraded item. The student is just as responsible, for example, for a demo (nongraded) item as for a graded item. If the instructor determines a blatant lack of preparation for either, an unsatisfactory grade is warranted.

103. CURRICULUM RESOURCES

1. **T-6B Joint Primary Pilot Training (JPPT) Master Curriculum Guide (MCG)**

CNATRAINST 1542.166. This pocket guide is the curriculum outline. It describes what each Student Naval Aviator (SNA) will do in the Primary phase of training. The maneuvers and exercises in the syllabus are described, as well as the standards of performance to be achieved. Each event lists all of the maneuvers to be performed. When there is no task listing in the description of an event, then another publication describes the conduct of that event. For example, although the Joint Primary Pilot Training System (JPPT) Curriculum simply lists Aerodynamics as the event, the Aerodynamics Academic Training Instruction (ATI) lists the material to be covered.

2. **Flight and Academic Training Instructions.** These are called "peculiar to aviation training" (PAT) pubs and are produced by CNATRA specifically for each of its curricula. These PAT pubs describe the various maneuvers and exercises the SNA will be required to perform, and list any additional pubs or study material that the student may need to reference for an event. The SNA is responsible for all material listed in these training instructions. Each stage of training has an associated FTI containing the information necessary for a student to complete the curriculum satisfactorily. It is every pilot's responsibility to be thoroughly familiar with the contents of this manual. Strict adherence to the manner of execution of maneuvers, patterns, procedures and instructions herein promulgated is mandatory for all instructors and Student Naval Aviators operating the T-6B aircraft.

3. **1500.4 (TA Manual) and the Aviation Training Jacket.** CNATRAINST 1500.4 is commonly referred to as the Training Administration (TA) manual. The TA manual is Student Control's guide to handling its students. Normally, those areas of the TA manual for which the SNA is responsible will be outlined to the student upon check in. Such student responsibilities always include obtaining jacket reviews, ensuring Aviation Training Forms (ATF) make their way to the Aviation Training Jacket (ATJ), and updating the calendar card. These responsibilities should not be taken lightly. The responsibility (or lack thereof) that a student displays with these administrative details can be a direct indication of how seriously a student is applying himself/herself to an aviation training program.

4. **Aviation Training Forms.** These are records of the training events that take place for a student. They also record the instructor's evaluation of student performance. These are permanent, official documents that remain in the SNA's jacket forever. They are never removed or altered by anyone except under very special circumstances listed in the TA manual. Any student who alters or removes an ATF from his or her jacket will be subject to attrition under the provisions of the TA manual.

5. **NATOPS Program.** Every Student Naval Aviator becomes familiar with Naval Air Training and Operating Procedures Standardization (NATOPS) early in his or her career. You will be issued a T-6B NATOPS Flight Manual before you start ground school, and a General NATOPS (OPNAVINST 3710.7) should be available to you. The NATOPS program is the responsibility of all who use it. NATOPS only works if everyone is involved. Even as a Student Naval Aviator, it is your responsibility to originate changes if you find errors or ambiguities in the T-6B NATOPS Flight Manual. See the squadron NATOPS officer regarding the correct procedure to submit a change recommendation to the NATOPS Flight Manual.

6. **T-6B NATOPS Flight Manual and Pocket Checklist.** The T-6B NATOPS Flight Manual is the definitive instruction on the operation of the aircraft. The Pocket Checklist (PCL) is a convenient pocket sized listing of those items in the T-6B NATOPS Flight Manual that would be of particular concern while airborne or at a remote location. No student or flight instructor has the authority to deviate from the Flight Manual without specific written authority except in specific situations. The T-6B NATOPS Flight Manual also lists the crew requirements for flying the aircraft. There is a bank of questions in the back of the T-6B NATOPS Flight Manual that every aviator should be familiar with. Both the T-6B NATOPS Flight Manual and the PCL list emergency procedures. Some of these procedures are listed in **Boldface** or with asterisks next to them. These items are memory items, and the SNA shall be able to recall and apply any of these procedures correctly to the appropriate aircraft malfunction. In addition to the emergency procedures, a pilot should be able to recall the Landing Checklist from memory. Other than these, every checklist should be performed with the aid of the PCL or appropriate guide. Familiarity with the PCL should be acquired in an attempt to ensure efficient use under potentially arduous situations while airborne.

In Primary Training, there is no room for libraries of publications. T-6B aircrews must be thoroughly familiar with their aircraft. They must study the NATOPS Flight Manual in-depth and have a thorough knowledge of it because no opportunity exists to do so while airborne. The T-6B NATOPS Flight Manual requires the use of checklists. Although a student may become familiar with a checklist, pocket checklists are to be used to ensure no items are missed.

104. ACADEMIC/FLIGHT SUPPORT TRAINING

The terminal objective of flight support training and academics is to provide the SNA with the basic knowledge and skills directly applicable to satisfactory progression in the T-6B aircraft flight training. Upon completion of the academic and flight support activities, the student will be capable of relating these acquired cognitive skills and applying them through simulation and actual flights, thus developing the motor skills and headwork necessary to meet CNATRA standards to complete primary flight training.

105. STANDARDS OF PERFORMANCE

1. **Standardization.** Flight instruction must be highly standardized. The syllabi that are currently being used are the result of constant evolution, and the procedures taught are lessons learned over the course of many years. The FTI and T-6B NATOPS Flight Manual set forth the one standardized way of doing any specific maneuver. Adherence to these standards will be a part of any instructor's evaluation of a student's performance during an event. Occasionally, a student may question a particular instructor's technique, or he may think that an instructor is incorrect. There is no time for protracted discussion or debate in the air. If an instructor's request is unclear to the student, the student must request clarification. If, however, the student feels that the instructor's methods contradict the T-6B NATOPS Flight Manual or the FTI, he should consult his class advisor on the appropriate way to address the issue. In any event, when the student feels that flight safety is in jeopardy, he is bound to request a Training Time Out to obtain clarification. Training Time Out is defined in section 108 of this publication.

The standard flight procedures employed in the training syllabus are universal to all Navy aircraft, except when slight deviations have been adapted in the interest of flight safety.

Maximum utilization of instructor/aircraft time demands a thorough knowledge of the flight training instructions and referenced publications by both the flight student and instructor. The time designated for the pre-flight briefing is equally limited and demands that both student and instructor have a complete knowledge of the material to be covered in preparation for the flight. Briefing time should be applied to review of previous difficulties, clarification of misunderstandings, and immediate flight planning. It is essential that the instructor and the student have a common understanding of the maneuvers to be flown and employ the same nomenclature in order to take full advantage of the time afforded.

2. **Grades.** The adage is that if you worry about learning, the grades take care of themselves. The truth is that one should be trying to perform to the best of his or her ability at all times. Grades are designed to do two things: compare performance to a set standard or criterion; and contrast performance of individuals within the same curriculum.

There is little to be gained by sweating over grades. The nature of flight training is such that if one misses a step, it is very difficult to catch up. The syllabus is designed to give the average student sufficient time and opportunity to complete the objectives. When it becomes apparent to an instructor that objectives are not being met, or the student is having difficulty, the student's grades will reflect this. The student should not take grades as a personal affront. The instructor should make every effort not only to critique the student, but also to give the student the information required to perform the exercise or maneuver in an acceptable manner. The best instructors are not those who give the best grades, but those who best prepare the students for their next flight. Students should concentrate on correctly performing the maneuvers of the next hop, and meeting the stage and phase objectives. Students who are able to do this are successful in the Naval Air Training Command.

3. **Check Flights.** The student should place no special significance on designated check flights and should not anticipate failure if a superlative performance is not demonstrated. The designated check flight is merely a validation by another instructor of the evaluations previous instructors have given to the student. If a student fails to meet the accepted standards of progress, the instructor will grade the student's performance unsatisfactory rather than allow him/her to continue in the syllabus. The check pilot is obligated to judge the student fairly in comparison with accepted standards.

106. THE FLIGHT INSTRUCTOR

The flight instructor is an experienced aviator, trained to provide the student with a sound foundation in the operation of the aircraft. He/She has undergone a training course similar to the student's syllabus, which familiarizes him/her with the curriculum maneuvers and teaches an effective means of presenting them. This training comes under the heading of standardization. The intent of standardization is to provide the instructor with a logical, effective, and consistent foundation upon which to present any maneuver. This in turn ensures that all students can be judged on the same basis, each having been exposed to the same material and afforded an equal

opportunity to demonstrate his/her abilities. No two instructors will be identical in their techniques and each may vary his/her presentation to fit the needs of the individual student.

In order to teach you to fly the T-6B properly, the instructor must criticize! His/her comments on your performance of the various maneuvers are intended to improve your understanding. All criticism by the instructor is meant to be constructive in character. The instructor's sole intent is to instill confidence and develop you into a qualified Naval Aviator.

Your flight instructor is a vital part of your training. Nonetheless, you must do your part as well. The one word that you will hear most from your instructor is "**PROCEDURES!**" In order that your time in the aircraft can be devoted to the improvement of maneuver performance, it is imperative that you learn, memorize, and understand the procedural steps required in performing each of the various maneuvers. Then and only then can your instructor's time with you be profitably utilized. The instructor is well trained and qualified to teach his/her student, but his/her success requires the fullest cooperation of the student himself/herself. If you have questions about procedures or concepts, ask them. Knowing procedures, both for normal and emergency operations, cannot be overemphasized! They must be over-learned so that they can be recalled in flight, especially during periods of high cockpit workload and stressful situations.

Contract Instructors. Simulator instructors are generally civilians, contracted to the Navy to provide simulator flight instruction and teach academics. These instructors are all experienced military aviators. They are bound by the same instruction as their military counterparts. The simulator event should be treated just as a flight event. Both events require the same dedicated preparation and forethought. The contract instructor (CI) is also responsible for standardization. If you notice a nonstandard maneuver or technique, bring it to the attention of the standardization officer at the squadron.

107. THE STUDENT NAVAL AVIATOR

The qualifications to become a SNA are high. The SNA has been selected for flight training by a screening process that determines his/her superiority over the average American youth with respect to physical condition, intelligence, ability to grasp and retain new ideas, and apparent emotional stability. Superior reasoning ability will enable him/her to combine these talents into experience that will produce a qualified naval aviator. One critical factor of success, which cannot be accurately evaluated by the normal selection process, is mental attitude. Mental attitude, as much as any other factor, determines the ease or difficulty with which the student progresses through the training syllabus. Under the heading of positive mental attitude come such elements as willingness to conform to military discipline, acceptance of curtailed personal freedom and leisure, and the ability to encounter occasional reverses and still maintain enthusiasm and self-confidence.

Motivation and mental attitude are closely related. The student's motivation greatly affects his or her mental attitude and consequently his or her progress throughout training. The majority of students have had little or no previous aviation experience. Flight training is arduous and places great demands on the student's time and energy. Therefore, motivation plays an important part in difficult periods. The student who discovers that he or she does not enjoy flying but remains

because of prestige or monetary compensation will find that his or her chances of successfully completing the program are poor. The desire to earn those coveted wings of gold and the love of flying provide the highest motivation and the greatest likelihood of success.

With these basic qualities as a foundation, the experience you gain as you progress through each stage of your training will develop the many facets of your skill and judgment. This will allow you to cope with the many and varied problems that may confront you in the handling of your aircraft under all conditions. Although your instructor and other personnel are at your disposal to help solve various problems, your own intelligent analysis, based on acquired knowledge, will generally permit you to arrive at correct and logical conclusions.

Flying is a highly physical attribute and, like many other acts of a physical nature, is mostly a matter of coordination of hands, feet and eyes. As far as controlling the attitude and performance of the aircraft is concerned, the elementary methods of flying are not at all difficult to master. But, because it is performed in an environment to which you will not be accustomed, you may experience some difficulty adapting to the airborne classroom. With your instructor's patience and your own hard work and alertness, the readjustment required will occur naturally and you will find that the T-6B is one of the most enjoyable classrooms in the world. Every student should remember these guidelines when managing his/her training program.

- Your flight instructor wants you to learn to be a professional aviator. If in doubt, ask questions and use your flight instructor to help you through problem areas.
- Preparation is the key to professionalism. Do not be satisfied with only knowing enough to complete the hop. What is being taught in the primary phase has a direct transference to all future training.

Remember one important thing for as long as you fly an aircraft: You must be your own most aggressive critic. This does not mean that you become a mental case in the cockpit, but it does mean that as an aviator beginning the flight training syllabus, you must demonstrate one of the most critical qualities of a professional aviator: self-discipline. This means that you prepare for every hop as if your professional reputation is at stake. Your flights are not contests where someone is keeping score and counting your mistakes. Your flight grades should not be as important as your own honest assessment of your flight performance. You are expected to come well prepared, but you must expect to make mistakes. Most of these mistakes are forgiven as long as you deal with them professionally, on the spot and learn from them. That is why they call this flight training.

108. TRAINING TIME OUT

CNATRAINST 1500.4 (series) defines the conditions under which a Training Time Out (TTO) may be requested. A TTO may be called in any training situation whenever a student or instructor expresses concern for personal safety or a need for clarification of procedures or requirements exists.

The intent of TTO is to give students and instructors the means to stop a flight if they are not "communicating" or if either party feels they are in an unsafe position. It will not be used to terminate a flight just because you are having a bad day or do not know your procedures. Nevertheless, do not be hesitant to use TTO if you feel the flight conditions warrant it.

109. CREW RESOURCE MANAGEMENT

The "Human Error" factor or inadequate Crew Resource Management (CRM) is the single leading causal factor for Class A mishaps in modern naval aviation. As defined in OPNAVINST 3710.7, CRM describes the use of "specifically defined behavioral skills as an integral part of every flight to improve mission effectiveness by minimizing crew preventable errors, maximizing crew coordination, and optimizing risk management." It includes all crew members, equipment, and external factors involving the flight from before the flight brief to after the flight debrief. See T-6B Flight Manual Section 8 Ch. 2.

During primary, you will be provided with both ground and flight CRM training. Since research and development began in 1991, the CRM program and its seven skills have become fully integrated into all aspects of naval aviation and are governed by CNAFINST 1542.7 (series). With the instructor/student relationship required by the nature of primary flight training, it is imperative that both instructors and students actively practice good CRM to ensure that safety is maintained at all times. This should not preclude the instructors from ensuring students are able to perform as single-pilots, but should provide guidance to maintain safety in the cockpit.

1. **Sandbag Syndrome.** The sandbag syndrome is based on a comforting premise that one or more other crew members have the situation under control and are looking out for your best interest. It is a direct breakdown of CRM skills such as: leadership, assertiveness, and situational awareness. The sandbag syndrome is mainly experienced at certain times when the instructor pilot has assumed flying duties, such as breaks in training, approaches, enroute transits, etc. This effectively results in the SNA being "along for the ride." It is important to remember that no pilot is above the momentary lapse of judgment or situational awareness that could result in a flight violation or mishap. Do not let this happen to you! As a copilot, your primary responsibility is to support and back up the pilot at the controls.

Stay alert and be assertive when necessary. The instructor/student relationship often fosters reluctance on the part of the SNA to confront the Instructor Pilot (IP). But remember; do not let misplaced professional courtesies stand in the way of maintaining safe and efficient flying practices.

2. **"I'm Safe" Checklist.** As a rule, good aircrew coordination begins with the individual crew member. Our situational awareness resources might be lacking before we even set foot in the cockpit. Unfortunately, we do not have external readouts telling ourselves when they are diminished; therefore, it is important that every pilot conduct a daily personal preflight prior to each flight. "I'M SAFE" is a simple checklist to determine if we are ready and fit to fly. Do not show up for a brief without first conducting a personal preflight.

- I – Illness (Do you feel well?)
- M – Medication (Are you feeling any effects of medications taken?)
- S – Stress (Are there any adverse stresses in your life to distract you?)
- A – Alcohol (Are you free of all effects of alcohol consumed?)
- F – Fatigue (Are you well rested?)
- E – Eating (Did you eat properly before flying?)

110. PHYSICAL/PSYCHOLOGICAL FACTORS

To help you understand something of the physical and psychological factors affecting your training, the remainder of this chapter will be devoted to paraphrasing our flight surgeon's thoughts on the matter.

Physical ease and relaxation while flying makes the difference between the pilot flying the plane and the plane flying the pilot. A proper sense of "feel" of the aircraft is essential. Just as a good horseman must be sensitive to the movements of his mount, so must the aviator be sensitive to the movements of the airplane. This innate sense cannot be achieved in any other way than by the proper relaxation of all the body muscles and light touch on the aircraft's controls. The art of being relaxed in an airplane involves an awareness of what your body and mind are doing. A natural reaction to the strange environment or unusual situation is the age-old aviator tendency to "pucker" in a tight situation. Be alert for involuntary tensing of the muscles and you will find you quickly develop that sought-after "feel" and avoid the hard-to-break habit of mechanical flying. An important aspect of developing this sense of "feel" is knowing what you are going to do at all times and be prepared for the next evolution in your flight training. This is nothing more than knowing your PROCEDURES. Remember the panic in your school days when you were handed a test and it suddenly dawned on you that you had not studied, or what you had studied was not on the test?

Mental attitude is a very essential element to your relaxation in an aircraft. It affects your nervous system and, if allowed to continue in an unhealthy trend, can result in actual physical incapacitation. Therefore, its significance should be fully appreciated. As with physical handicaps, any mental distraction will also detract from the full use of your required senses. A poor mental attitude will interfere with your ability to concentrate, learn, and apply your knowledge. In turn, a good or positive mental attitude will increase your learning capacity and will make your flight training a pleasure rather than an unpleasant job.

If for any reason you find yourself "flying more, and enjoying it less," whether from some known cause or not, discuss it with your flight instructor or unit leader. Another aid to acquiring a positive mental attitude, after you have satisfied yourself that it is not an outside problem affecting you mentally, is to find some healthy diversion that will get your mind away from the subject of flying for a time. The base as well as the local area offers much in the way of recreational opportunities and diversions.

Mental alertness on the pilot's part has a direct bearing upon safety of flight as well as contributing significantly to the learning process. Remember that the training areas utilized are not very large and are used by many aircraft. Being constantly on the alert while flying may save your life and that of one of your squadron mates. Mental laziness is the constant enemy of every aviator. So, as you progress through flight training, plan ahead and try to anticipate all possible contingencies that could affect the operation of your aircraft. Proper planning not only refers to the environment around you but also the aircraft in which you are sitting. Check your engine instruments from time to time to ensure that all is well up front. In other words, train yourself to be alert to all facets of your flight rather than concentrating on the problem of the moment. You will find yourself surprised at the amount of information your eyes will transmit to your brain during a quick SCAN of your surroundings. Planning ahead will also equip you to take immediate and appropriate action should an emergency occur.

Confidence in your aircraft, your instructor, and most importantly yourself, is another essential element of flying. The basic ingredient to acquiring the confidence necessary to professionally pilot an aircraft is knowledge and efficient analytical application of that knowledge. The aircraft you are flying has been engineered to provide you with every safety feature known to the industry. The risks beyond the control of the pilot are minimal. Fire is an extremely rare occurrence. Engines are inherently reliable. In-flight collisions are rarities that are completely avoidable if you stay alert. With the above points in mind, it is readily apparent that the chance of an aviation accident caused by anything other than incompetence, disobedience or poor judgment is remote. Remember that 70% of all fatal accidents are due to 100% pilot error. With all this going for you, do not let human frailty or overconfidence develop, particularly while your experience is limited. The instant that a pilot begins to lose that feeling of respect due an aircraft, he has reached a stage when anything can happen and usually does. Good pilots are never caught unprepared in an emergency situation. They know and understand emergency procedures **COLD!** Humble confidence and perseverance will go a long way in striving for those Wings of Gold.

Occasionally, physiological problems arise during the course of a flight. airsickness, fatigue, hypoxia, food poisoning and dehydration can overcome a pilot and result in reduced situational awareness and even complete incapacitation. Pilots must not only recognize these symptoms in themselves but also in other crew members. At any time, the non-affected crew member should be ready to take the controls, and if necessary, fly to a safer environment (i.e., higher altitude, away from other aircraft and clouds) to include termination of the flight. airsickness is common during early Contact flights and, even though it is not usually incapacitating, it affects judgment and reduces situational awareness. If this occurs, inform your instructor.

111. FLIGHT SIMULATORS

You won't always have a formal training device at your disposal to prepare for your simulators and flights. "Chair flying" or "hangar flying" is an excellent way to prepare at home, preferably with a classmate. Strap your checklist on your knee, put on your gloves, grab a simulated control stick and mentally accomplish each segment of your imaginary flight. Visualize each procedural step of your planned maneuvers and verbalize your radio calls. "Chair flying" is a skill in itself and can reap major rewards in all phases of your training and throughout your career.

Simulators have proven to be valuable assets in helping students learn the physical attributes necessary to become a good pilot. Before you climb into the T-6B aircraft for the first time, you will have practiced the use of checklists, basic flight, and emergency procedures several times. There are 3 types of simulators available for your use: A static trainer, a Unit Training Device (UTD), and an Operational Flight Trainer (OFT). In addition to the syllabus training that you receive in the UTD or OFT, you should utilize the static trainers at every opportunity. Practice will pay off with better grades, increased self-confidence, and more professional performance.

UTD/OFT Flight Simulator. The UTD is a training device with no visual system designed to support procedural and instrument flight requiring no outside visual references. The OFT is a training device with a wide field of view visual system to support instrument and visual flight training. These simulators do not have full motion. The instruments and flight controls behave exactly as those in the aircraft. If there is a discrepancy in the device, it is the responsibility of the aircrew (you) to provide maintenance data. Normally, this consists of telling the simulator instructor about the problem. Do not be complacent about discrepancies on a flight simulator.

112. THE AIRCRAFT

The first aircraft you will fly in this program is the Hawker-Beechcraft T-6B “Texan II.” It is a pressurized two-place, tandem cockpit, low wing, high-performance, single engine monoplane equipped with dual controls. Power is provided by a turbo-prop engine manufactured by Pratt & Whitney Aircraft of Canada, Model PT6A-68, with inverted flight capabilities, providing a flight envelope with altitudes to 31,000 feet. Reference your T-6B NATOPS Flight Manual for detailed aircraft information and operating procedures.

THIS PAGE INTENTIONALLY LEFT BLANK

CHAPTER TWO T-6B AERODYNAMICS AND FLIGHT CONTROLS

200. INTRODUCTION

Prior to your first flight in the T-6B, there are several fundamental topics that you should review and understand if you are to obtain maximum benefit from your primary training. These topics include not only basic aerodynamics, but also certain principles pertaining to safety of flight. While more complex theories were covered in the classroom during Aviation Indoctrination, the basics are considered to be of sufficient importance to repeat in broad terms at this time. The discussions in this chapter provide Student Naval Aviators with the basic factors of flight before actually beginning to fly.

In addition, this chapter discusses the controls with which you will operate the aircraft about the three axes of motion, and how to use them effectively.

201. THEORIES OF FLIGHT

1. **Lift and Thrust.** Our discussion will include several basic laws of physics that help to explain how an airplane flies. Sir Isaac Newton is credited with having observed in 1687, ". . . for every action, there is an equal and opposite reaction . . ." This principle applies whenever two objects act upon each other, such as the air and the propeller, or the air and the wing of the airplane. In short, the statement about "action and reaction" tells us how lift and propulsion of airplanes are produced.

The predominant method by which air exerts force on a solid body, such as an airplane's wing, is through pressure. For our purposes, friction can be ignored. In the 1700's, Daniel Bernoulli (a Swiss mathematician) discovered the Venturi Principle. He found that if the velocity of a fluid (air) is increased at a particular point, the static pressure of the fluid (air) at that point is decreased. The airplane's wing is designed to increase the velocity of the air flowing over the top of the wing as it moves through the air. To do this, the top of the wing is curved, while the bottom is relatively flat. The air flowing over the top travels a little farther (since it is curving) than the air flowing along the flat bottom. This means the air on top must go faster. Hence, the static pressure decreases, resulting in a lower static pressure (as Bernoulli stated) on top of the wing and a relatively higher static pressure below. The pressure differential then pushes the wing up towards the lower pressure area, i.e., LIFT. To increase the lift, the wing is tilted upward in relation to the oncoming air (relative wind) to increase the deflection of air. Relative wind during flight is the direction of the airflow in relation to the wing as it moves through the air. The angle at which the wing meets the relative wind is called the angle of attack. (Figure 2-1)

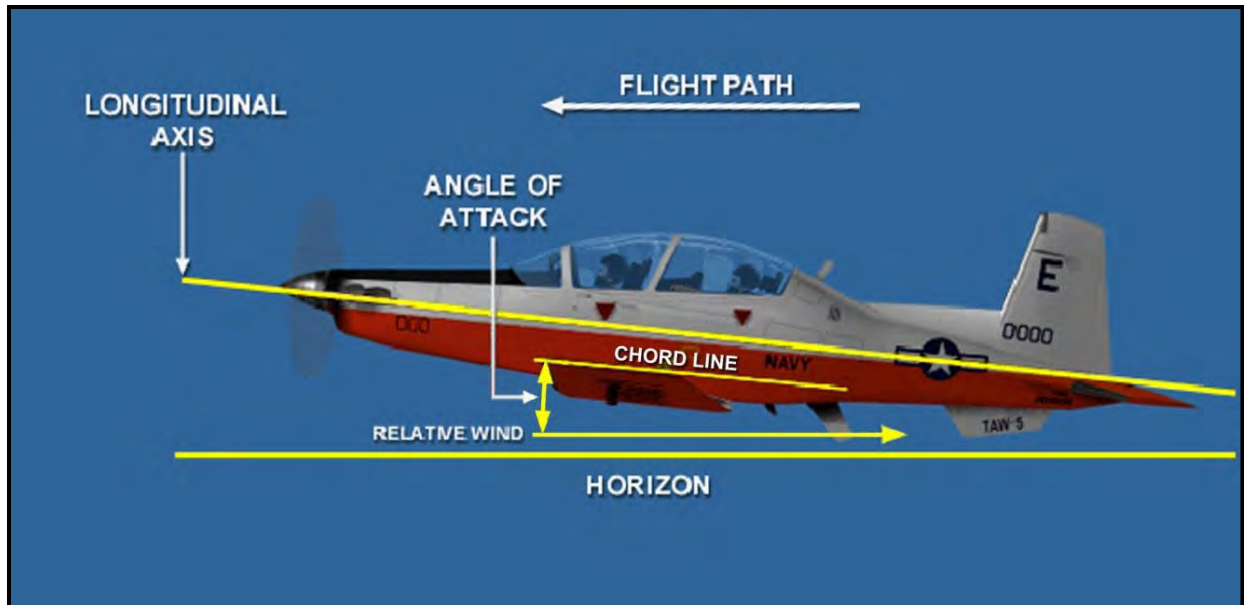

Figure 2-1 Angle of Attack

If the airplane's speed is too slow, the angle of attack required will be so large that the air can no longer follow the upper curvature of the wing. This results in a swirling, turbulent flow of air over the wing and "spoils" the lift. Consequently, the wing stalls. On most types of airplanes, this critical angle of attack is about 15-20 units.

When the propeller rotates, it provides the force to pull the airplane forward. This forward motion causes the airplane to act on the air to produce lift. The propeller blades, just like a wing, are curved on one side and straight on the other side. Hence, as the engine rotates the propeller, forces similar to those of the wing create "lift" in a forward direction. This is called thrust.

Up to this point, the discussion has related only to the "lifting" force. Before an understanding of how an airplane flies is complete, other forces must be discussed.

2. **Gravity.** While the airplane is propelled through the air and sufficient lift is developed to sustain it in flight, there are certain other forces acting at the same time. Every particle of matter, including airplanes, is attracted downward towards the center of the earth by gravitational force. The amount of this force on the airplane is measured in terms of weight. If the airplane is to keep flying, lift must overcome its weight or gravitational force.

3. **Drag.** Another force that constantly acts on the airplane is drag. Drag is the resistance created by air particles striking and flowing around the airplane when it is moving through the air. Aircraft designers constantly try to streamline wings, fuselages and other components to reduce the rearward force of drag as much as possible. The portion of drag caused by form resistance and skin friction is termed parasite drag, since it is not the result of the production of lift.

2-2 T-6B AERODYNAMICS AND FLIGHT CONTROLS

A second part of the total drag force is caused by the wing's lift. As the wing deflects air to produce lift, the total lift force is not exactly vertical, but is tilted slightly rearward. This means that it causes some rearward drag force. This drag is called induced drag, and is the price paid to produce lift. The larger the angle of attack, the more the lift force on the wing tilts towards the rear and the larger the induced drag becomes. To give the airplane forward motion, thrust must overcome drag.

In a steady flight condition (no change in speed or flight path), forces that oppose each other are also equal to each other and are always present. That is, lift equals weight, and thrust equals drag.

4. **Centrifugal Force.** Still yet another force that frequently acts on the airplane is centrifugal force. However, this force occurs only when the airplane is turning or changing the direction (horizontally or vertically) of the flight path. Another of Newton's laws of energy states that "a body at rest tends to remain at rest, and a body in motion tends to remain moving at the same speed and in the same direction . . ." Thus, to make an airplane turn from straight flight, a sideward inward force must act upon it. The tendency of the airplane to keep moving in a straight line and outward from a turn is the result of inertia and it produces centrifugal force. Therefore, some impeding force is needed to overcome centrifugal force so that the airplane moves in the desired direction. The lift of the wings provides this counteracting force when the airplane's wings are banked in the desired direction. Refer to the section on Turns in chapter three.

Since the airplane is in a banked attitude during a properly executed turn, the pilot will feel the centrifugal force by increased seat pressure, rather than the feeling of being forced to the side as is experienced in a rapidly turning automobile. The amount of force (G force) felt by seat pressure depends on the angle of bank. The pilot will, however, be forced to the side of the airplane (as in an automobile) if a turn is improperly made and the airplane is made to slip or skid.

5. **Yaw Forces.** One other force which affects the aircraft during certain conditions of flight and which will be frequently referred to in the discussions on various flight maneuvers is torque effect or "left turning tendency." It is probably one of the least understood forces that affect an aircraft in flight. Torque effect is the force which causes the airplane to have a tendency to swerve (yaw) to the left, and is created by the clockwise rotation of the engine and the propeller. There are four factors that contribute to this yawing tendency:

- a. Torque reaction to the engine and propeller.
- b. The propeller's gyroscopic effect.
- c. The corkscrewing effect of the propeller slipstream.
- d. The asymmetrical loading of the propeller (P-factor).

It is important that pilots understand why these factors contribute to torque effect.

- a. **Torque reaction.** (Figure 2-2) Torque reaction in a propeller-driven aircraft acts opposite the direction of propeller rotation. In the case of the T-6B, the aircraft tends to roll to the left as a result of torque when power is increased, and the aircraft tends to roll right when power is reduced. Rudder and the TAD are the primary means for compensating for engine torque.

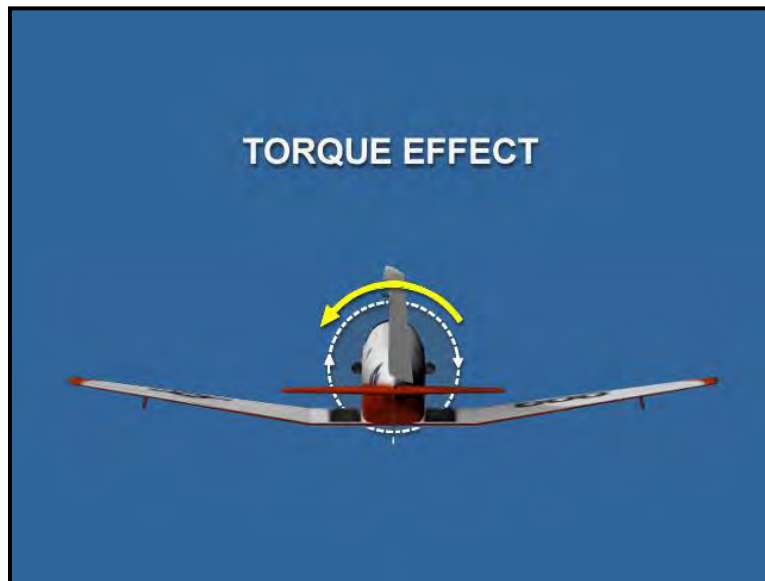

Figure 2-2 Torque Effect

- b. **Gyroscopic Effects.** (Figure 2-3) Gyroscopic reactions are called gyroscopic precession. This occurs when a force is applied to displace a spinning mass such as the propeller or, in the case of a spin, the aircraft as a whole. Gyroscopic precession causes an applied force to act in a plane 90° from that in which it was applied (it is applied in the same direction as the rotation). The effect of gyroscopic precession depends on the rate of movement about the pitch or yaw axis. Increased rotation rates tend to increase the effect. This explains why a pilot, who abruptly corrects aircraft deviations (pitch, bank, and yaw), ends up frustrated with the adverse effects of precession. The relatively large propeller on the T-6B and high revolutions per minute (rpm) result in more precession effect than an aircraft with a lighter, smaller propeller turning at slower rpm. Typical reactions from a clockwise-turning propeller (as viewed from the pilot's seat) include:
 - i. If the nose is yawed to the left, the nose tends to pitch up.
 - ii. If the nose is yawed to the right, the nose tends to pitch down.
 - iii. If the nose is pitched down, a left yaw tends to develop.
 - iv. If the nose is pitched up, a right yaw tends to develop.

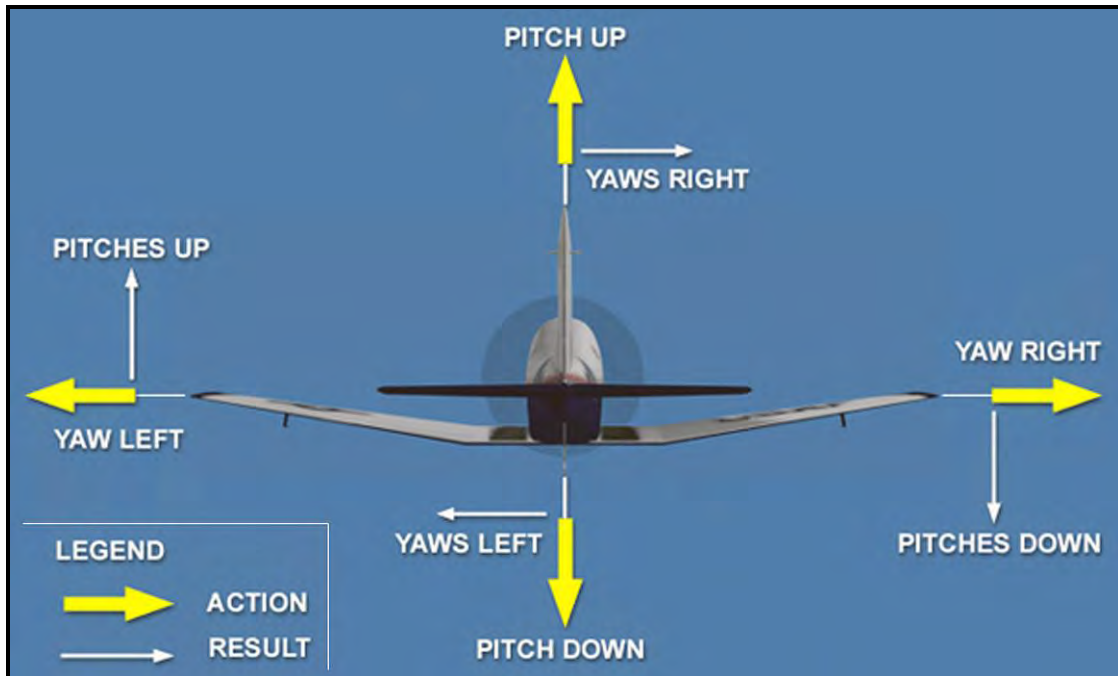

Figure 2-3 Gyroscopic Effects

- c. **Slipstream Effect** (Figure 2-4). The thrust generated by the rotation of the propeller induces a phenomenon called corkscrew slipstream effect. Specifically, the rotating prop produces a helical (or corkscrew) shaped air stream about the longitudinal axis. This slipstream strikes the wing root, fuselage, and tail surfaces with a constant high-energy force proportional to power setting and airspeed. The addition of power increases airflow over the tail surfaces and makes them more effective at slow speeds. In the T-6B, the corkscrew slipstream induces a slightly higher angle of attack (AOA) on the left wing root and left tail surfaces, and slightly lowers AOA on the right wing root and right tail surfaces. This causes the aircraft to yaw to the left when power is increased, and requires right rudder input to counter the yaw and maintain coordinated flight. As the power is increased by moving the power control lever (PCL) forward with the left hand, the right foot must move forward to counter the yaw that is induced to the left. The amount of rudder movement is proportional to the amount and rate of PCL movement. The amount and rate of rudder movement can be determined by looking out the front of the aircraft and using the rudder to keep the nose from swinging either left (too little rudder application) or right (too much rudder application). A power reduction has the opposite effect, requiring left rudder to maintain coordinated flight.



Figure 2-4 Slipstream Effect

- d. **P-Factor** (Figure 2-5). P-factor is another effect of the propeller. It is caused by AOA being higher on the downward moving propeller blade than on the upward moving propeller blade. This occurs when the aircraft's thrust line is above the free air stream relative wind or at low speeds and high angles of attack with power-on. This moves the aerodynamic center of the propeller to the right of the shaft on a clockwise-rotating propeller, causing the aircraft to yaw left as AOA or power is increased. This is why increasing right rudder is required to maintain coordinated flight as angle of attack is increased on the aircraft, such as in a pull-up for an over-the-top aerobatic maneuver. As the airspeed decreases and the AOA increases, the aerodynamic center of the propeller shifts to the right and right rudder is required to keep the aircraft in coordinated flight. The opposite is true when the thrust line is below the free air stream relative wind. The upward-moving propeller blade then has a higher angle of attack than the downward-moving blade. This moves the aerodynamic center of the propeller to the left of the shaft on a clockwise-rotating propeller, causing the aircraft to yaw to the right and requires left rudder to maintain coordinated flight. A right yawing situation seldom occurs since pushing over to the point of shifting the thrust line below the free air stream relative wind is rarely warranted.

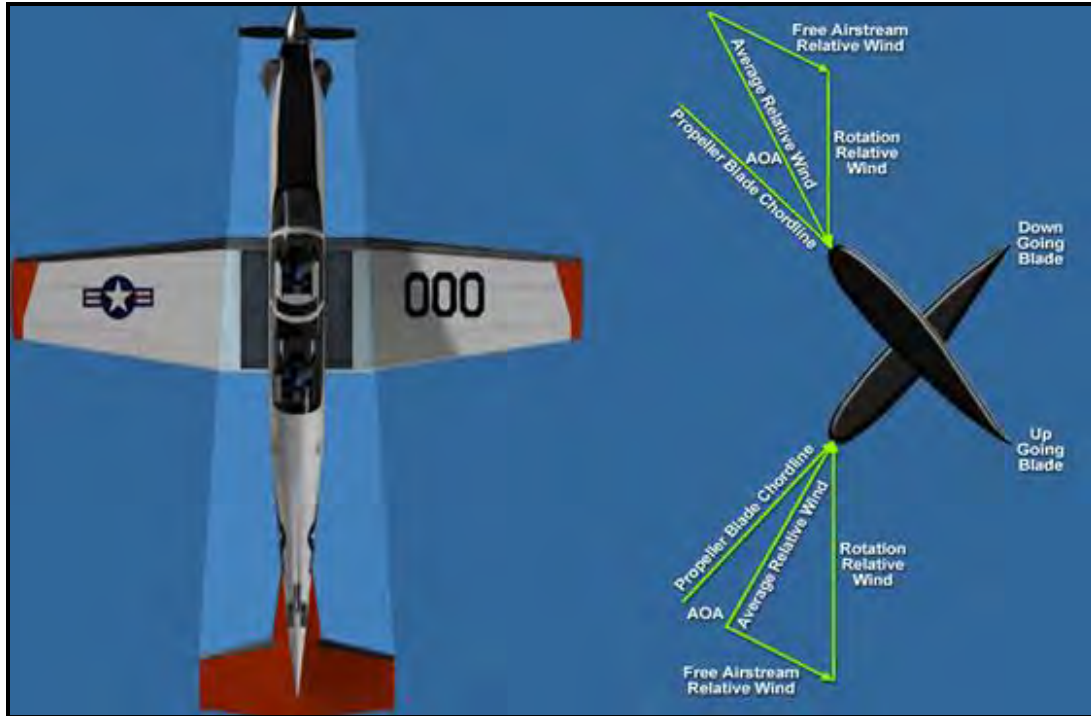

Figure 2-5 P-Factor

202. STABILITY AND CONTROL

Most types of naval aircraft have been designed with satisfactory handling qualities in addition to adequate performance. In particular, the T-6B is stable enough to maintain uniform flight conditions, recover from disturbances (such as turbulence), and minimize pilot workload. It has sufficient controllability to achieve the desired performance. However, there are certain conditions of flight which produce the most critical requirements of stability and control. These conditions must be understood and respected to accomplish safe and efficient operation of the aircraft.

1. **Static Stability.** Besides being supported in flight by lift and propelled through the air by thrust, an airplane is free to revolve or move around three axes. These axes may be thought of as axes around which the airplane revolves much like a wheel does. Each axis is perpendicular to the other two and all three intersect at the airplane's center of gravity (CG). The point around which the airplane's weight is evenly distributed or balanced is considered the CG of the airplane. Figure 2-6 depicts the axes about which the aircraft rotates.

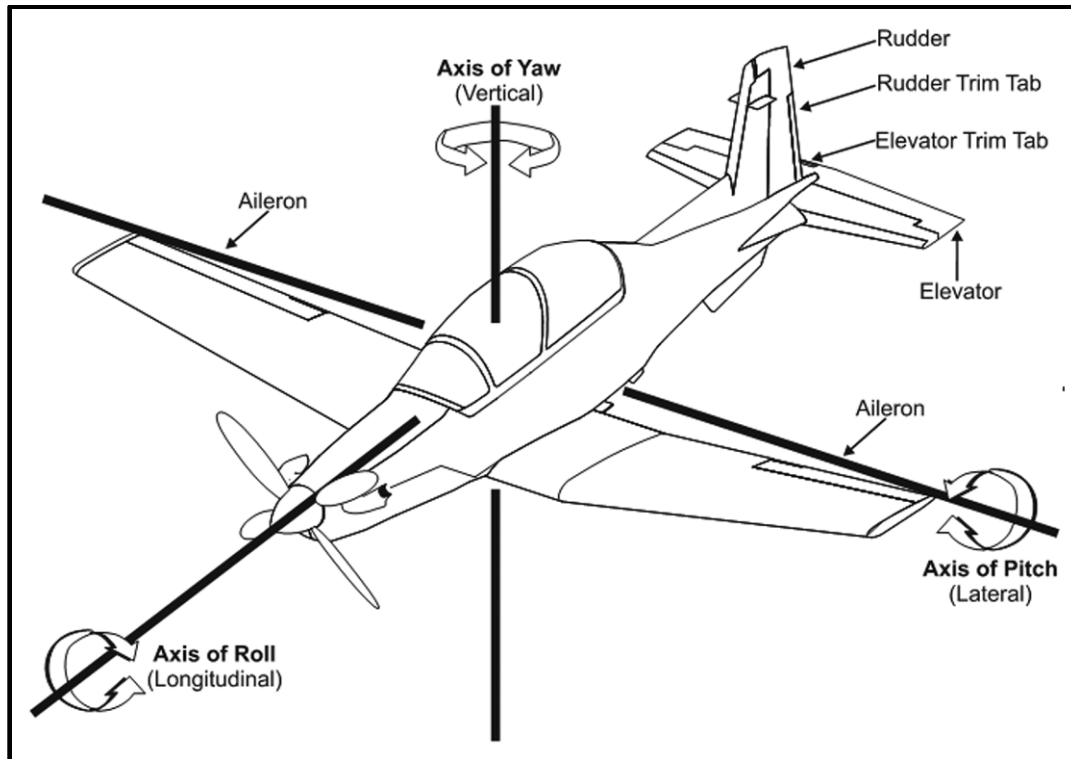

Figure 2-6 Aircraft Axes

An aircraft trimmed for steady flight is in a state of equilibrium. In other words, the sum of all the forces and moments is zero. Displacement from this position by some outside force, such as a gust of turbulence, creates an unbalance and causes the aircraft to demonstrate an initial tendency. This tendency will be to (a) return, (b) be displaced further, or (c) remain in the new attitude or position. This initial tendency is known as static stability. If the aircraft tends to move back in the direction of its trimmed attitude, it is said to be statically stable or to have positive static stability. If the aircraft continues to move away from trimmed equilibrium, it is statically unstable or it has negative stability. An aircraft that stays in its displaced attitude, neither moving positively nor negatively, is said to be neutrally stable or neutrally statically stable (Figure 2-7).

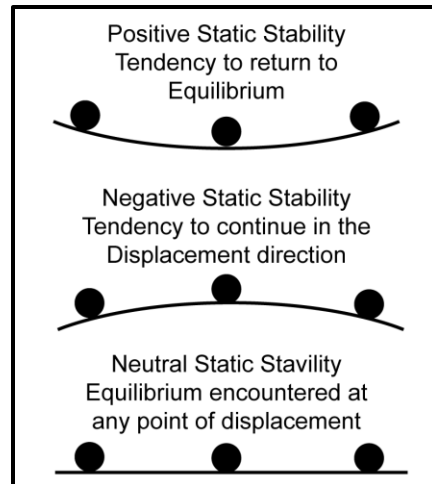

Figure 2-7 Static Stability

2. **Dynamic Stability.** Dynamic stability is the movement of an aircraft with respect to time. If an aircraft has been disturbed from its equilibrium position and the maximum displacement decreases with time, it is said to have positive dynamic stability. If the maximum displacement increases with time, it is said to have negative dynamic stability. If the displacement remains constant with time, it is said to have neutral dynamic stability. Both static and dynamic stability are usually desired in an airplane.

Static stability does not guarantee that an airplane will also be dynamically stable; however, the airplane must first be statically stable before it will oscillate at all and, thus, exhibit any kind of dynamic stability. Possible cases of stability can be summarized in Figure 2-8.

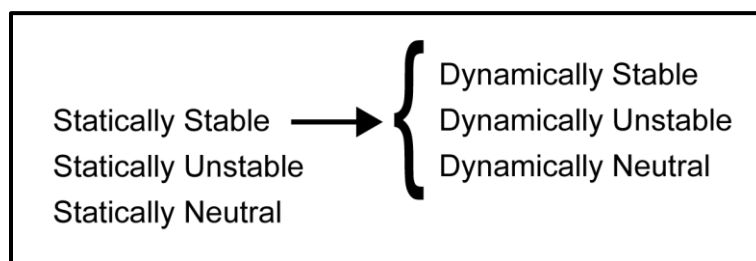

Figure 2-8 Cases of Stability

In addition to positive static stability, the T-6B has positive dynamic stability. Over a period of time, it will tend to return to most conditions for which it was trimmed.

Let us again consider the ball in the saucer shown in Figure 2-7. If you move the ball to the displaced (dotted) position and then let go, it will not go directly to the equilibrium point and stop. Rather, its inertia will carry it well past the bottom and up the other side. As gravity overcomes its inertial acceleration, it rolls back the other way towards the original displacement point until it succumbs again to gravity. This motion could go on indefinitely if there were no friction present between the ball and the dish. Eventually, friction will reduce the momentum of

the ball sufficiently so that it finally settles down once again to the bottom of the dish. A pendulum that is pushed to one side and released displays the same action. The resulting motion is an oscillation (movement from one side of the equilibrium point to the other) until friction damps out the motion.

Your instructor will demonstrate the stability characteristics of the T-6B aircraft by trimming for straight and level balanced flight. He will then place the aircraft in various attitudes and permit the aircraft to return to straight and level balanced flight, demonstrating the necessity and ease of proper use of trim. As discussed earlier in this chapter, the T-6B is capable of equilibrium flight in all airspeeds and configurations that you will encounter. That is, for all changes in power, airspeed, and configurations, the aircraft is able to maintain a "hands-off" straight and level balanced flight condition, but will require a ***CHANGE IN TRIM SETTING*** for those changes. Further discussion on the use of trim will occur later in this chapter.

An aircraft is said to be trimmed if all moments in pitch, roll, and yaw are equal to zero. The establishment of equilibrium at various conditions of flight is the function of the controls and will be accomplished by pilot effort and trim tabs. Pilot effort is necessary to establish equilibrium conditions and trim tabs will be used to hold the desired conditions (i.e., reduce control pressure). During training, trim will be of extreme importance and trimming rapidly and properly will become a habit. The necessity to trim the T-6B cannot be overemphasized. When all of the pilot's energy is consumed fighting the controls, little is left over for flying the aircraft and maintaining situational awareness.

3. **Control.** Control is concerned with the maneuverability of the aircraft. Although the T-6B aircraft is "inherently stable" due to its positive and static and dynamic stability, it is not so stable as to inhibit aircraft maneuverability. Since the T-6B is a primary trainer, it was designed to have controls capable of aerobatic flight, yet not so sensitive as to make the aircraft difficult to control or allow aircraft limits to be easily exceeded. Generally speaking, control forces are highest in the directional axis (ailerons). The magnitude of these forces varies depending on the airspeed, trim setting and the amount of deflection. At higher speeds, controls become difficult to deflect due to higher dynamic pressure impinging on the control surfaces. Although the higher dynamic pressure makes the controls more effective, resulting in a greater aircraft reaction for a given control deflection, the forces required to obtain that control deflection are higher. Trim setting affects control forces in that the further the aircraft is flown from its trimmed airspeed, the greater the forces required (in all axes) to maintain balanced flight conditions. These forces serve as physical cues to the pilot that the aircraft has deviated from its trimmed airspeed.

203. STALLS

In earlier discussions it was shown that an airplane would fly as long as the wing is creating sufficient lift to counteract the load imposed on it. When the lift is completely lost the airplane stalls. Remember that the direct cause of every stall is an excessive angle of attack. There are a number of flight maneuvers which may produce an increase in the angle of attack, but the stall does not occur until the angle of attack becomes excessive.

It must be emphasized that the stalling speed of a particular airplane is not a fixed value for all flight situations. However, a given airplane will always stall at the same angle of attack regardless of airspeed, weight, load factor, or density altitude. Each airplane has a particular angle of attack where the airflow separates from the upper surface of the wing and the stall occurs. Each airplane has only one specific angle of attack where the stall occurs. The airplane can be stalled in straight and level flight by flying too slowly. As the airspeed is being decreased, the angle of attack must be increased to retain the lift required for maintaining altitude. The slower the airspeed becomes, the more the angle of attack must be increased. Eventually an angle of attack is reached which will result in the wing not producing enough lift to support the airplane and it will start settling. If the airspeed is reduced further, the airplane will stall since the angle of attack has exceeded the critical angle and the airflow over the wing is disrupted.

In naval aviation, there is great importance assigned to precise control of an aircraft at high angle of attack conditions. Safe operation in carrier aviation demands the ultimate in precision flying at low airspeed. The aerodynamic lift characteristics of an airplane must be fully understood by the Student Naval Aviator as well as the seasoned "fleet pilot" for obvious safety reasons. Additionally, mission requirements and their execution may depend on the pilot's own capabilities and grasp of these basic concepts.

During flight (maneuvers, landing approach, takeoff, etc.), the airplane will stall ***IF THE CRITICAL ANGLE OF ATTACK IS EXCEEDED***. The airspeed at which stall occurs will be determined by weight, load factor, altitude, and configuration, but the stall angle of attack remains unaffected. At any particular altitude, the indicated stall speed is a function of weight and load factor. An increase in altitude will produce a decrease in density and an increase in true airspeed. Also, an increase in altitude will alter compressibility and airflow viscosity, which will cause the indicated stall speed to increase.

Modern airplanes are characterized by having a large percentage of their maximum gross weight as fuel. Most Navy inventory aircraft carry 25-40% of their total gross weight in this manner. Hence, the gross weight and stall speed of the airplane can vary considerably throughout the flight. A general "rule of thumb" is that a 2% change in weight will cause a 1% change in stall speed.

Load Factor/Centrifugal Force. Turning flight and maneuvers produce an effect on stall speed, which is similar to the effect of weight. The stalling speed of an airplane is higher in a level turn than in straight and level flight. This is because centrifugal force is added to the airplane's weight, and the wing must produce sufficient additional lift to counterbalance the load imposed by the combination of centrifugal force and weight. In a turn, the necessary additional lift is acquired by applying back pressure to the elevator control. This increases the wing's angle of attack, and results in increased lift. As stated earlier, the angle of attack must increase as the bank angle increases to counteract the increasing load caused by centrifugal force. If at any time during a turn the angle of attack becomes excessive, the airplane will stall. Thus, the aircraft in a steady turn still develops lift greater than weight, but experiences increased stall speeds due to load factor increases. This fact emphasizes the need to avoid steep turns at low airspeeds - a flight condition common to stall/spin accidents. (Refer to NATOPS V_n Diagram.)

It must be reemphasized here that low speed is not necessary to produce a stall. The wing can be brought into an excessive angle of attack at any speed. For example, take the case of an airplane which is in a dive with an airspeed of 200 KIAS, when suddenly the pilot pulls back sharply on the elevator control. Because of gravity and centrifugal force, the airplane could not immediately alter its flight path, but would merely change its angle of attack abruptly from quite low to very high. Since the flight path of the airplane, in relation to the oncoming air, determines the direction of the relative wind, the angle of attack is suddenly increased, and the airplane will quickly reach the stalling angle at a speed much greater than normal stall speed.

The primary purpose of high lift devices (i.e., flaps, slats, and slots) is to increase the coefficient of lift and reduce the stall speed for an airplane. Therefore, flap extension increases the total lift available and reduces the angle of attack for any given lift coefficient.

At this point we should examine the action of the airplane during a stall. In our earlier discussion of pitching (longitudinal) stability, we learned that to balance the airplane aerodynamically, the center of lift is normally located aft of the center of gravity. It should be noted that although this airplane is inherently "nose heavy," downwash on the horizontal stabilizer counteracts this condition. It can be seen then, that at the point of stall when the upward force of the wing's lift and the downward tail force cease, an unbalanced condition exists. This allows the airplane to pitch down abruptly, rotating about its center of gravity. During this nose down attitude, the angle of attack decreases and the airspeed again increases; hence, the smooth flow of air over the wing begins again, lift returns, and the airplane is again flying. However, considerable altitude may be lost before this cycle is complete.

The associated loss of altitude and control response in the stalled configuration has meant the lives of both students and seasoned naval aviators. A stall never checks anyone's logbook or qualifications before it decides to happen. Therefore, it is important to remember that the stall is not merely a precision maneuver, but an actual situation into which you may inadvertently fly while concentrating on some other aspect of your flying.

204. PRIMARY FLIGHT CONTROLS

To maneuver an aircraft, you will learn to control its movement about its lateral, longitudinal, and vertical axes (Figure 2-9). This is accomplished by the use of the flight controls (elevators, ailerons, and rudder), which can be deflected from their neutral position into the flow of air as the aircraft moves forward. In flight, the controls have a natural "feel" due to the force of the airflow around them. With this in mind, the student should think of exerting force against this pressure or resistance, not of moving the flight controls.

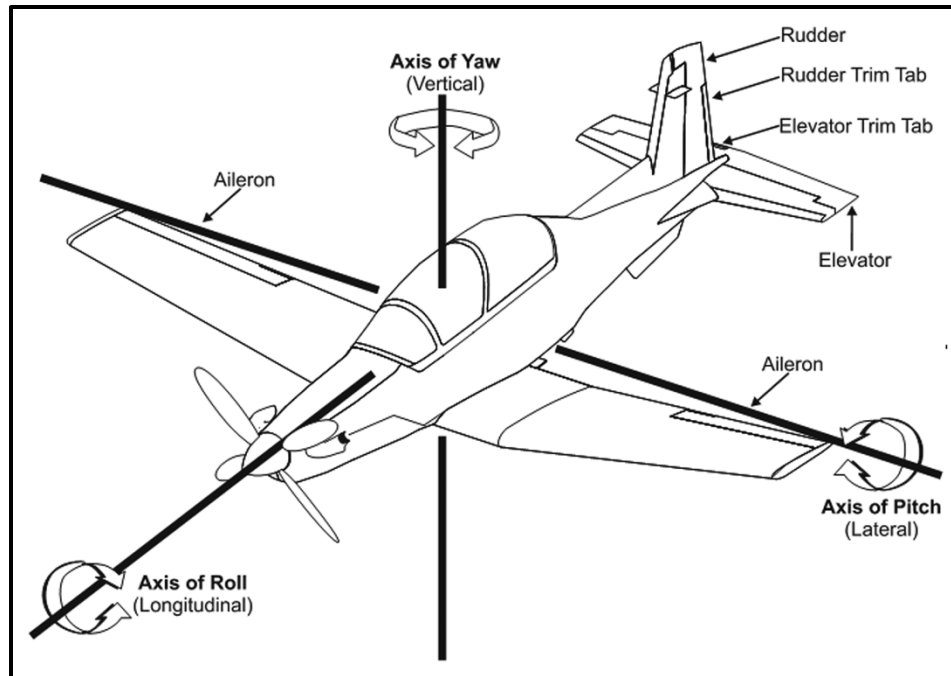

Figure 2-9 Aircraft Axes

1. **Elevators.** The elevators control the aircraft's movement about its lateral axis. They form the rear part of the horizontal stabilizer, are free to be moved up and down by the pilot, and are connected to a control stick in the cockpit by means of cables and pulleys. Applying forward pressure on the stick causes the elevator surfaces to move downward. The flow of air striking the deflected elevator surfaces exerts an upward force, pushing the aircraft's tail upward and the nose downward. Conversely, exerting back pressure on the control causes the elevator surfaces to move up, exerting a downward force to push the tail downward and the nose upward. In effect, the elevators are the angle-of-attack (AOA) control. When back pressure is applied on the control, the tail lowers and the nose rises, thus increasing the wing's AOA and lift.

2. **Ailerons.** The ailerons control the aircraft's movement about its longitudinal axis (Figure 2-10). There are two ailerons, one at the trailing edge of each wing, near the wingtips. They are movable surfaces hinged to the wing's rear spar and are linked together by cables so that when one aileron is deflected down, the opposite aileron moves up. The ailerons are statically mass balanced with weights installed on the leading edges of each aileron.

The two wings produce differences in the lift that actually turn the aircraft. To obtain the horizontal component of lift required to pull the aircraft in the desired direction of turn, apply lateral control stick force in that direction. When the pilot applies pressure to the left on the control stick, the right aileron surface deflects downward and the left aileron deflects upward. The force exerted by the airflow on the deflected surfaces raises the right wing and lowers the left wing. This happens because the downward deflection of the right aileron changes the wing camber and increases the AOA and lift on that wing. Simultaneously, the left aileron moves upward and changes the effective camber, resulting in a decreased AOA and less lift. Thus, decreased lift on the left wing and increased lift on the right causes the aircraft to bank to the left.

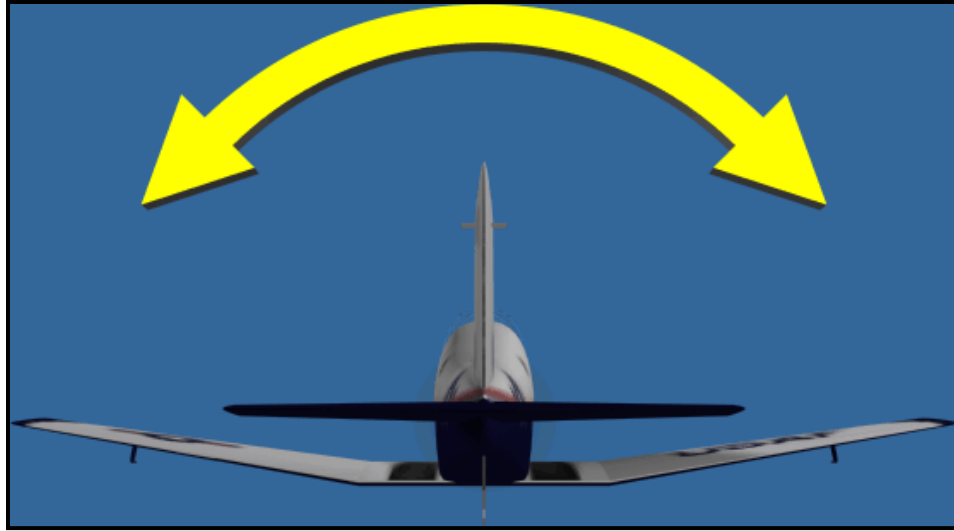

Figure 2-10 Aileron Control

3. **Adverse Yaw.** (Figure 2-11): Since the downward deflected aileron produces more lift, it also produces more drag, while the opposite aileron has less lift and less drag. This added drag attempts to pull or veer the airplane's nose in the direction of the raised wing; that is, it tries to turn the airplane in the direction opposite to that desired. This undesired veering is referred to as adverse yaw.

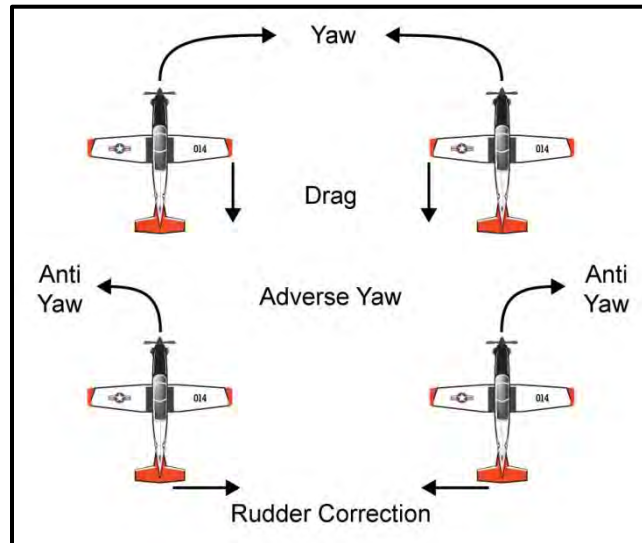

Figure 2-11 Adverse Yaw

To demonstrate this in flight, an attempt can be made to turn to the right without using the rudder pedals. As right aileron pressure is applied, the airplane rolls into a right bank and tries to turn to the right. But the adverse yaw, or the drag on the downward deflected left aileron, pulls the airplane's nose to the left. The airplane banks, but it turns hesitantly and sideslips. This is undesirable and corrective action should be taken by applying right rudder pressure.

When right rudder pressure is applied simultaneously with right aileron pressure, it keeps the airplane from yawing opposite to the desired direction of turn. In fact, the rudder must be used because the ailerons were used. Coordinated use of the rudder with the ailerons in a turn will counteract the effects of adverse yaw.

Adverse yaw is an undesirable effect, and is most apparent at low speeds and extreme control-surface deflections. At faster airspeeds, adverse yaw becomes less apparent and may be unnoticeable. When accomplishing slow flight, watch closely for the effects of adverse yaw in the turn. Your instructor can share methods on how to appropriately use the rudder while initiating a turn to counter adverse yaw effects.

4. **Rudder.** The rudder controls the aircraft's movement about its vertical axis. This motion is called yaw. Like the other primary control surfaces, the rudder is a movable surface hinged to a fixed surface; in this case to the vertical stabilizer. Left and right rudder pedals control rudder movement. Its action is much like that of the elevators, except the motion is side to side instead of up and down. When the rudder is deflected to one side, it protrudes into the airflow, causing a horizontal force to be exerted in the opposite direction. This pushes the tail of the aircraft in that direction and yaws the nose in the desired direction. For example: when the rudder is deflected to the left, it protrudes into the airflow on the left side of the tail, causing a horizontal force to be exerted on the tail to the right. This pushes the tail of the aircraft to the right and yaws the nose to the left.

The primary purpose of the rudder in flight is to counteract the effect of adverse yaw and to help provide directional control of the airplane. In flight, the rudder does not turn the airplane; instead, the force of the horizontal component of wing lift turns the airplane when the wings are banked. As in the demonstration of turning by use of ailerons alone, this can be verified by flying straight and level, and then, after taking the hands off the control stick, trying to turn to the right by applying right rudder pressure only. At first it may seem to work pretty well. The airplane will turn to the right, but it will also skid to the left (a skid in a turn is an unbalanced flight condition caused by insufficient angle of bank for a given radius of turn). Since the airplane possesses inherent stability, it will tend to stop the skid by banking itself to the right.

If the pilot were now to neutralize the rudder, only a shallow banking turn would result. However, inasmuch as the purpose of this demonstration is to make a turn using only the rudder, continue to hold right rudder pressure. Since the airplane is slightly banked to the right, the rudder will force the nose of the airplane downward to the right. The reason for this is that yawing is the only movement the rudder can produce. As a result, the nose yaws downward, the airspeed increases, and the airplane starts losing altitude. At the same time, the airplane, being stable, attempts to stop the increased skidding by banking more steeply. The more steeply it banks, the more the nose is yawed downward by the right rudder action. The net result of holding rudder alone is a descending spiral unless back elevator pressure is applied. Thus, it can be seen that rudder alone cannot produce a balanced turn. Coordinated application of aileron, rudder, and elevator pressure will produce a balanced flight condition.

On the ground, the T-6B rudder pedals manipulate the nose wheel steering (if engaged), which is used to directionally control the aircraft while taxiing. Taxiing will be discussed in greater detail in Chapter Four, Ground Procedures.

5. **Primary Control Application.** The following will always be true in controlled flight, regardless of the airplane's attitude in relation to the earth:
- a. When backpressure is applied to the elevator control, the airplane's nose rises in relation to the pilot.
 - b. When forward pressure is applied to the elevator control, the airplane's nose lowers in relation to the pilot.
 - c. When right pressure is applied to the aileron control, the airplane's right wing lowers in relation to the pilot.
 - d. When left pressure is applied to the aileron control, the airplane's left wing lowers in relation to the pilot.
 - e. When pressure is applied to the right rudder pedal, the airplane's nose moves to the right in relation to the pilot.
 - f. When pressure is applied to the left rudder pedal, the airplane's nose moves to the left in relation to the pilot.

205. SECONDARY FLIGHT CONTROLS - TRIM DEVICES

The secondary flight controls include electrically actuated pitch/roll/yaw trim systems and a rudder trim aid device (TAD). The secondary flight controls are used for trimming and balancing the aircraft in flight and to reduce the force required to actuate the primary flight control surfaces.

Trimming the aircraft is an essential skill for you to master and its importance is often overlooked by fledging aviators. When an aircraft's flight conditions (attitude, power, airspeed, loading and configuration) are changed, the control pressures required to maintain the desired conditions are affected by the resulting changes in aerodynamic forces. The T-6B is equipped with systems that allow you to trim the aircraft for balanced flight in all axes.

1. **Trim System and Switches.** The elevator and aileron trim are utilized by a thumb-actuated switch (Figure 2-12) at the top of the control stick (fore/aft for elevator trim and laterally for aileron trim). The rudder trim switch is located on the forward side of the power control lever (PCL). To trim, deflect the trim switch in the opposite direction as the applied flight control force until that force is relieved. When perfectly "trimmed," you can release flight control pressures (momentarily) and the aircraft will remain in its current balanced state. The Trim Interrupt button on the control stick will remove electrical power from the trim devices and is used during certain trim malfunctions. The general sequence for trimming the aircraft is:

Rudder, Elevator and then Aileron. The rudder trim is usually first because a correction for yaw precipitates a change in the trim setting for pitch and roll. Consequently, not trimming the rudder first will generally cause you to go back and re-trim the elevator and aileron after trimming the rudder.



Figure 2-12 Control Stick

2. **Rudder Trim:** an electromechanical actuator located in the vertical stabilizer, which drives an anti-servo trim tab on the trailing edge of the rudder provides rudder trim. Reference the balance ball of the turn and slip indicator to help determine the proper direction of rudder and rudder trim pressure. For example, if the ball is out to the right, the nose is actually out to the left and you are in unbalanced flight. Smoothly apply right rudder pressure (“Step On The Ball”) to regain balanced flight. Then smoothly apply right rudder trim until you relieve the rudder pressure you are holding. If you have trimmed properly, the ball should stay in the center and you should feel as if you are flying straight and level.

3. **TAD:** the rudder TAD of the T-6B assists in trimming about the yaw axis of the aircraft. The inputs to the TAD include engine torque, altitude, airspeed, and pitch rate. Based on these inputs, the TAD sends a signal to the rudder trim actuator physically moving the trim tab surface to a computed position. Although the TAD is effective at approximating a valid rudder trim position, it by no means replaces the need to appropriately trim the rudder, especially during rapid accelerations and large power changes.

Remember, any pilot-actuated electric rudder trim inputs are additive to the trim input the TAD commands. Thus, a good method during minor trim changes is to allow the TAD to complete its trim cycle, then make fine adjustments as necessary. Loss of the TAD in flight does not affect the overall controllability of the aircraft and its loss would minimally impact most training missions.

4. **Elevator Trim:** elevator trim is provided by an electromechanical actuator which drives a tab surface on the right side of the elevator. To trim the aircraft nose attitude, first move the stick to position the nose for the attitude you desire in relationship to the horizon. As the fore/aft stick force increases, maintain the desired nose attitude and apply elevator trim in the opposite direction as the control pressure until it is relieved. Always use a light grip on the stick so as to “feel” the pressure. “Finger-tip control” is the key to smooth flying.

5. **Aileron Trim:** the aileron trim is utilized much like the elevator trim but about the longitudinal, or roll, axis of the aircraft. Interestingly, unlike the other two trim systems that utilize trim tab surfaces on their trailing edges (rudder and elevator), aileron trim in the T-6B is accomplished by physical movement of the ailerons. Ground adjustable trim tabs are installed on the trailing edge of each aileron to allow maintenance personnel to adjust the “neutral” setting. Aileron trim is only necessary if, after the rudder is trimmed, the aircraft tends to roll to one side.

206. TRIM REQUIREMENTS - RUDDER/ELEVATOR

Acceleration	LEFT/DOWN
Deceleration	RIGHT/UP
Power Addition	RIGHT/DOWN
Power Reduction	LEFT/UP

When airspeed is increased (with power unchanged), the nose will have a tendency to rise and the aircraft will yaw slightly to the right; consequently, we need to add left (rudder) and down (nose down) trim. If power is unchanged and airspeed is reduced, we see from the box above that right rudder trim and up elevator trim is needed. If airspeed is constant and power is increased, then right rudder trim and down elevator trim is needed. If power is reduced with airspeed constant, then left rudder trim and up elevator trim are necessary.

Aside from these four basic scenarios, many flight maneuvers combine two of the “rules” simultaneously. For example, when initiating a 180 knot climb from normal cruise (200 knots, level), you add power, raise the nose, and decelerate. In this case, right rudder trim is required for both the power addition and deceleration. However, the requirement conflicts on what to do with the elevator (power addition = nose down/deceleration = nose up). In this example, trim “nose up” because, generally speaking, in opposing situations such as this one, airspeed will have a greater and more lasting effect on the elevator and rudder trim. Therefore, as a common trim rule, *“Airspeed trumps Power.”*

207. PERFORMANCE

Remember this simple formula: ***POWER + ATTITUDE = PERFORMANCE***

Most early basic air work problems result from the inability to properly see and control the aircraft's attitude, in correlation to the power applied by the engine. Only after you master proper attitude control will you begin to develop solid basic flying skills.

Coordinated use of all controls is very important in any turn. Applying aileron pressure places the aircraft in the desired angle of bank (AOB), while simultaneous application of rudder pressure is required to counteract the resultant adverse yaw. During a turn, the AOA must be increased by adding back-stick pressure (increasing elevator deflection) to compensate for the loss of lift due to bank. Thus, the steeper the turn, the more back elevator pressure is needed to maintain level flight, accompanied by a corresponding increase in G load. Varying greatly among different flight regimes, deflection of the control surfaces will allow you to reach the desired result.

When using the rudder pedals, pressure should be applied smoothly and evenly by pressing with the ball of one foot just as when using the brakes of an automobile. The rudder pedals are interconnected and act in opposite directions; when pressure is applied to one pedal, pressure on the other must be relaxed proportionally. For positioning, comfortably rest the balls of your feet against the lower portion of the rudder pedals while supporting the weight of your feet on the cockpit floor. The pedals should be adjusted so that full throw is available with a slight flex in the knee.

208. POWER CONTROL LEVER

The PCL controls the power output of the engine (Figure 2-13). This power, transmitted through the propeller, produces thrust. As discussed in the previous chapter, this thrust will propel the aircraft through the air, developing lift. When sufficient power is combined with the appropriate angle of attack, the desired performance is obtained.

Moving the PCL forward increases power; moving it aft decreases power. If a constant airspeed is maintained with adjustments in the attitude relative to the horizon, a variation in power will control the gain or loss of altitude. This concept of control establishes a basic fundamental of the mechanics of any powered flight.

The PCL should be operated firmly but smoothly. You will learn to set the desired power with your peripheral vision and then go back and fine-tune the power as required for a particular maneuver. Occasionally, check to see that the desired power setting is still in fact set.



Figure 2-13 PCL

CHAPTER THREE FUNDAMENTAL FLIGHT CONCEPTS

300. INTRODUCTION

This section discusses and explains the fundamental flight maneuvers upon which all flying tasks and procedures are based. In learning to fly, as in any learning process, fundamentals must be mastered before the more advanced phases can be learned.

301. FUNDAMENTAL FLIGHT MANEUVERS

Maneuvering of the airplane is generally divided into four flight fundamentals:

- Straight and level flight
- Turns
- Climbs
- Descents

All controlled flight consists of any one or a combination of these basic maneuvers. Proper control of an airplane's attitude is the result of the pilot knowing when and how much to change it, and then smoothly making the required correction. When flying by reference to objects outside the airplane, the effects of the pilot's control application on the airplane's flight attitude can be seen by observing the relationship of the position of some portion of the airplane to the outside references.

At first, control of the airplane is a matter of consciously fixing the relationship of a specific reference point on the airplane to the horizon. As basic flight skills are developed through experience and training, the pilot will acquire a continuous awareness of these relationships without conscious effort. The reference points will be used almost subconsciously in varying degrees to determine the attitude of the airplane during all maneuvers.

In establishing the reference points, the airplane should be placed approximately in the desired attitude, and then a specific point should be selected. No two pilots see this relationship exactly the same. The apparent position of reference points will depend on each pilot's seat height and lateral position, and/or the pilot's eye level and line of sight. It is imperative that the student utilize the same seat position on each flight so that the reference points remain the same.

302. INTEGRATED FLIGHT INSTRUCTION

In introducing the basic flight maneuvers, the "integrated flight instruction" method will be used. This means that each flight maneuver will be performed by using both outside visual references and the flight instruments.

When pilots use this method, they achieve a more precise and competent overall piloting ability. It results in less difficulty in holding desired altitudes, controlling airspeed during takeoffs, climbs, descents, and landing approaches, and in maintaining headings in the traffic pattern, as well as on cross-country flights.

The use of integrated flight instruction does not, and is not intended to, prepare pilots for flight in instrument weather conditions. It does, however, provide an excellent foundation for flight during the Instrument Navigation stage of training, and will result in the pilot becoming a more accurate, competent, and safe pilot.

A sharp lookout for other aircraft must be maintained at all times, particularly when using instrument references, to avoid the possibility of a collision. Frequently, other aircraft are unnoticed until they suddenly appear within the limited area of the pilot's vision. Consequently, it is imperative that the pilot not only divide attention between controlling the airplane by outside visual references and flight instruments, but also be observant of other aircraft. For visual flight, the pilot's scan should be directed outside the cockpit at least 80 - 90% of the time!

303. ATTITUDE FLYING

Airplane control is composed of four components:

1. **Pitch control:** Pitch control is the control of the airplane (longitudinal axis) about its lateral axis by applying elevator pressure to raise or lower the nose, usually in relation to the horizon.
2. **Bank control:** Bank control is the control of the airplane (lateral axis) about its longitudinal axis by use of the ailerons to attain the desired angle of bank in relation to the horizon.
3. **Yaw control:** Yaw control is the control of the aircraft (longitudinal axis) about its vertical axis by use of the rudder.
4. **Power control:** Power control is the control of power or thrust by use of the PCL to establish or maintain desired airspeeds in coordination with the attitude changes.

The Primary Flight Display (PFD) displays both the pitch and bank attitude of the aircraft and shows the aircraft's direction of flight.

- The attitude indicator shows directly both the pitch and bank attitude of the airplane.
- The heading indicator shows directly the airplane's direction of flight.
- The altimeter indicates the airplane's altitude and, indirectly, the need for a pitch change.
- The vertical speed indicator shows the rate of climb or descent.

3-2 FUNDAMENTAL FLIGHT CONCEPTS

- The airspeed indicator shows the results of power and/or pitch changes in the airplane's speed.

The outside visual references used in controlling the airplane include the airplane's nose and wingtips to show both the airplane's pitch attitude and flight direction, with the wings and frame of the windscreen showing the angle of bank.

304. "SEE AND AVOID" DOCTRINE

Simply stated, the "See and Avoid" Doctrine is a pilot's best defense against a midair collision. The "Big Sky, Little Airplane" theory is the key ingredient in the recipe for a midair collision. The causal factor most often noted in aircraft accident reports involving midair collisions is, "failure of the pilot to see and avoid the other aircraft." In most cases, at least one of the pilots involved could have seen the other in time to avoid contact if he had been using his eyes properly.

Studies show that nearly all midair collisions occur during daylight hours, in VMC weather. Most midairs occur within five miles of an airport, in the areas of greatest traffic concentration, and usually on warm, weekend days. Most midairs also involve maneuvers that are classified as crossing or overtaking. Very rarely are head-on collisions reported.

It is also noteworthy to find that the closing speed (rate at which two aircraft approach each other) in a crossing or overtaking maneuver is often relatively slow, usually much slower than the airspeed of either aircraft involved. Again, that is because the majority of midair collisions are the result of a faster aircraft overtaking and striking a slower one.

Studies also reveal some interesting information regarding the vulnerabilities of the human eye and how its limitations contribute to midair collisions.

The eye, and consequently vision, is vulnerable to just about everything: dust, fatigue, emotion, germs, fallen eyelashes, age, optical illusions and alcoholic content. In flight, our vision is affected by atmospheric conditions, windscreen distortion, too much or too little oxygen, acceleration, glare, heat, lighting and aircraft design. Most importantly, the eye is vulnerable to the vagaries of the mind. We "see" and identify only what the mind lets us see. For example, a daydreaming pilot staring into space sees no approaching traffic and is a candidate for a midair collision.

A constant problem source to the pilot (though he is probably never aware of it) is the time required for "accommodation." Our eyes automatically accommodate for (or focus on) near and far objects. But the change from something up close, like a dark panel two feet away, to a well-lit landmark or an aircraft target a mile or so away, takes one to two seconds or longer for eye accommodation. That can be a long time when you consider that you need 10 seconds to avoid a midair collision.

Another focusing problem occurs on drab, colorless days above a haze or cloud layer when no distinct horizon is visible. If there is little or nothing to focus on, we do not focus at all. We

experience something known as "empty-field myopia;" we stare but see nothing, not even opposing traffic.

The effects of "binocular vision" have been studied by the National Transportation Safety Board (NTSB) during investigations of midair collisions. The board concluded that this is also a causal factor. To actually accept what we see, we need to receive cues from both eyes. If an object is visible to one eye, but hidden from the other by a windscreen post or other obstruction, the total image is blurred and not always accepted by the mind.

Another inherent eye problem is that of narrow field of vision. Although our eyes accept light rays from an arc of nearly 200°, they are limited to a relatively narrow area (approximately 10-15°) in which they can actually focus on and classify an object. Though we can perceive movement in the periphery, we cannot identify what is there. We tend not to believe what we see out of the corner of our eyes. This often leads to "tunnel vision."

That limitation is compounded by the fact that at a distance, an aircraft on a collision course will appear to be motionless. It will remain in a seemingly stationary position, without appearing either to move or to grow in size for a relatively long time, and then suddenly bloom into a huge mass filling the canopy. This is known as "blossom effect." We need motion or contrast to attract our eyes' attention. A large bug smear or dirty spot on the windscreen can hide a converging plane until it is too close to be avoided.

In addition to built-in problems, the eye is also severely limited by environment. Optical properties of the atmosphere alter the appearance of traffic, particularly on hazy days. "Limited visibility" actually means "limited vision." You may be legally Visual Flight Rules (VFR) when you have three miles visibility, but at that distance, on a hazy day, opposing traffic is not easy to detect. At a range closer than three miles, even though detectable, opposing traffic may not be avoidable.

Lighting also affects our vision. Glare, usually worse on a sunny day over a cloud deck or during flight directly into the sun, makes objects hard to see and scanning uncomfortable. Also, a well-lighted object will have a high degree of contrast and be easy to detect, while one with low contrast at the same distance may be impossible to see. For instance, when the sun is behind you, an opposing aircraft will stand out clearly, but when you are looking into the sun, and your traffic is "back-lighted," it is much more difficult to see.

A contrast problem exists when trying to see an airplane against a cluttered background. If an aircraft is between you and terrain that is varied in color or heavily dotted with buildings, it will blend into the background until it becomes quite close.

So what can we do to overcome the vulnerabilities of the eye? The most important thing is to develop a scan that is both comfortable and workable for your own airplane. In normal flight, the threat of a midair collision is greatly diminished by scanning an area 60° either side of center and 10° up and down. Refer to Figure 3-1. This does not mean that the rest of the area should be ignored.

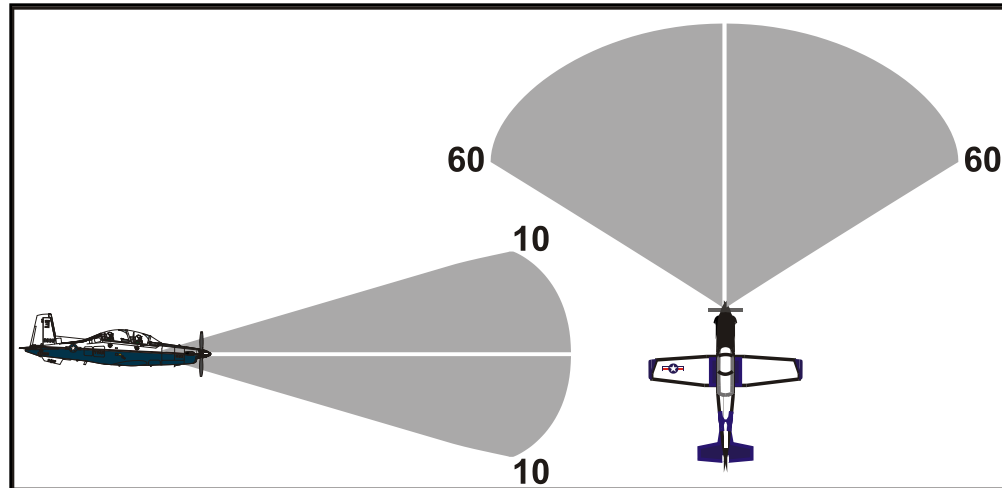

Figure 3-1 Outside Scan

Traffic Collision Avoidance System (TCAS) can enhance a pilot's visual scan by detecting several aircraft simultaneously. Depending upon the mode selected, a series of traffic advisory symbols (see T-6B NATOPS Flight Manual) may appear, enabling earlier visual detection of possible conflicting traffic. In this way the TCAS effectively complements but does not replace the VFR scan, which remains the pilot's primary means to see and avoid conflicting traffic.

Many times the threat of an impending midair collision is evident early enough for the aircrew to discuss the threat and coordinate a decision regarding deviation from the flight path to avoid it. However, this will not always be the case. The other aircraft may be sighted at a point which will prevent discussion with, or even notification of, the other crewmember. This would require immediate action! In such a situation, students are expected to take the controls and/or initiate a deviation in either bank, pitch or power (or combination of these) to displace the aircraft from its current flight path in order to avoid the collision. This concept holds true even if the deviation involves either high positive or negative "G" loads. Avoiding the collision takes priority over preventing an overstress! This situation should be addressed during the preflight briefing. If a TCAS advisory is encountered outside the landing pattern, cease dynamic maneuvering and attempt to gain visual contact with traffic. Do not make a traffic avoidance maneuver solely based on TCAS until you have acquired the traffic visually.

305. FLIGHT INSTRUMENTS

Of the basic skills required for flight, instrument interpretation requires the most thorough study and analysis. It begins with your understanding of each instrument's construction and operating principles. Then you must apply this knowledge to the performance of the aircraft you are flying, the particular maneuvers to be executed, the scan and control methods, and the flight conditions in which you are operating. For each maneuver, you will learn what performance to expect and the combination of items that you must interpret in order to control aircraft attitude during the maneuver.

For flight that is not restricted to cockpit references for setting aircraft attitudes, the following flight instruments (located on the PFD) will comprise the group to be used as "crosscheck" or performance instruments in succeeding chapters:

- Attitude Indicator
- Altimeter
- Vertical Speed Indicator (VSI)
- Airspeed Indicator
- Heading Indicator
- Turn and Bank Indicator (Turn needle and ball)

NOTE

For a complete discussion of these instruments, refer to the T-6B NATOPS Flight Manual Chapter I.

306. SCAN PATTERN

The tool that all pilots must employ to guard against midair collisions is an efficient scan pattern. Division of attention, or scanning, is the "awareness" that a pilot must possess in order to fly his/her aircraft effectively. It is quite obvious that you must:

- Look outside the airplane to see where you are going.
- Look at the aircraft with respect to the horizon to check and maintain a desired attitude.
- Look inside the aircraft to check for proper power settings, flight instrument readings and any signs of malfunctions.

Combined with the diversified attention involved in the fundamental control of the aircraft is the concern that must be devoted to flight safety: avoiding other aircraft. Behind the proper division-of-attention methods, which you learn in training, lies the foundation for the mandatory alertness of the military pilot.

It might seem that the task of having to be aware of so many events and circumstances at the same time is impossible. However, the ability to do so is an integral part of your flight training and can be developed naturally. Of course, as in any endeavor, its development is expedited by a conscientious effort to learn.

In order to divide your attention, your development of an efficient scan pattern will offer the most efficient means by which you can readily ascertain required information and not dwell on any one item with subsequent failure to notice other equally important details.

A scan pattern is a means, or procedure, by which you can observe everything you need to see by starting at one point, moving visually about the aircraft, checking all applicable items systematically and thoroughly, and completing the pattern at the starting point. A scan pattern may be started anywhere, but it must be complete and continuous.

What we refer to as the integrated scan involves combining contact flying and flight instruments through a systematic pattern. The task of scanning in contact flying (VMC) involves division of attention between the external and internal environment, setting attitudes with the nose and wings in relation to the horizon, and cross-checking them against the instruments in the cockpit. The following scan pattern is a workable example:

1. **Outside the cockpit:**

- a. Attitude and area - Nose in proper relation to horizon and geographical references for heading and position.
- b. Area - Airspace between nose and left wing clear of hazards.
- c. Attitude - Left wing in proper relation to horizon.

2. **Inside the cockpit:**

- a. Attitude - Check wings level with PFD and correct nose position with the altimeter and VSI.
- b. Performance - Check airspeed indicator and power setting.

3. **Outside the cockpit:**

- a. Attitude and area - Nose in proper relation to horizon and geographical references for heading and position.
- b. Area - Airspace between nose and right wing clear of hazards.
- c. Attitude - Right wing in proper relation to horizon.

As a beginner, you may crosscheck rapidly by "looking" without knowing exactly what you are looking for, but with increasing familiarity with the maneuvers and experience with the support instruments, you will learn:

What to look for,

When to look for it, and

What response is required.

As proficiency increases, you will scan primarily from habit by adjusting your scanning rate and sequence to the demands of the situation. The scan requirements will vary from maneuver to

maneuver, so initially the scanning process will seem new and somewhat unnatural. It cannot be overemphasized, however, that your level of success in flight training will vary proportionately with your ability to force yourself to develop and maintain a correct and expeditious scan pattern.

The entire pattern should take very little time and no one item should fix your attention at the exclusion of another. Meanwhile, corrections should be initiated for any errors detected and the next scan over the pattern will enable you to further correct or perfect your condition of flight.

There are other methods of scanning, some of which may be more effective for you than the preceding type. Figures 3-2 and 3-3 illustrate other frequently utilized outside scan patterns.



Figure 3-2 Side-to-Side Scanning Method

Start at the far left of your visual area and make a methodical sweep to the right, pausing in each block of viewing area to focus your eyes. At the end of the scan, return to the panel.



Figure 3-3 Front-to-Side Scanning Method

An equally effective scan pattern is the front-to-side method illustrated in Figure 3-3. In this pattern, start in the center block of your visual field (center of front windscreen), move to left focusing in each block, then, after reaching the last block on the left, swing quickly back to the center block and repeat the performance to the right. At the end of the scan, return to the panel. There are no real advantages or disadvantages of one method over the other. Use the method that works best for you.

In order to establish an efficient and useful scan in flight, one also has to establish a good internal (instrument) scan and learn to give each instrument its proper share of time. The amount of time spent scanning outside the cockpit in relationship to inside depends on cockpit workload and traffic density.

Remember, while you are looking at the instruments, the nose attitude and wing position may become erratic, and while you look at the nose position and correct it, the instrument readings may vary. You cannot afford to gaze at any one item for any length of time or the pattern will be broken (this is referred to as "fixating"). Instead, scan each position, initiate corrections, and then check those corrections when you return to that position in the scan pattern. Be alert! Look around! Remember that under you is a blind spot. Never assume that others see you!

307. BALANCED FLIGHT

Balanced flight exists when the aircraft is neither in a slip nor a skid as it progresses along a flight path. With respect to balanced flight, there are two principles of control application:

- Any control deflection will result in an attitude change until the control is returned to neutral.
- There is a definite aerodynamic interrelationship between the rudder and aileron to maintain balanced flight.

For an aircraft to be in a balanced flight condition, the controls must be applied so that the longitudinal axis lies in the plane of forward motion. The utilization of either the rudder or the ailerons, independent of one another, will result in a condition of unbalanced flight. The "turn and bank" indicator indicates an unbalanced condition by moving away from the center position in the direction of the slip or skid. The pilot can also recognize this condition by an awareness of a sensation of side motion. The side motion causes a tendency to lean in the direction of the slip or skid. This unbalanced condition can be corrected by the proper application of the rudder, ailerons, or both.

308. TURNS

The turn is the most complex of all the basic flight maneuvers. During the turn, coordinated use of all three flight controls is required. Although there are other important considerations, the first requirement for the turn is that balanced flight be maintained.

You will recall that when an airplane is flying straight and level, the total lift is acting perpendicular to the wings and to the earth. As the airplane is banked into a turn, the lift then becomes the resultant of two components. One, the vertical component, continues to act perpendicular to the earth and opposes gravity. The other, the horizontal component, acts parallel to the earth's surface and opposes centrifugal force caused by the turn. These two lift components act at right angles to each other, causing the resultant lifting force to act perpendicular to the banked wings of the airplane. It is this lifting force that actually turns the airplane, not the rudder.

When applying aileron to bank the airplane, the depressed or lowered aileron (on the rising wing) produces a greater drag than the raised aileron (on the lowering wing). This increased aileron drag, which is called adverse yaw, tends to yaw the airplane towards the rising wing, or opposite to the desired direction of turn, while the banking action is taking effect. To counteract the yawing tendency, rudder pressure must be applied simultaneously in the desired direction of turn. This produces a coordinated turn.

After the bank has been established in a theoretically perfect turn in smooth air, all pressure on the aileron control may be relaxed. The airplane will remain at the bank selected with no further tendency to yaw since there is no longer a deflection of the ailerons. As a result, pressure may also be relaxed on the rudder pedals, and the rudder allowed to streamline itself with the direction of the air passing it. If pressure is maintained on the rudder after the turn is established, the airplane will tend to skid to the outside of the turn. If a definite effort is made to center the rudder rather than let it streamline itself to the turn, it is probable that some opposite rudder pressure will be exerted inadvertently. This would tend to force the airplane to yaw opposite its original turning path. As a result, the airplane would tend to slip to the inside of the turn. The

ball in the turn indicator will be displaced off-center whenever the airplane is skidding or slipping (Figure 3-4).

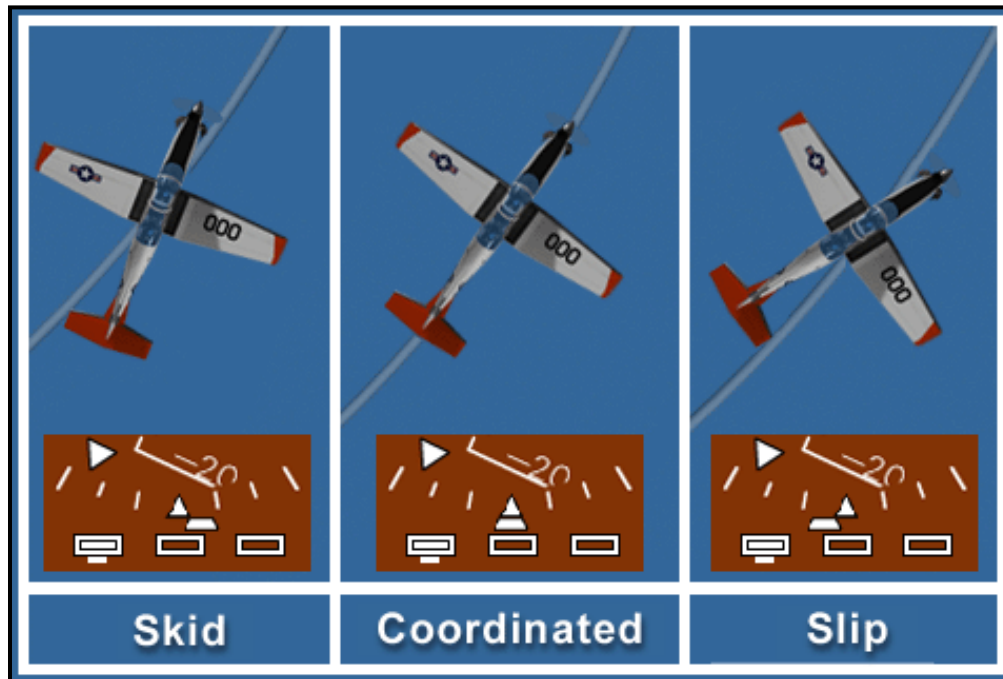

Figure 3-4 Coordinated vs. Uncoordinated Turns

In all turns in which a constant altitude is to be maintained, it is necessary to increase the angle of attack by applying back elevator pressure. This is required because the lift produced to equal the weight of the airplane and the centrifugal force caused by the turn must be obtained from the wing to maintain altitude. The force of lift must be further increased as the turn becomes steeper and the centrifugal force builds up, but must be slowly decreased as the airplane is being rolled back to level flight when completing the turn.

To stop the turn, the wings must be returned to laterally level flight by the use of the ailerons, and the resulting adverse yaw (now acting in the same direction as the turn), must be overcome by the coordinated application of rudder. The yaw effect will often be more apparent when rolling out of a turn than rolling into a turn, due to the higher angle of attack and wing loading which exists when the rollout is started.

To understand the relationship between airspeed, bank, and radius of turn, it must be recalled that the rate of turn at any given airspeed depends on the amount of sideward force causing the turn; that is, the horizontal component. The horizontal lift component varies in proportion to the amount of bank. Thus, the rate of turn at a given airspeed increases as the angle of bank is increased. On the other hand, when a turn is made at a higher airspeed for a given bank angle, the centrifugal force created by the turn becomes greater, causing the turning rate to become slower with an increase in radius of turn. It can be seen, then, that at a given angle of bank, a higher airspeed will make the radius of the turn larger because the airplane will be turning at a slower rate.

The inherent positive stability of the T-6B wing has an effect on the manner in which it turns. Turns in the T-6B may be divided into three types: shallow, moderate, and steep. Briefly, if a shallow angle of bank turn is established and the controls released, the aircraft tends to return to level flight. This may not always occur, because friction in the control surface rigging may cause a very slight control deflection. In a moderately banked turn, if the aileron and rudder pressures are released, the aircraft will tend to stay at the established angle of bank. In a steep angle of bank turn, the aircraft will tend to increase its bank. The actual amount of angle of bank for each type is undefined and varies with changes in airspeed and configuration.

The pilot's posture while seated in the airplane is very important in all maneuvers, particularly during turns as it affects the alignment of outside visual references. At the beginning, the student may lean to the side when rolling into the turn in an attempt to remain upright in relation to the ground rather than "ride" with the airplane. This tendency must be corrected at the outset if the student is to learn to properly use visual references.

As in all maneuvering, the pilot should form the habit of ensuring that the area towards which a turn is to be made is clear of other aircraft. If nearby aircraft are not detected before lowering the wing, it may be too late to avoid a collision.

As soon as the airplane rolls from the wings-level attitude, the nose should also start to move along the horizon, increasing its rate of travel proportionately as the bank is increased. Any variation from this will be indicative of the particular control that is being misused. The following variations provide excellent guides:

- If the nose starts to move before the bank starts, rudder is being applied too soon.
- If the bank starts before the nose starts turning, or the nose moves in the opposite direction, the rudder is being used too late.
- If the nose moves up or down when entering a bank, excessive or insufficient back elevator pressure is being applied.

During all turns, the ailerons and rudder are used to correct minor variations just as they are in straight-and-level flight. However, during very steep turns, considerably more back elevator pressure and trim is required to maintain altitude than in shallow and moderate turns, and additional power may be needed to maintain a safe airspeed. Frequently, there is a tendency for the airplane's nose to lower, resulting in a loss of altitude.

To recover from an unintentional nose-low attitude during a steep turn, the pilot should first reduce the angle of bank with coordinated aileron and rudder pressure. Then back elevator pressure should be used to raise the airplane's nose to the desired pitch attitude. After accomplishing this, the desired angle of bank can be reestablished. Attempting to raise the nose first by increasing back elevator pressure will usually cause a tight descending spiral, and could lead to overstressing the airplane or stall.

309. THE ONE-THIRD RULE

Since the airplane will continue turning as long as there is any bank, the rollout must be started before reaching the desired heading. The amount required to lead the heading will depend on the rate of turn and the rate at which the rollout will be made; however, a good rule of thumb is to start the rollout one-third the number of degrees of angle of bank in use. Example: If a 30° angle of bank turn was being used, the rollout would be started 10° prior to the desired heading. As the wings become level, the control pressures should be gradually and smoothly released so that the controls are neutralized as the airplane assumes straight-and-level flight. As the rollout is being completed, attention should be given to outside visual references as well as the PFD to determine that the wings are being leveled precisely and the turn stopped.

310. SKID

A skid occurs when the aircraft slides sideways away from the center of a turn. It is caused by too much rudder pressure in relation to the angle of bank used. In other words, if you try to force the aircraft to turn faster without increasing its degree of bank, the aircraft will skid sideways away from its radius of turn. In a turn, the rudder must follow the flight path of the aircraft. If excessive pressure is maintained on the rudder after the turn is established, a skid will result. Figure 3-5 shows a coordinated turn and a skid.

A skid may also occur when you are flying in a level flight attitude if the nose of the aircraft is permitted to move sideways along the horizon when the wings are level. This condition would occur when excessive rudder pressures are applied or when the aircraft is improperly trimmed. A skidded turn can develop into a dangerous situation when in close proximity to the ground. Essentially, what occurs is the wing on the inside of a turn is moving slower than the outside wing. Since the slower wing develops less lift during a skid, this compounds the reduction in lift, eventually developing into a stall of one wing. The result: unintentional inverted flight!

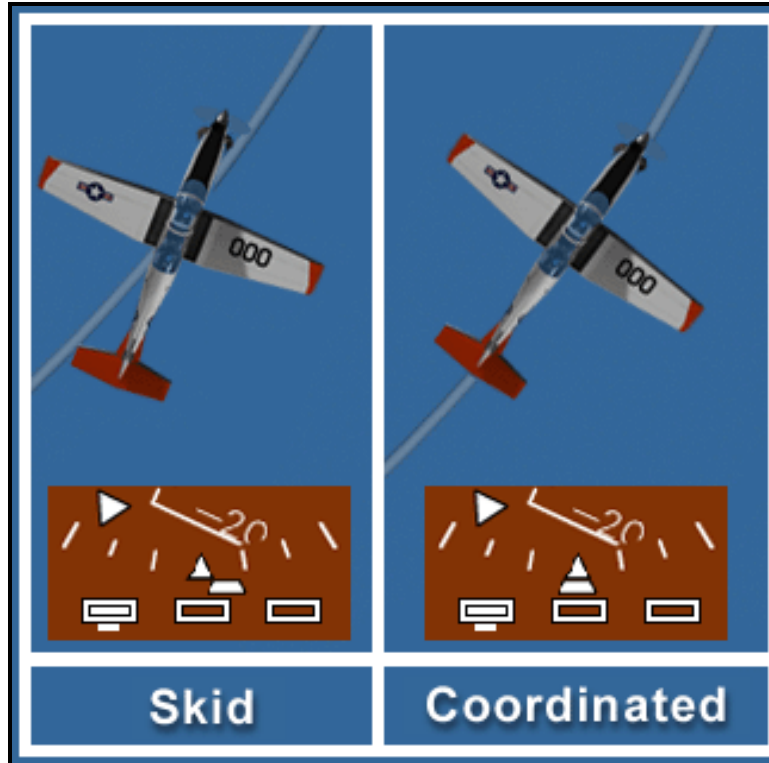

Figure 3-5 Skidded vs. Coordinated Turn

311. SLIP

A slip occurs when the aircraft slides sideways towards the center of the turn. It is caused by an insufficient amount of rudder in relation to the amount of aileron and the angle of bank used. If you roll into a turn without using coordinated rudder and aileron, or if you hold rudder against the turn after it has been established, the aircraft will slide sideways towards its center of turn. A slip may also occur in straight and level flight if one wing is allowed to drag; that is, flying with one wing low, while holding the nose of the aircraft straight by the use of the rudder pressure. In this case, the aircraft slips downward towards the earth's surface and loses altitude. An intentional slip is not a dangerous maneuver. The slip is an acceptable method to safely dissipate excess altitude under certain conditions discussed later in this manual. Any inadvertent tendency to fly in out-of-balanced flight (either a slip or skid) is **NOT** an acceptable practice.

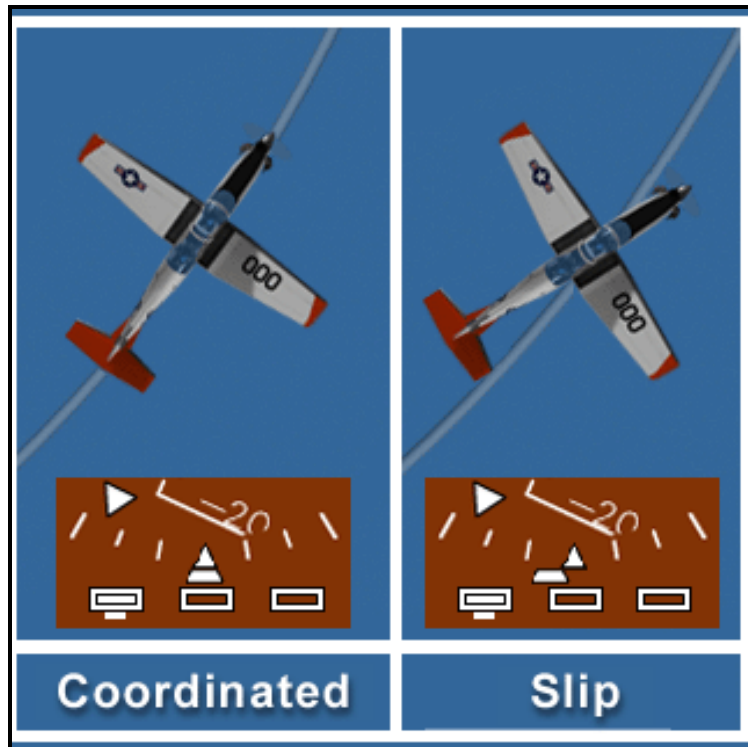

Figure 3-6 Coordinated vs. Slip Turn

The flight paths for a coordinated turn and a slipping turn are depicted in Figure 3-6. During a turn, balanced flight is maintained by causing the aircraft to move in a curve at a rate which is in direct proportion to the degree of bank. The angle of bank is established by the coordinated application of ailerons and rudder. The amount of rudder required to establish a turn is dependent upon the rate at which the angle of bank is established. In other words, rolling into a turn rapidly requires more rudder than rolling into the same turn slowly. This interrelationship is absolute and should be thoroughly understood.

The overlapping function of the controls provides a safety factor in the control of the aircraft. It is quite possible to fly the plane without the use of one or more controls. For example, suppose that the elevators failed to operate properly. It is possible to control the position of the nose by the use of power. As the power is increased, the nose will rise; as the power is decreased, the nose will drop.

It is also possible to bank the airplane and to turn it without the use of the ailerons. Using only the rudder, the plane can be turned in any desired direction. This use of the rudder will cause the aircraft to yaw or skid in the direction in which the rudder is applied. During the yawing motion, the outside wing moves faster through the air than the inside wing. This increases the lift of the outside wing, causing it to rise, thus producing a bank in the direction in which the rudder is applied. A turn can also be accomplished by using only the ailerons. In this instance, the aircraft will have a tendency to slip before it begins to turn.

The foregoing discussion was given to show the advantage of the overlapping functions of the controls. It must be emphasized, however, that smooth and balanced flight can only be achieved through the proper coordination of all controls. You can also make it easy on yourself by trimming the aircraft.

312. WIND EFFECTS AND CRAB CORRECTIONS

Inasmuch as an aircraft flies in an air mass, any movement of this air mass affects the course of the aircraft. In other words, the path of the aircraft over the ground will be determined not only by the direction in which it is headed, but also by the direction and velocity of the air mass movement. In perfectly still air, for example, the nose of the aircraft points exactly in the same direction as its path over the ground or, to put it another way, the path of the aircraft through the air and its path over the ground coincide. However, you will notice the aircraft does not always follow a course over the ground in the same direction the nose is pointed.

You have been or will be, at one time or another, flying parallel to a road or section line. The longitudinal axis of the aircraft is aligned perfectly with this road or section line and you are flying a straight and level course. Suddenly, you realize that the aircraft is getting closer to the road or has actually crossed it, without any turn having been made. This would indicate to you that the air in which you are flying is moving in a direction which has caused the aircraft to cross the road at some angle.

Suppose you were flying along straight and level and the wind was blowing 30 knots from a direction 90° to your left. At the end of one hour, the body of air in which you were flying would have moved 30 miles to your right. Since the aircraft was in the body of air, and moving with it, you and the aircraft would also have drifted 30 miles to your right in one hour. Of course, in relation to the air mass itself, you would have moved forward only, but in relation to the ground, you would have moved forward and 30 miles sideways. This effect of the movement of the air on the track of the aircraft is known as drift. The difference between the actual heading of the aircraft and its track over the ground is called the angle of drift. Drift must be compensated for, in order to cause the aircraft to maintain a desired track over the ground. The proper way to correct the drift when you are flying in straight and level flight and wish to follow a desired ground track, is to make a shallow balanced turn into the wind. When you seem to have the drifting effect neutralized or stopped, return to straight and level flight. The aircraft is now pointed into the wind slightly. This causes the aircraft to fly into the wind at the rate that the wind is trying to move it sideways. Since the effect of drift has now been neutralized, the aircraft will fly a straight and selected ground track. The nose of the aircraft, however, is not pointed in the direction of the ground track. This is known as drift correction, and is usually referred to as "crabbing" because the aircraft is moving sideways in relation to the ground (Figure 3-7).

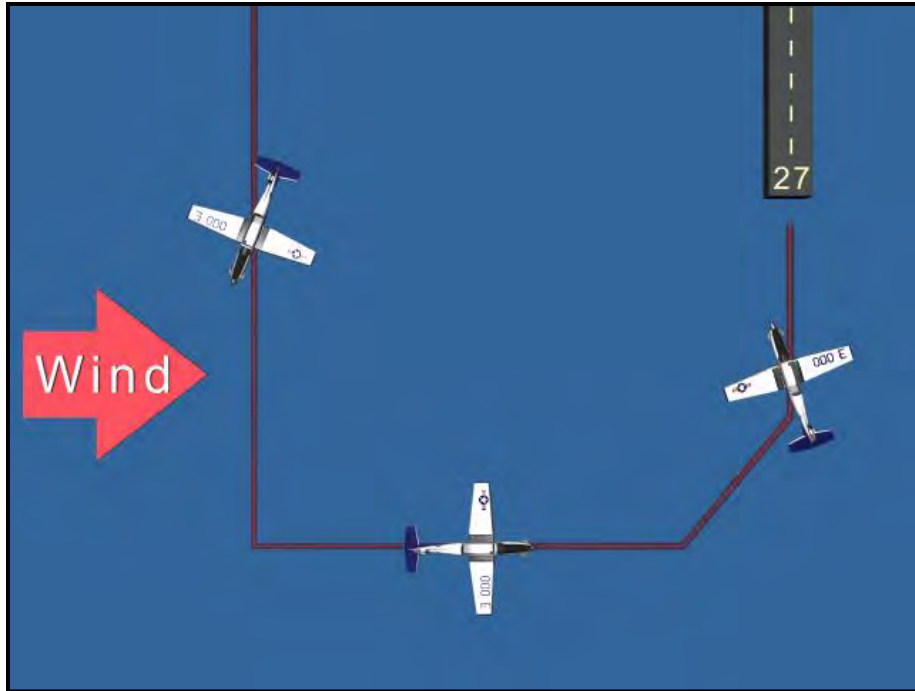

Figure 3-7 "Crabbing" Flight Path

313. CLIMBING FLIGHT

For an automobile to go uphill at the same speed as that being maintained on a level road, the driver must "step on the gas"; that is, power must be increased. This is because it takes more work to pull the car's weight up the hill and to maintain the same speed at which the car was moving along the level road. If the driver did not increase the power, the automobile might still climb up the incline, but it would gradually slow down to a speed slower than that at which it was moving on the level road.

Similarly, an airplane can climb at the cruise power setting with a sacrifice of speed, or it can, within certain limits, climb with added power and no sacrifice in speed. Thus, there is a definite relationship between power, attitude, and airspeed.

When transitioning from level flight to a climb, the forces acting on the airplane go through definite changes. After the addition of power, an increase in lift occurs when back pressure is applied to the elevator control. This initial change is a result of the increase in the angle of attack, which occurs when the airplane's pitch attitude is being raised. This results in a climbing attitude. When the inclined flight path and the climb speed are established, the angle of attack and the corresponding lift again stabilize.

As the airspeed decreases to the climb speed, the downward force of the air striking the horizontal stabilizer becomes less, creating a longitudinally unbalanced condition that produces a tendency for the airplane to nose down. To overcome this tendency and maintain a constant climb attitude, additional back pressure must be applied to the elevator control.

The primary factor which affects an airplane's ability to climb is the amount of excess power available; that is, the power available above that which is required for straight-and-level flight.

During the climb, lift will increase with the flight path, so that it is not directly opposing gravity to support the airplane's weight. With the flight path inclined, the lift is partially acting rearward.

This adverse or retarding lift is termed induced drag. This adds to the total drag. Since weight is always acting perpendicular to the earth's surface and drag is acting in a direction opposite to the airplane's flight path during a climb, it is necessary for thrust to offset both drag and gravity.

As the aircraft continues to climb at a constant angle of attack, torque will drop off as air density decreases. The volume of air entering the induction system gradually decreases, resulting in a pressure reduction within the combustion chamber. Consequently, power decreases. The PCL must be continually advanced to maintain constant power.

314. CLIMBING TURNS

In developing skills to perform climbing turns, the following factors should be considered:

- With a constant power setting, the same pitch attitude and airspeed cannot be maintained in a bank as in a straight climb, due to the decrease in effective lift during a turn.
- The degree of bank should be neither too steep nor too shallow. Too steep a bank intensifies the effect mentioned above. If too shallow, the angle of bank may be difficult to maintain because of the inherent stability of the airplane.
- A constant airspeed, a constant rate of turn, and a constant angle of bank must be stressed. The coordination of all controls is likewise a primary factor to be stressed and developed.
- The airplane will have a greater tendency towards nose-heaviness than in normal straight climb, due to the decrease in effective lift that is the case in all turns.
- As in all maneuvers, attention should be diverted from the airplane's nose and divided among all references equally.

All of the factors that affect the airplane during level (constant altitude) turns will affect it during climbing turns or any other turning maneuver. It will be noted that because of the low airspeed, aileron drag (adverse yaw) will have a more prominent effect than it did in straight-and-level flight and more rudder pressure will have to be blended with aileron pressure to keep the airplane in coordinated flight during changes in bank angle. Additional elevator deflection and trim will also have to be used to compensate for centrifugal force and loss of vertical lift, and to keep the pitch attitude constant.

During climbing turns, the loss of vertical lift becomes greater as the angle of bank is increased, so shallow turns must be used to maintain a sufficient rate of climb. If a medium or steep banked

turn is used, the airplane will not climb sufficiently.

315. DESCENDING FLIGHT

When the power is reduced during straight and level flight, the thrust needed to balance the airplane's drag is no longer adequate. Due to the unbalanced condition, the drag causes a momentary reduction in airspeed. This decrease in speed, in turn, results in a corresponding decrease in the wing's lift. The weight of the airplane now exceeds the force of lift so the resulting flight path is downward, with the force of gravity providing a portion of the forward thrust. In effect, the airplane is actually going "downhill."

As in entering a climb, the forces acting on an airplane again go through definite changes when transitioning from level cruising flight to a descent. When forward pressure is applied to the elevator control or the airplane's pitch attitude is allowed to lower, the wing's angle of attack is decreased, the lift is reduced, and the flight path starts downward. The initial reduction of the lift, which starts the airplane downward, is momentary. When the flight path stabilizes, the angle of attack and lift stabilize.

316. THE P.A.T. PRINCIPLE

For corrections and to execute many maneuvers you must:

- Set/reset power
- Adjust the nose attitude
- Trim for the new attitude

The mechanics of the transitions will be performed in a specific sequence:

- *Power*
- *Attitude*
- *Trim*

Although power and attitude change are almost simultaneous, lead with PCL movement. For example, consider the transition to an enroute descent. Reduce power from normal cruise to the descent power setting, scanning the nose attitude. As the power is retarded, lower the nose towards a descending attitude. Finally, trim the aircraft.

NOTE

The power may not be exactly the descent power setting, since it was initially reduced using peripheral vision. Power is then reset to exactly the descent power setting after completing P.A.T. Remember - Power, Attitude, Trim; reset Power, reset Attitude, reset Trim.

317. ASSUMING CONTROL OF THE AIRCRAFT

A most important flying safety requirement is a clear, positive understanding at all times of who has control of the aircraft. You must understand the procedures involved in transferring control of an aircraft.

The instructor will tell you over the intercommunications system (ICS), "I have the controls." When your instructor says, "I have the controls," you acknowledge by stating over the ICS, "You have the controls." You then take your hands and feet off the controls. Your instructor will then confirm control by saying, "I have the controls." Conversely, but in the same manner, when your instructor wants you to fly, he/she will say, "You have the controls," whereupon you will take control and acknowledge over the ICS, "I have the controls." The instructor will then complete the exchange with another, "You have the controls." Keep flying the aircraft until you are told to do otherwise. Understand that unless you and the instructor complete the 3-way exchange of controls, no exchange of control was made. For example, your instructor may coach or aid your flare during a landing. You may feel a presence on the control stick, but you are still flying and should continue to do so. Never be in doubt as to who is flying; if you are not absolutely sure, safety dictates you *speak up and ask!*

CHAPTER FOUR GROUND PROCEDURES

400. INTRODUCTION

This chapter discusses the basic procedures essential to the safe operation of the airplane on the ground prior to and after a flight. This includes the major points of ensuring that the airplane is in an airworthy condition, starting and stopping the engine and taxiing the airplane to and from the line area and the runway.



Figure 4-1 T-6B Taxiing

In the line area, there is usually considerable activity - aircraft may be operating at high power settings, taxiing in and out of the area, taking off and landing on nearby runways; fuel trucks and people may be moving about the aircraft. Therefore, constant vigilance must be exercised while performing ground operations.

The propeller is the most dangerous part of the airplane, since under certain light conditions it is difficult to see a revolving propeller. This may give the illusion that it is not there. As a result, the files of Aviation Safety Offices contain many cases that read, "Victim walked into a rotating propeller."

While approaching the airplane, the pilot should note the presence of obstructions and articles such as fire extinguishers, fueling or maintenance equipment, or chocks that could be a hazard when taxiing the airplane.

401. NAVAL AVIATION LOGISTICS COMMAND MAINTENANCE INFORMATION SYSTEM

The Naval Aviation Logistics Command Maintenance Information System (NALCOMIS) is the standard fleet-wide maintenance system for aviation and used for T-6B maintenance. It is a fully integrated, computerized system allowing input, tracking, and monitoring in real time. This data is integrated for the pilot in the Aircraft Discrepancy Book (ADB), which is a designated maintenance binder for each T-6B aircraft on the line and is available at aircraft issue. The ADB is primarily used for pre-flight operations by aircrew to check the aircraft's maintenance status and maintenance actions over its last ten flights. Aircrews use an electronic Maintenance Action Form (MAF) to document aircraft discrepancies. The electronic MAF is used to ensure an accurate record is kept of all maintenance performed on an aircraft. Your instructor will show you how to access this information.

All discrepancies are assigned either an UP or DOWN status. A discrepancy assigned an UP status does not impair the safety-of-flight or mission capability of the aircraft. An airplane may be flown with outstanding (not yet corrected) UP write-ups or gripes, with no danger to the crew. An example of an UP gripe would be "paint peeling off leading edge of starboard wing just forward of the pitot tube." Notice the specific details used in this example. Detailed discrepancy reports foster a closer working relationship between aircrew and maintenance and save both time and money.

A discrepancy assigned a DOWN status immediately "downs" the aircraft until it is fixed. You must be able to interpret an outstanding MAF and determine whether the aircraft is safe for flight. Besides any uncorrected write-ups, discrepancies recorded over the past ten flights should be reviewed as a minimum.

402. CHECKLISTS

It is mandatory to use checklists to inspect, start, and ensure aircraft systems are operating properly. There is no excuse for lack of checklist discipline. Checklists ensure the standardization of all operating procedures pertaining to the aircraft and provide a logical, safe, and precise sequence to follow.

The accomplishment of a safe, productive flight begins with a thorough T-6B Exterior Inspection Preflight Check before the crew enters the aircraft. The varied ground checklists ensure the aircraft is properly prepared and ready for flight. Always with safety in mind, remain vigilant and disciplined when executing the ground checklists. The majority of your initial checklist training will take place in the simulators prior to your first flight. By your first Contact flight, you are expected to conduct all the checklists as per the T-6B NATOPS Flight Manual and In-flight Guide (and/or wing checklist guide equivalent).

The checklists will be conducted in the challenge-action-response format. This means you report the challenge, accomplish the required action, and state the appropriate response. As you check each item, place your hand on the item to ensure the desired position is selected. Most checklists are not performed from memory; however, the following checklists performed during

critical phases of flight should be performed from memory. (Lineup Check, After Takeoff, Ops Check, Before Landing) All checklists must flow efficiently and precisely.

403. BASIC 1001

1. **Description.** N/A
2. **General.** Prior to your first flight, there are several fundamental topics that you, as a student aviator, must be aware of and understand if you are to obtain maximum benefit from your primary training. Make your initial appearance, and each succeeding appearance before your instructor, a good one. Bear in mind that military courtesy and discipline are important factors in your training and will continue to be so as long as you are a member of the military service.
3. **Procedures.** Discuss with the instructor all of the preflight/post-flight items listed under Contact in the T-6B JPPT Curriculum.
4. **Common Errors.** Failure to know Preflight/Post-flight procedures.

404. PREFLIGHT PLANNING/BRIEFING

Prior to each flight, you will be scheduled for a brief (discussion) for that flight with your instructor. The Instructor Pilot (Pilot in Command) is responsible to perform and/or delegate preflight planning for the flight (i.e., weight and balance, fuel planning, obtaining weather brief, and filing flight plan as necessary). You will assist as directed, reporting results and noting any discrepancies. In later stages of training, you will be tasked with increasing responsibilities with preflight planning.

During the brief, the instructor will expect you to know the procedures for the maneuvers to be flown, along with any "discuss" items listed in the T-6B JPPT Curriculum. With respect to contact flight maneuvers, to "know" is to "memorize" (step by step, though not necessarily verbatim) each action of the procedure.

For emergency procedures, only asterisk items are required to be committed to memory, although you must have a thorough understanding of the remaining non- asterisk steps and the systems involved. ***You cannot prepare for your contact flights solely with this FTI.*** You must reference the T-6B NATOPS Flight Manual and other publications for emergency procedures (EP), systems, voice communications, and general information. You are highly encouraged to ask questions during the brief.

Your instructor will also brief the conduct of the flight in accordance with the briefing guide found on the back of the Pocket Checklist. Again, you are encouraged to ask questions. ***Do not go flying with an unanswered question on your mind.***

1. **Emergency Procedures/Discussed Items**

The Master Curriculum Guide (MCG) lists all maneuvers and items to be discussed for each flight. You should be prepared to answer in depth questions about any item listed under discussion. Ensure that you refer to any and all available resources when you are studying a particular item. For example, the FTI, T-6B NATOPS Flight Manual, Aeronautical Information Manual (AIM) and many ground school texts all contain information germane to your studies. Your instructor may quiz you on each discussion/demonstration and introduction item for that flight. Additionally, he/she may ask you about any maneuver previously introduced or any subject general in nature to the T-6B (systems, limitations, etc.). The T-6B JPPT Curriculum also has a listing of all emergency procedures to be discussed for each flight. The T-6B NATOPS Flight Manual lists these procedures.

2. **Headwork, Procedures, and Basic Airwork**

- a. **Headwork** - The ability to understand and grasp the meaning of instructions, demonstrations, and explanations; the facility of remembering instructions from day to day, the ability to plan a series or sequence of maneuvers or actions, the ability to foresee and avoid possible difficulties and the ability to remain alert and spatially oriented.

Headwork is the instructor's evaluation of the student's situational awareness (SA), and his or her ability to effectively manage the aircrew responsibilities. An example of a measure of headwork is whether the student remembers to "aviate, navigate, communicate" in the correct order. Another measure of headwork is whether the student is able to effectively communicate his or her SA. Headwork is purely a subjective item, and the student should never question the instructor's assessment of his or her headwork.

- b. **Procedures** - The demonstrated knowledge of the sequential steps required to perform the curriculum maneuvers and actions. Procedures are simply an instructor's evaluation of the SNA's ability to recall and/or apply the correct procedures to any situation. This may include emergency procedures, or such things as in-flight checks. It may also include compliance to course rules or squadron SOP. Procedures is a fairly straightforward item.
- c. **Basic Airwork** - Demonstrated mastery of the PCL and flight controls to obtain the desired attitude, heading, airspeed and altitude consistently through a range of maneuvers.

3. **Fuel Considerations** - The T-6B is usually not fuel limited on most training sorties; however, regular checks are still required and are an important part of each mission. Bingo fuel and at least one joker fuel is briefed on every mission.

- a. Joker fuel is set at pre-planned transition points in the sortie. For example, a Joker fuel of 750 lbs might be used to depart the working area to ensure enough fuel to

4-4 GROUND PROCEDURES

accomplish pattern operations. A mission may require several joker fuels.

- b. Bingo fuel is the fuel at which recovery should be initiated to arrive at the intended destination with the required fuel. On most T-6 syllabus training sorties, recovery is often initiated prior to reaching bingo fuel due to sortie duration limitations. Mission priorities and flight conditions may change while airborne (area assignment, weather conditions, alternate airfield requirements, etc.) The aircraft commander may adjust joker and/bingo fuels during flight to accommodate mission conditions.

405. PREFLIGHT INSPECTION

1. **Description.** N/A

2. **General.** The pilot who accepts an airplane for flight is in effect the commanding officer of that plane and is responsible for the efficient operation and safety of the aircraft, its equipment and its crew. Prior to every flight, a thorough preflight inspection must be performed.

A poor preflight may easily result in an embarrassing, if not dangerous, situation. Any pilot who thinks that there is a possibility that a discrepancy exists which would make the aircraft unsafe for flight should "down" the plane, inform maintenance of the trouble, and write a thorough and comprehensive description of the trouble on the Maintenance Action Form (MAF). Each pilot, in signing the aircraft acceptance form ("A-Sheet") prior to the flight, acknowledges acceptance of the aircraft in a satisfactory, safe-for-flight condition. He should always keep in mind that mistakes are sometimes made even by the most competent mechanics. The pilot must, therefore, make his inspection accordingly. ***Under no circumstances is a pilot required to accept an airplane unless it is satisfactory for flight operations in all respects.***

Regardless of the number of items you check on a preflight, you will forget something unless you follow a systematic pattern each time. For this reason, the Preflight procedure published in the T-6B NATOPS Flight Manual shall be used by all pilots.

3. **Procedures.** As you approach your aircraft, notice its position and the position of adjacent aircraft in relation to the yellow parking spots. An aircraft parked too far off the spots may have insufficient taxi clearance. Also note the position of fire bottles and other obstructions in relation to the path of your aircraft as you leave the chocks. Although a signalman will direct you out, you have the final responsibility to see that the aircraft clears all obstructions.

EJECTION SEAT SAFETY - "Respect the Seat." Think of this motto every time you get in and out of a T-6B or any other ejection seat airplane. Ejection seat and canopy fracturing system (CFS) safety is paramount during ground operations. ***If unintentionally or improperly fired, results could be fatal.*** Take extra care to ensure you and those around you never compromise ejection seat safety.

Upon initially opening the canopy, ensure all safety pins (ejection seat and CFS) are installed, per the checklist, and verbally confirm with your instructor. ***Never enter or exit the airplane without the ejection seat safety pins installed.*** With the pin(s) removed, always be conscious of

the ejection handle. Do not rest your hands on the ejection handle and never allow any equipment, such as kneeboards, checklists, and approach plates to interfere with it. Remember, “Respect the Seat.”

You are now ready to commence the Preflight Check (which includes the Before Exterior Inspection and the Exterior Inspection Checks) in accordance with the T-6B NATOPS Flight Manual. You will be expected to know nomenclature for all visible aircraft and engine components. Notify the other crew member of any problem areas discovered during the preflight inspection and if any corrective action has been taken/initiated, if necessary.

4. Common Errors.

- a. Taking too much time. Do not rush, but by the same token, move expeditiously.
- b. Pushing/pulling on the trim tabs, static wicks. Check, using only a slight amount of pressure.

406. STRAPPING IN TO THE SEAT

1. Description. N/A

2. **General.** Upon completion of the preflight inspection, your instructor will show you how to enter the cockpit, taking care not to step on the canopy rail. Respect the ejection seat. The T-6B is not a particularly simple aircraft to strap into and it is easy to forget one or more buckles or straps. Be patient, but precise; there is no fast way to do it. Reference Figure 4-2.

3. **Procedures.** Ensure all of the *harness buckles* are fastened and *G-suit zippers* are secure before entering. A good method is to start at your feet and work up. First plug in your G-suit, then fasten your leg garters and Lower Koch fittings. Attach the *main oxygen hose* and *emergency O₂ hose* to your CRU-60/P (before putting on the helmet) and then reach back, grab, and fasten the *parachute risers* to the *harness Upper Koch fittings*. You should now be ready to don the *helmet* and lower the *visor*. Attach the *oxygen mask hose* to the CRU-60 and plug into one of the two available **ICS cords**. Consult the T-6B NATOPS Flight Manual for Notes, Cautions, and Warnings during pilot hookup.

Each time you fly, your seat position should be the same. The electric seat adjustment switch is located on the left console behind the PCL. When seated in a relaxed posture the horizon should intersect a blue/purple line that is formed by the overlap of the HUD combiners. If turned on, the Waterline Pitch Reference should be level with the top of the line. Before exiting the aircraft, seat height should be noted to expedite future preflight set-up. When sitting upright in the simulator seat, line up the front edge of the instrument glare shield with the upper part of the instrument panel so that the top of the PFD is just visible. Adjust rudder pedals so you can get full forward throw of either pedal with the corresponding brake fully depressed without locking your knee.

NOTE

Take extra care to ensure no straps or buckles are entangled with any of the side panel switches or components before actuating the electronic seat adjustment to prevent inadvertent (and potentially very costly) damage to the ejection seat and/or cockpit side consoles.

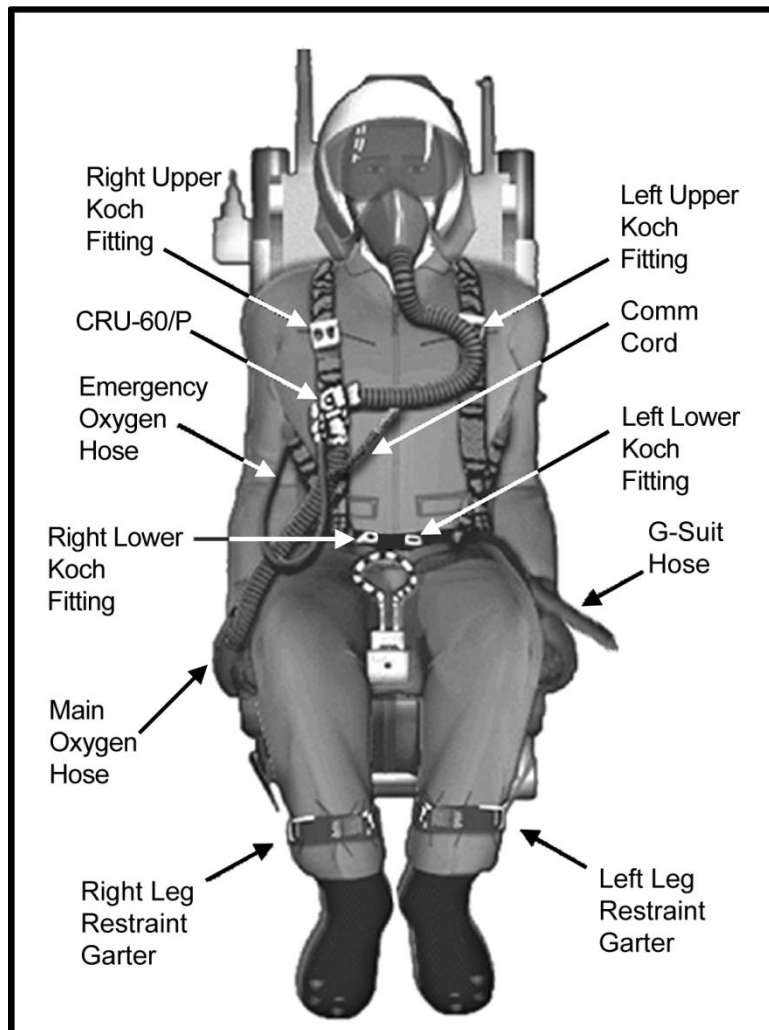

Figure 4-2 Strapping into the Seat

4. **Common Errors.**
 - a. Forgetting to zip up G-suit.
 - b. Forgetting to connect the chin strap.
 - c. Forgetting to lower the visor.

407. INTERIOR INSPECTION

1. **Description.** Cockpit (All Flights) Checklist.
2. **General.** The checklist will be conducted in the challenge-action-response format. This means that you state the challenge, take the required action, and then make the appropriate response.
3. **Procedures.** The checklist will be conducted in accordance with the pocket checklist.
4. **Common Errors.**
 - a. Missing items on checklist.
 - b. Taking too much time/rushing checklist.

408. STARTING PROCEDURE

1. **Description.** N/A
2. **General.** After completion of the Interior Inspection Cockpit Checklist, ensure the prop area is clear, a fire extinguisher is available, and the plane captain is ready for start. With the canopy closed and latched, check the green mechanical canopy lock indicator is visible (Figure 4-3) and the red CANOPY annunciator is extinguished. Complete the Engine Start (Auto) Checklist, conscious of any hazard indications from the plane captain.

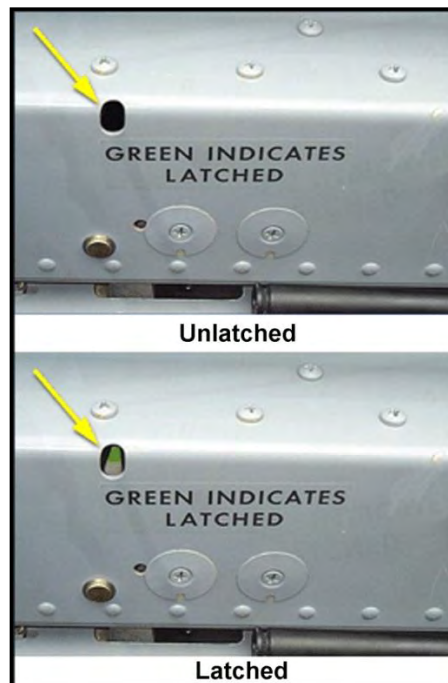

Figure 4-3 Canopy Lock Indicator

3. **Procedures.** Monitor the engine start sequence. If the power management unit (PMU) detects a malfunction, such as a hot or hung start, it will automatically terminate the start sequence. You should always be prepared to manually abort a start if the PMU fails to do its job and an abort is warranted. Complete the Engine Start and Before Taxi Checklists in accordance with the T-6B NATOPS Flight Manual.

During the Before Taxi Checklist, you will perform a brake check prior to releasing the lineman. Upon receiving the “release brakes” signal from the plane captain, clear left and right, and smoothly release brake pressure allowing the aircraft to move forward. When signaled, apply the brakes to bring the aircraft to a stop. Then pass control of the aircraft to the instructor who will complete his brake check. The instructor will then pass control of the aircraft back to you. Return the lineman’s salute, releasing them for other duties.

NOTE

Watch the lineman while the chocks are being removed or any time one approaches your aircraft. Keep both of your hands above the rails if ground crews are under the aircraft or near the flight controls surfaces.

4. Common Errors.

- a. Advancing the PCL past Start Ready.
- b. Failure to give thumbs-up to plane captain after good start.
- c. Fixating on one instrument (i.e., oil pressure) thereby failing to monitor all aspects of the start sequence.
- d. Failure to ensure positive change of controls during brake checks.
- e. Failure to adhere to lineman’s signals.
- f. Adding excess power for the brake check.

409. TAXIING

1. **Description.** Taxiing is the controlled movement of the aircraft on the ground under its own power.
2. **General.** Once the aircraft is running and all applicable checks are complete, we must safely taxi the aircraft from its starting point on the ramp to an active runway for takeoff. You should build the habit of always taxiing with the airfield diagram at your disposal (on your kneeboard, etc.). Have a taxi plan and know exactly where you are going before leaving the chocks. This becomes even more important later in the program as you begin to conduct training off-station (other than home field). Build good habits now.

Taxiways have a narrow yellow line painted down the middle. Taxi with the nose wheel on this line. This ensures a safe taxi clearance from fixed objects, such as parked airplanes and buildings. However, the aircrew is solely responsible for obstruction clearance. A general rule of thumb is to taxi no faster than a person can walk when within the line area and no faster than a trot when outside the line area.

3. **Procedures.** Taxiing in the T-6B uses power generated by the propeller, although not more than idle is normally needed. Speed is controlled with the brakes; power above idle may be required when initiating the taxi motion, traveling uphill, during sharp turns, etc. Directional control during taxi is accomplished by using the rudder pedals to manipulate the aircraft nose wheel steering (NWS) system, or by use of the rudder and/or differential braking. Keep your left hand on the PCL; keep your right hand on the control stick, facilitating ready access to the NWS button. Keep the ailerons deflected into the wind during taxi.

The Nose Wheel Steering (NWS) is the normal method to directionally control the T-6B. NWS is actuated by a button on the control stick (Figure 4-4) and verified by a green “NWS” advisory on the EICAS. With NWS on, the rudder pedals control the castoring of the nose wheel up to 12° either side of center. For turns requiring greater than 12° of nose-wheel castor, NWS must be disengaged and rudder and differential braking used to turn the aircraft.



Figure 4-4 Nose Wheel Steering Button

Clearing is essential to safe taxiing. People, support equipment, fuel trucks and fire bottles are among some of the most common hazards. When ready to taxi out of the line area, clear the taxiway, left and right, for other aircraft, fuel trucks, ground personnel, etc. Continually scan the

entire forward area from wingtip to wingtip. At any time, if there is doubt about obstruction clearance, STOP! Most taxi accidents are easily prevented if someone makes the right decision to stop and re-evaluate the situation.

4. **Common Errors.**
 - a. Not clearing area prior to starting to taxi.
 - b. Taxiing too fast.

410. OVERSPEED GOVERNOR CHECKLIST

1. **Description.** N/A
2. **General.** Engine checks are performed prior to each flight to determine the relative condition of the engine. These checks do not guarantee proper operation. They merely check for some of the more frequent causes of engine malfunction.
3. **Procedures.** The checklist will be conducted in accordance with the T-6B NATOPS Flight Manual.
4. **Common Errors.**
 - a. Omitting items from the checklist.
 - b. "Looking but not seeing" - calling an item checked/set when in fact it is not.

411. BEFORE TAKEOFF CHECKLIST

1. **Description.** N/A
2. **General.** Check and report each item on the Before Takeoff Checklist to your instructor. The importance of the Before Takeoff Checklist as a safety factor cannot be overemphasized. You will occasionally hear of pilots who take off with improper trim tab settings or other circumstances that contribute to accidents. This is invariably due to carelessness and haste in completing the checklist.
3. **Procedures.** The checklist will be conducted in accordance with the T-6B NATOPS Flight Manual.
4. **Common Errors.** Omitting items from checklist.

412. AFTER LANDING CHECKLIST

1. **Description.** N/A

2. **General.** Once clear of the duty runway, switch to Ground Control in accordance with local course rules and complete the After Landing Checklist. It is important not to get anxious during the landing rollout. Do not start the checklist until clear of the duty runway.
3. **Procedures.** After clearing the runway, switch to Ground Control and complete the checklist in accordance with the T-6B NATOPS Flight Manual.
4. **Common Errors.**
 - a. Switching to Ground Control or Starting Checklist prior to clearing duty runway.
 - b. Omitting items on checklist.
 - c. Forgetting to note the land time.

413. ENGINE SHUTDOWN CHECKLIST

1. **Description.** N/A
2. **General.** Once clear of the duty runway, taxi in accordance with course rules to the appropriate spot. Once the aircraft is stopped, focus your attention to the side of the aircraft that the lineman is on. This will allow you to detect movement of the aircraft, especially at night. Perform the Engine Shutdown Checklist in accordance with the T-6B NATOPS Flight Manual. The engine will be shutdown prior to the plane captain installing chocks.
3. **Procedures.** The checklist will be conducted in accordance with the T-6B NATOPS Flight Manual.
4. **Common Errors.**
 - a. Starting checklist prior to acknowledging plane captain.
 - b. Securing strobe lights/battery prior to prop stopping.

414. POSTFLIGHT CHECKS

1. **Description.** Checks conducted upon leaving the aircraft.
2. **General.** This inspection is designed to discover airborne damage or any discrepancies so that the necessary maintenance work may be performed promptly, with little or no delay of the aircraft going out on the next flight.
3. **Procedures.** The checklist will be conducted in accordance with the T-6B NATOPS Flight Manual.

4. Common Errors.

- a. Failing to perform walk-around inspection.
- b. Omitting items from the checklist.
- c. Leaving personal items (FOD), in the aircraft.

415. ALDIS LAMP SIGNALS

Aircraft with radio failure should observe the tower for light signals to obtain clearance to taxi, takeoff, land, etc. Acknowledge signals in the daytime by movement of ailerons or rudder on the ground and by rocking wings in the air. Acknowledge signals at night by flashing aircraft lights. Aldis lamp signals (Figure 4-5) from an airport traffic control light gun have meanings as indicated:

COLOR AND TYPE OF SIGNAL	ON THE GROUND	IN FLIGHT
STEADY GREEN	CLEARED TO TAKEOFF	CLEARED TO LAND
FLASHING GREEN	CLEARED TO TAXI	RETURN FOR LANDING (followed by steady green at the proper time)
STEADY RED	STOP	GIVE WAY TO OTHER AIRCRAFT AND CONTINUE CIRCLING
FLASHING RED	TAXI CLEAR OF RUNWAY	DO NOT LAND
FLASHING WHITE	RETURN TO STARTING POINT ON AIRPORT	NOT USED INFLIGHT
ALTERNATING RED AND GREEN	GENERAL WARNING SIGNAL. EXERCISE EXTREME CAUTION	GENERAL WARNING SIGNAL. EXERCISE EXTREME CAUTION
RED PYROTECHNIC	NOT USED ON THE GROUND	NOTWITHSTANDING ANY PREVIOUS INSTRUCTIONS, DO NOT LAND. WAVE OFF IMMEDIATELY!

Figure 4-5 Aldis Lamp Signals

THIS PAGE INTENTIONALLY LEFT BLANK

CHAPTER FIVE FLIGHT PROCEDURES

500. INTRODUCTION

This chapter discusses the basic procedures that you will practice at the beginning of your contact training. These basics will form the foundation of your ability to fly the aircraft and to later perform advanced maneuvers. You will learn to takeoff, fly straight and level, turn, climb and descend. You will even learn to stall and spin the aircraft. While some of these maneuvers, such as Straight-and-Level Flight, may seem simple, they all require strict adherence to the procedures contained in this chapter. In order to successfully learn to accomplish these maneuvers in the small amount of time that you will be airborne, it is essential that you commit these procedures to memory prior to strapping into the aircraft. If you do not know the procedures on the ground, you will not be able to perform them in the air. Some procedures, such as the spin, require extra care and preparation due to the dynamic and possibly disorienting nature of the maneuver.

501. CONTACT FLIGHT TERMINOLOGY

FAST CRUISE	240 KIAS / Clean Power as required (~80%) / 1° Nose Down
NORMAL CRUISE	200 KIAS / Clean Power as required (~54%) / 0° Nose Up
SLOW CRUISE	150 KIAS / Clean Power as required (~33%) / 3.5° Nose Up
NORMAL CLIMB	180 KIAS / Clean MAX Power, 100% / 8° Nose Up
TERMINAL ROUTE DESCENT	200 KIAS / Clean Power 20% / 5° Nose Down
NO-FLAP CONFIGURATION	120 KIAS / Gear Down, Flaps Up Power as required (~31%) / 4° Nose Up
TAKEOFF FLAP CONFIGURATION	120 KIAS / Gear Down, Flaps TO Power as required (~42%) / 3° Nose Up
LANDING FLAP CONFIGURATION	120 KIAS / Gear Down, Flaps LDG Power as required (~52%) / 1° Nose Up

Figure 5-1 Contact Flight Terminology

NOTE

Power settings are approximate and will vary with aircraft weight, altitude, etc. Make corrections as needed. Throughout this manual, when mandated by procedure to establish a specific power setting, a power setting within $\pm 3\%$ is acceptable. The only exception is for procedures that mandate a 4-6 % power setting to simulate the feathered condition.

502. OPERATIONS CHECKS

Accomplish the operations check to ensure various aircraft systems are operating properly. For safety considerations, complete an operations check at least once every 20 minutes in flight, with the first check being accomplished during the initial departure climb.

503. ASSUMING CONTROL OF THE AIRCRAFT

It is critical to flight safety that a pilot be at the controls of the aircraft at all times. A misunderstanding between two pilots as to who is actively controlling the aircraft could become a causal factor in a mishap. Therefore, you must be knowledgeable of the procedures involved in transferring controls. Throughout your flying career, you will fly with many pilots of various experience levels and backgrounds. To avoid miscommunication, all pilots transfer the controls the same way, regardless of platform.

Either pilot may initiate a change in control of the aircraft. It shall be accomplished by means of a positive three-way exchange using the word "controls."

NOTE

Do not use the words "it," "aircraft," or "command" to refer to the controls.

For example, the instructor may initiate by telling you over the ICS, "I have the controls." You will then acknowledge by saying over the ICS, "You have the controls." You will then take your hands and feet off the controls and your instructor will confirm he has control by saying, "I have the controls."

When your instructor wants you to take control, he will say, "You have the controls," whereupon you will take control and acknowledge by saying over the ICS, "I have the controls." Your instructor will complete the three-way exchange with, "You have the controls."

Stay on the controls and keep flying the aircraft until you are told to do otherwise. Never be in doubt as to who is doing the flying. Always fly as if you are flying solo unless you know that the instructor has control. The important thing is that a "demand and reply" series of responses is used so that there is no question as to who is flying.

NOTE

In the event of ICS failure, the pilot requesting control will shake the control stick, and the pilot relinquishing control will raise both hands. The pilot at controls will shake the control stick again to confirm he/she has controls.

504. COMMUNICATIONS

Proper radio communication procedures are extremely important to safety when operating in controlled airspace or the vicinity of other aircraft. You should read and learn the basic communication terminology/procedures explained in Appendix B. These procedures will be used throughout your aviation career.

505. TAKEOFF

1. **Description.** Takeoff is the movement of the aircraft from its starting point on the runway until it leaves the ground in controlled flight.

2. **General.** The takeoff requires a smooth transition from ground roll to controlled flight. Although a relatively simple maneuver, the takeoff presents numerous potential hazards. The dynamics of high engine thrust, possible directional control problems, the potential for runway incursions, high-speed aborts, low-altitude engine failures, to name a few, make the takeoff regime of flight unique in its safety challenges. Thorough and disciplined ground operations help lead to a safe, uneventful takeoff.

Takeoffs should always be made as nearly into the wind as practical. The aircraft's ground speed in a headwind is slower at liftoff than in a tailwind, thus reducing wear and stress on the landing gear. Secondly, a shorter distance is required to develop the minimum lift necessary for takeoff and climb. Aircraft depend on airspeed to fly. A headwind provides some airspeed before the aircraft even begins its takeoff ground roll as the wind flows over the wings.

Although the takeoff and climb process is one continuous maneuver, it is divided into three separate steps for purposes of explanation: takeoff roll, rotation, and initial climb (Figure 5-2).

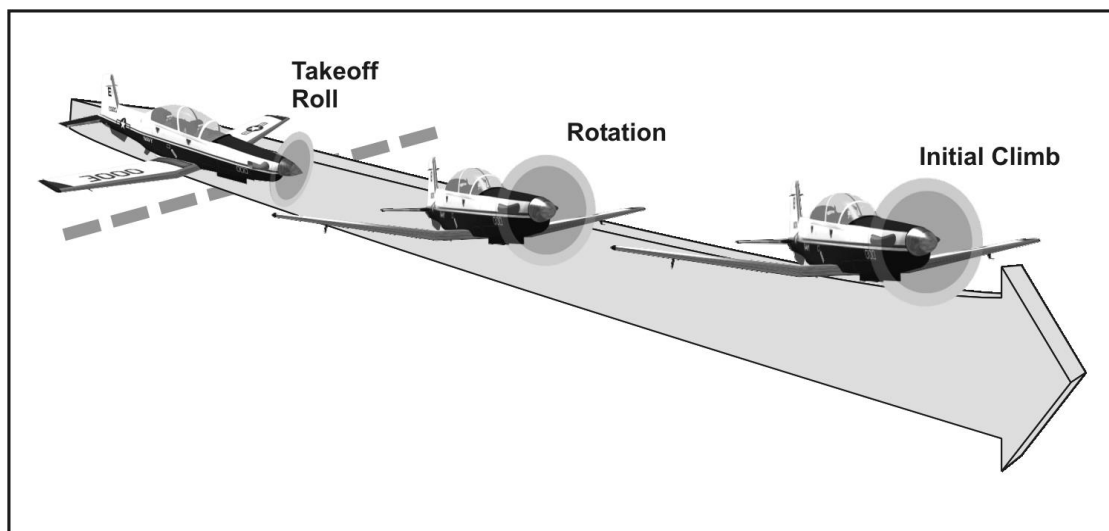

Figure 5-2 The Takeoff Roll, Rotation, and Initial Climb

The takeoff roll is the portion of the takeoff procedure during which the aircraft is accelerated from a standstill to an airspeed providing sufficient lift for it to become airborne.

The rotation is the act of raising the nose of the aircraft to a set pitch attitude, increasing AOA and allowing the aircraft to become airborne in controlled flight.

The initial climb is the period just after the aircraft has left the runway and is normally considered complete when the aircraft has reached a safe maneuvering altitude.

During the takeoff, an abrupt application of power will cause the aircraft to yaw sharply left because of the torque effects of the propeller. Steady the yawing tendency with right rudder as the engine spools up and the aircraft begins rolling down the runway. Remember, the TAD will not begin making rudder trim adjustments until 80 KIAS and weight off wheels. As speed increases, more and more pressure will be felt on the flight controls, particularly the elevator and rudder. Since the tail surfaces receive the full effect of the propeller slipstream, they become effective first.

To rotate, apply back stick pressure at 85 KIAS to gradually raise the nose wheel off the runway and establish the takeoff attitude (8° nose high, spinner on or slightly below the horizon). This is referred to as “rotating.” Allow the aircraft to fly itself off the ground. Do not force the aircraft into the air with excessive back-stick pressure as this will only result in an excessively high pitch attitude, possible stall or tail strike. Coordinate right rudder as necessary with TAD adjustments during rotation. Compensate for the left yaw tendency as the aircraft leaves the runway with rudder, not aileron.

As you move to the initial climb phase of the takeoff, check pitch attitude at approximately 8° nose high and begin accelerating. The aircraft will pick up speed rapidly after becoming airborne. Once a positive climb is verified and a safe landing cannot be made on the remaining runway in front of you, raise the gear and flaps (as per After Takeoff Checklist and the procedures below). Accelerate to 140-180 KIAS and climb.

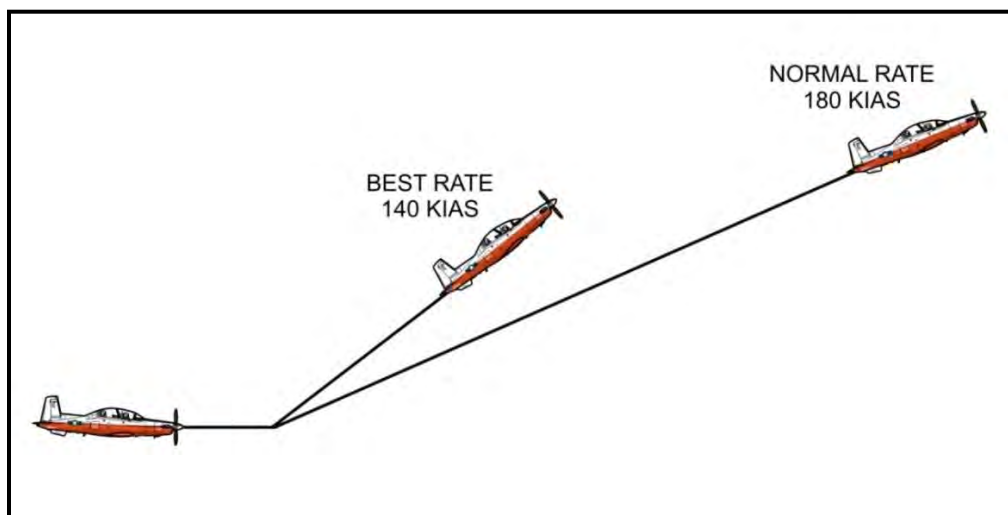

Figure 5-3 Climb Rate

NOTE

More efficient climbs may be required for obstacle clearance or other requirements such as noise abatement or cloud avoidance. The T-6B best rate of climb speed is 140 KIAS and 15° nose high (Figure 5-3).

Since power during the initial climb is fixed at maximum, airspeed must be controlled with slight pitch adjustments. However, do not stare at the airspeed indicator when making these slight pitch changes; crosscheck airspeed to confirm the correct pitch picture in relation to the horizon is set.

For takeoff in crosswind conditions, the aircraft will tend to weather-vane into the wind and the upwind wing will begin to rise even in light-to-moderate crosswinds. This tendency can be controlled with rudder and aileron. Maintain positive aileron deflection into the wind once in position for takeoff, and maintain this crosswind control throughout the maneuver. Use up to full aileron deflection into the wind at the beginning of the takeoff roll, and relax aileron input as speed increases to the amount required to keep wings level at liftoff. Use rudder as necessary to maintain centerline. Realize that a left crosswind will add to the aircraft's left yawing tendency due to engine torque effect, requiring even more right rudder to maintain directional control. Once the aircraft has safely left the runway in controlled flight, level the wings, allow the aircraft to crab into the wind, and check balance ball centered.

3. Procedures.

- a. Approaching the hold short line (approximately 200 feet prior) switch to Tower frequency.
- b. When appropriate, and in accordance with the SOP, call the tower for takeoff clearance. Prior to making this call, listen carefully to avoid cutting out other transmissions. Instructions to "Lineup and wait" or "Hold short" must be read back. Clearance for takeoff will be acknowledged with, "Call sign, cleared for takeoff." Upon receiving takeoff clearance, taxi into the takeoff position in accordance with local course rules.
- c. After acknowledging tower's "Cleared for takeoff" or "Lineup and wait" call, visually clear final, then begin taxi to the takeoff position and initiate the Lineup Checklist. Verbally note right to left or left to right crosswinds as called out by tower. Verify with windsock, if available.
- d. Align the aircraft on runway centerline and come to a stop using the brakes. With the nose wheel centered, disengage the nose wheel steering and complete the Lineup checklist. Once cleared for takeoff, increase torque to ~30% and check engine instruments. Report over the ICS, "Instruments checked." Confirm instruments checked in the rear cockpit as well.

- e. Select a reference point. Position the elevator neutral to slightly aft of neutral. For crosswinds, position aileron as required into the prevailing winds. To compensate for torque effect in zero crosswind conditions, add slight right aileron at MAX power. Release brakes, dropping your heels to the deck (toes off the brakes).

NOTE

Select a reference point on centerline and towards the end of the runway and beyond. Keep the nose pointed toward this reference throughout ground roll and rotation to aid directional control.

- f. Release the brakes and allow the plane to roll forward momentarily to ensure the nose wheel is centered. Smoothly advance the PCL to MAX in 2 to 3 seconds. Anticipate the need for right rudder as the engine spools up. Maintain directional control.
- g. At 60 KIAS, check torque is at or above minimum power calculated on the Before Takeoff Checklist. If not, abort the takeoff. Verbalize over the ICS "60 knots, XXX%."
- h. At 85 KIAS, smoothly apply back-stick pressure and position the nose to takeoff attitude (spinner on or slightly below the horizon). Allow the aircraft to fly itself off the deck.

NOTE

If gusty winds are present, increase rotation speed by 1/2 the gust factor (up to 10 KIAS). For example, if winds are reported at 10 gust 22 (i.e., 12-knot gust factor), rotate at 91 KIAS ($85 + 1/2(12) = 91$). This is independent of wind direction.

- i. When a safe landing can no longer be made, check for two positive rates of climb (ALT and VSI) and airspeed below 150 KIAS. Report over ICS, "Two positive rates, Gear," then raise the gear. When airspeed is above 110 KIAS, Report over ICS, "Airspeed above 110 KIAS, Flaps." then raise the flaps (as per After Takeoff Checklist). Report over the ICS, "Gear up, flaps up at __ knots."

NOTE

Retraction of flaps from the TO to the UP position is not recommended below 110 KIAS to preclude the aircraft from settling back to the runway. However, there is no minimum to raise the flaps from the LDG to TO position once safely airborne.

- j. Check nose attitude at 8° nose high and continue acceleration, trimming as necessary. Approaching 180 KIAS, set the 180 knot climbing attitude and climb out in accordance with local course rules or departure procedures.

4. Common Errors.

- a. Failure to maintain directional control on takeoff roll through improper use of rudder.
- b. Not assuming the takeoff attitude at approximately 85 knots (or as calculated for wind gusts).
- c. Not relaxing back-stick pressure as necessary to maintain takeoff attitude, hence over-rotating.
- d. Pulling aircraft off the deck prematurely or over-controlling.
- e. Swerving or skipping on takeoff roll due to improper use of crosswind correction.
- f. Applying insufficient right rudder on liftoff and attempting to correct with right wing low.
- g. Failure to trim left rudder, nose down after gear are retracted and airspeed increases.
- h. Failure to report "Gear up, flaps up at ___ knots."

506. CROSSWIND TAKEOFF**1. Description.** N/A

2. General. The procedures for a takeoff with a crosswind are the same as for a no wind takeoff, except aileron is held into the wind to keep the wings level. Aileron deflection is necessary because the upwind wing develops more lift, causing it to fly (begin rising) before the downwind wing. If the upwind wing rises, skipping may result (Figure 5-4). Skipping is a series of very small bounces caused when the aircraft attempts to fly on one wing and settles back onto the runway. During these bounces, the aircraft moves sideways and stress on the landing gear is increased. Anticipate aileron requirement due to the crosswind and either pre-position aileron into the wind or apply aileron into wind as required during takeoff roll. Use rudder to keep the aircraft from weather-vaning (for example, crabbing or turning into the wind). The flight controls become more effective as airspeed increases, so progressively smaller control inputs are required to maintain aircraft control.

As the airplane is taxied into takeoff position, mentally note the winds as called by tower (also check the windsock and other indicators) so that the presence of a crosswind may be recognized and anticipated. Aileron should be held into the wind as the takeoff roll is started. As the airspeed increases and the ailerons become more effective, adjust the aileron inputs to maintain the wings level.

Firmly rotate the aircraft off the runway when flying speed is reached to avoid side-slipping and damage to the tires. Once the aircraft has become airborne, initial drift correction is made by turning into the wind with a shallow bank, then rolling wings level to maintain runway centerline

(crabbing).



Figure 5-4 Skipping on Takeoff

507. DEPARTURE

1. **Description.** N/A
2. **General.** See local Standard Operating Procedures or Course Rules.
3. **Procedures.** See local Standard Operating Procedures or Course Rules.

508. STRAIGHT AND LEVEL FLIGHT

1. **Description.** Maintain a constant altitude, airspeed and heading using the horizon as the primary reference.
2. **General.** Straight-and-level flight requires familiarity with flight instruments and visual cues. To fly in level flight, consciously fix reference points on the aircraft in relation to the horizon, and compare or crosscheck this relationship with the flight instruments. In addition to outside references, refer to the PFD to crosscheck the altimeter, and vertical speed indicator.

In straight-and-level unaccelerated flight at 200 KIAS, the level flight visual pitch picture is approximately half-ground/half-sky with the wings equidistant from the horizon, (Figure 5-5). At higher airspeeds, hold the nose at a lower attitude to maintain level flight; at lower airspeeds, hold the nose at a higher attitude. Straight and level flight is a balanced flight condition while maintaining a constant heading and altitude.

5-8 FLIGHT PROCEDURES



Figure 5-5 Straight and Level Flight

Familiarity with the design, location and purpose of flight instrumentation speeds up the composite cross check and aids in detecting small deviations (while they are still small). Good aircraft control is a continuous succession of minor, almost imperceptible corrections to keep the aircraft on the desired flight path.

When straight and level, trim the aircraft in all three axes. A trim change is necessary when continuous control stick or rudder pressure is required to maintain the desired attitude. Straight-and-level flight requires almost no pressure on the controls if the aircraft is properly trimmed and the air is smooth; however, when flying through turbulence, the flight attitude may change abruptly.

A properly trimmed aircraft is trimmed for a specific airspeed. It flies at the trimmed airspeed hands-off; that is, with little or no force applied to the control stick or rudders. Changes to airspeed require additional trim input potentially in all three axes, but predominantly in elevator and rudder (pitch and yaw) trim. For example, if the PCL is retarded to slow from 200 to 120 KIAS in level flight, the nose of the aircraft drops to seek 200 KIAS. Back-stick pressure is required to maintain level flight until nose up trim relieves the back-stick pressure. A trimmed aircraft reduces pilot fatigue and allows the pilot to devote more attention to task management and development of situational awareness on events occurring outside the cockpit. Large changes in airspeed in a short amount of time will require large changes in elevator trim and will require running the trim or holding the trim button forward or aft. After heavy forces are trimmed off, a method to fine tune the trim is to loosen the grip on the control stick and note the

direction that the nose or wings travel. Apply trim in the opposite direction to nose or wing movement (for example, if the nose drops apply aft elevator trim, if the aircraft rolls left apply right aileron trim).

A common error in straight-and-level flight is to apply force to the control stick inadvertently due to the weight of the pilot's arm. Minimize this by resting the forearm on the thigh.

a. **To achieve straight flight (constant heading)**

- i. **VISUAL:** The pilot selects two or more outside visual reference points directly ahead of the airplane (such as fields, towns, lakes, or distant clouds, to form points along an imaginary line) and keeps the airplane's nose headed along that line. Roads and section lines on the ground also offer excellent references. Straight flight can be maintained by flying parallel or perpendicular to them.

Straight flight (constant wings level attitude) may also be accomplished by visually checking the relationship of the airplane's wingtips with the horizon. Both wingtips should be equidistant below the horizon, and any necessary adjustments should be made with the ailerons, noting the relationship of control pressure and the airplane's attitude.

- ii. **INSTRUMENT:** An occasional check of the heading indicator should be made to determine that the airplane is actually maintaining flight in a constant direction.
- iii. **CORRECTIONS:** Whenever an error in heading is noted, first stop the error and stabilize, then correct back to proper heading. As a rule of thumb, the angle of bank used for heading corrections should not exceed the number of degrees you want to turn. Lead the rollout on heading by the "one-third rule" (by the number of degrees equal to one-third the angle of bank). This lead in rollout will preclude turning beyond the desired heading.

Continually observing the wingtips has advantages other than being a positive check for leveling the wings. It also helps divert the pilot's attention from the airplane's nose, prevents a fixed stare, and automatically expands the radius of visual scanning. In straight-and-level flight, the wingtips can be used for both estimating the airplane's angle of bank, and to a lesser degree, its pitch attitude.

In balanced flight, any time the wings are banked, the airplane will turn. Thus, close attention should be given to the wing position and attitude indicator to detect small indications of bank, and to the heading indicator to note any change of direction.

When the wings are approximately level, straight flight can be maintained by simply exerting the necessary forces on the rudder in the desired direction. However, the practice of using rudder alone is not a "normal" method of aircraft

control and may make precise control of the airplane difficult.

Straight-and-level flight requires almost no application of control pressure if the airplane is properly trimmed and the air is smooth. For that reason, the pilot must not form the habit of moving the controls unnecessarily.

When practicing this fundamental flight maneuver, the pilot should trim the airplane so it will fly straight and level without assistance. By using the trim tabs to relieve all control pressures, the pilot will find that it is much easier to hold a given altitude and heading. The airplane should be trimmed by first applying control pressure to establish the desired attitude, and then adjusting the trim so that the airplane will maintain that attitude without control pressure.

b. **Corrections in Straight-And-Level Flight**

There are several methods for correcting a deviation from desired altitude/airspeed when maintaining level flight. These consist of a power correction, or a power and attitude correction with a continual need for re-trimming.

- i. **Off airspeed/on altitude.** If you note that the altitude is being maintained, but the airspeed is slow or fast, a power adjustment is necessary, since power controls airspeed in level flight. Remember each torque setting given in this manual is a suggested starting point. Once the appropriate power setting has been changed, a change in the pitch may be required to maintain the attitude for level flight and, as always, re-trim.
- ii. **Off airspeed/off altitude.** If you have a high airspeed and a loss of altitude or a low airspeed and a gain in altitude, it is the result of not maintaining the proper nose attitude. Stop the loss or gain by resetting the level flight attitude, then correct by trading the excess altitude or airspeed to return to the desired altitude and airspeed. Re-trim.
- iii. **On airspeed/off altitude.** If you note that you are 100 feet high, yet the airspeed is correct, correct to altitude by reducing the power slightly and allow the nose attitude to lower just slightly so the aircraft will descend back to the desired altitude. Once returned to altitude, reset normal cruise power setting and re-trim.

3. **Procedures.**

- a. Maintain balanced flight. Trim.
- b. Set the nose position for straight and level by visually bisecting the windscreen with the horizon. Crosscheck the altimeter and VSI. Trim.
- c. Set the wing position for straight and level flight by setting the wingtips equidistant

- below the horizon. Crosscheck the heading. Trim.
- d. Continue a working scan and if an error is recognized, make proper corrections.
 - e. If an error in altitude is noted on the altimeter, stop the error by adjusting the nose attitude. Then, using coordinated power and stick pressure, adjust back to desired altitude. Re-trim.
 - f. If an error is noted in heading, stop the drift by leveling the wings. Turn back towards the desired heading, never using a greater angle of bank than the number of degrees off heading. Re-trim.

4. **Common Errors.**

- a. Over-controlling: Making control movements too great for the amount of correction necessary.
- b. Not recognizing a wing low or nose attitude too high or too low.
- c. Fixating. Not maintaining a good scan.
- d. Not re-trimming.

509. **BASIC TRANSITIONS**

1. **Description.** Basic transitions are used to initiate and/or level off from a climb or descent. The following are the four basic transitions: climb-to-cruise, cruise-to-climb, cruise-to-descent, and descent-to-cruise.
2. **General.** Use the P.A.T. principle to make all transitions. Because trim is so vital to this section, now would be a good time to review the Trim Requirements discussion in Chapter two.

When not in radar contact, during climbs and descents greater than 1000 feet a constant integrated scan outside and reference to TCAS shall be used to clear traffic around you. S-turns may be used during descent to clear below the flight path if required.

Your cockpit references will vary by the type of transition. During climbs and descents, the airspeed indicator becomes the nose attitude crosscheck instrument. The heading indicator remains the crosscheck for wings level (constant heading). When leveling off from a climb or descent, the altimeter and vertical speed indicator become the nose attitude crosscheck instruments.

510. **PROCEDURES**

1. **Cruise-to-Climb Transition:**

- a. *Power* - smoothly advance power to MAX.
- b. *Attitude* - raise the nose to 12-15° nose high (nose attitude slightly above the 180-knot climbing attitude shown in Figure 5-6).
- c. *Trim* as required and commence clearing turns as appropriate.
- d. As airspeed decreases to 180 KIAS, lower nose slightly to the normal climbing attitude, 8° nose high (Figure 5-6).
- e. Re-trim as necessary to remove all pressures from the flight controls and check balance ball centered.



Figure 5-6 Climb Attitude ~8° Nose High

NOTE

As described in the following procedures, climbs greater than 1000 feet are accomplished at the normal 180 KIAS, accompanied by clearing turns. Climbs of 1000 feet or less will be done at MAX power and cruise airspeed (200 or 240 KIAS) without clearing turns. In order to maintain airspeed, cruise airspeed climbs necessitate milder pitch changes than described in the procedures below.

2. Climb-to-Cruise Transition:

- a. 200 feet prior to level-off altitude, begin lowering nose toward the level flight attitude.

- b. Trim for acceleration.
- c. Five knots prior to desired cruise airspeed:

Power – smoothly reduce to normal cruise, 54% (fast cruise, 80%).

Attitude – set level flight picture.

Trim as necessary to remove all pressures from the flight controls and check the balance ball centered (coordinated flight).

3. **Cruise-to-Descent Transition:**

- a. *Power* – smoothly reduce to 20%.
- b. *Attitude* – lower nose to the en route descent nose attitude (~5° Nose Low).
- c. *Trim* for power reduction and commence clearing turns as appropriate.
- d. Re-trim as necessary to remove all pressures from the flight controls and check the balance ball centered.

4. **Descent-to-Cruise Transition:**

- a. Passing 100 feet prior to level-off altitude, simultaneously:

Power – advance to normal cruise ~54% (fast cruise, 80%).

Attitude – raise the nose to level flight picture.

Trim for power addition.

- b. Re-trim as necessary to remove all pressures from the flight controls and check the balance ball centered.

5. **Common Errors.**

a. **Cruise-to-Climb Transition:**

- i. Not concentrating on horizon and remaining scan. Use your peripheral vision.
- ii. Not trimming as airspeed slows.
- iii. Overcorrecting nose attitude for airspeed error. If the aircraft is off airspeed, check torque at MAX allowable, readjust the nose and re-trim.

- iv. Not performing clearing turns (when required).
- b. **Climb-to-Cruise Transition:**
 - i. Lowering the nose to the level flight attitude immediately instead of **TOWARDS** the level flight attitude. Remember, the airspeed is still slow.
 - ii. Not trimming during the transition.
- c. **Cruise-to-Descent Transition:**
 - i. Rushing the maneuver.
 - ii. Not trimming properly.
 - iii. Not performing clearing turns (when required).
 - iv. Not setting/holding sufficient nose down, thereby getting slow.
- d. **Descent-to-Cruise Transition:**
 - i. Moving nose first. Remember P.A.T.
 - ii. Under-trimming the nose and continuing in a descent.

511. CONSTANT ANGLE OF BANK TURNS

1. **Description.** Turn the aircraft using a constant angle of bank to an assigned heading while maintaining altitude and airspeed.
2. **General.** When you perform constant angle of bank turns (CABT), your instructor will state the desired angle of bank and rollout heading. Before commencing any turn, look in the direction of the turn to ascertain that the area is clear of clouds and other aircraft. If clear, commence the turn. Throughout this maneuver, a rapid and consistent scan pattern is a necessity.

During the turn, continue to check the area clear, check the aircraft attitude with the horizon, then crosscheck the PFD for nose attitude with the altimeter and VSI, and the angle of bank with the attitude indicator. Correct the visual attitude as necessary, while periodically cross-checking the heading indicator for turn progress and the airspeed for power required.

To prevent turning beyond the desired heading, it is necessary to anticipate or lead this new heading by using the one-third rule. This rule will be used during all turns to specified headings.

3. **Procedures.**

- a. Clear the area.
- b. Roll into an estimated angle of bank on the horizon; add slight rudder in direction of turn to maintain a centered ball, then crosscheck that angle of bank on the attitude gyro throughout the turn.
- c. Adjust power and nose attitude as necessary and re-trim for the correct altitude and airspeed, (P.A.T.).
- d. Roll out of the turn on the desired heading by leading the turn with the one-third rule.
- e. Reset straight and level and re-trim.

4. **Common Errors.**

- a. Inattention to performance, (i.e., maintaining altitude but not adding any power to maintain airspeed). Power + Attitude = Performance
- b. Not maintaining a constant angle of bank.
- c. Losing altitude in steep turns.
- d. Lack of trim.
- e. Not clearing the area prior to and during the turn.

512. TURN PATTERN

1. **Description.** The turn pattern (TP) is a series of constant angle of bank turns while maintaining altitude and airspeed.

2. **General.** The TP is started in normal or slow cruise on any numbered heading. The TP consists of two 30° angle of bank turns in opposite directions for 90° of heading change, two 45° angle of bank turns in opposite directions for 180° of heading change, and two 60° angle of bank turns in opposite directions for 360° of heading change. A smooth reversal is made going from one turn into another, eliminating a straight and level leg (Figure 5-8). Your IP may adjust the TP as needed to remain within the working airspace.

During the turns, continue to check the area clear. Check the aircraft attitude with the horizon, then crosscheck the PFD for nose attitude with the altimeter and VSI, and the angle of bank with the attitude indicator. Correct the visual attitude as necessary, while periodically cross-checking the heading indicator for turn progress and the airspeed for power required.

The 30° angle of bank turns will require little back-stick pressure or additional power. For the 45° and 60° angle of bank turns, it will be necessary to raise the nose slightly to increase the angle of attack in order to compensate for the loss of vertical lift as the bank steepens.

Additional power will be required to maintain airspeed. To avoid overshooting the rollout headings, lead the rollout heading by a number of degrees equal to one-third the angle of bank (for a 30° angle of bank turn, lead the rollout by 10°). Strive for smooth reversals between turns. Trim the aircraft as necessary throughout the pattern. Remember, as the reversal or rollout occurs, the nose must be lowered back to the level attitude, and since it has been trimmed "up" during the turn, the nose will require forward stick pressure to lower it. Remember to use the P.A.T. principle.

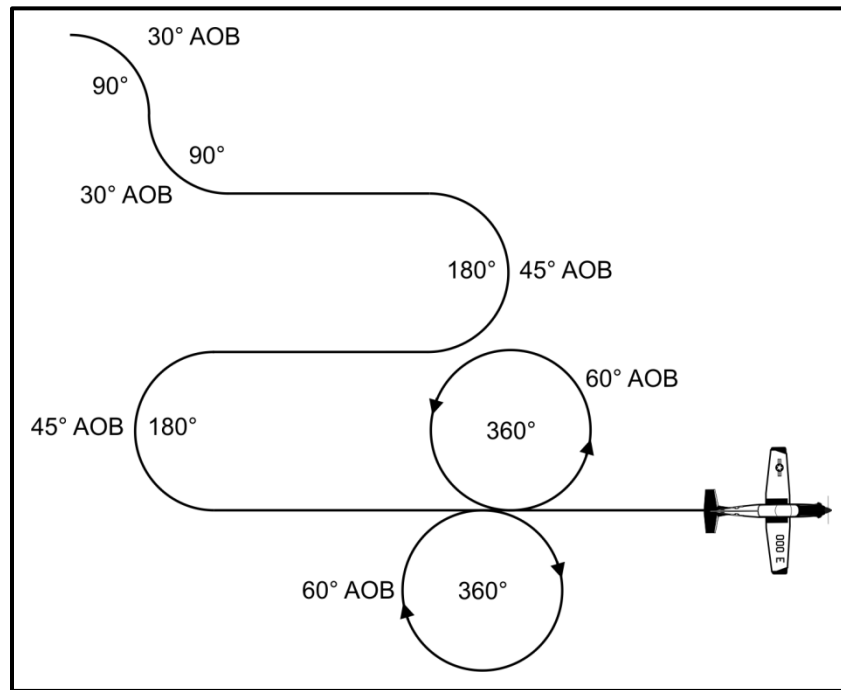

Figure 5-7 Turn Pattern

3. Procedures.

- a. Establish the aircraft straight and level on any numbered heading, base altitude and normal or slow cruise.
- b. Clear the area. Turn either direction for 90° of heading change using a 30° angle of bank. Clear the area (in the other direction), then reverse the turn, leading by the one-third rule for 90° of heading change using a 30° angle of bank.
- c. Clear the area. Reverse the turn leading by the one-third rule and turn for 180° of heading change using a 45° angle of bank. Maintain altitude and airspeed with power and nose attitude; trim. Clear the area (other direction), then reverse the turn using the one-third rule for 180° of heading change using a 45° angle of bank. Remember to adjust nose attitude as necessary to maintain airspeed and altitude while rolling through wings level.
- d. Clear the area. Reverse the turn leading by the one-third rule and turn for 360° of

- heading change using a 60° angle of bank. Adjust power and nose attitude to maintain altitude and airspeed; trim. Clear the area (other direction), then reverse the turn leading by the one-third rule. Hold slight forward stick pressure to prevent ballooning as you roll through the wings level. Reestablish the attitude to maintain altitude; turn for 360° of heading change using a 60° angle of bank.
- e. Roll out on the original heading using the one-third rule and holding slight forward stick pressure to prevent ballooning.
 - f. Reset power to the normal cruise power setting (as required), reset attitude and re-trim for straight and level flight.

4. Common Errors.

- a. Applying the control pressures too rapidly and abruptly, or using too much back-stick pressure before it is actually needed. Remember the aircraft is flown through a medium-banked turn before it reaches a steeper turn.
- b. Not holding the nose attitude steady. In order to determine the appropriate corrections, you must first establish a steady attitude and allow the instruments to stabilize.
- c. Staring at the nose and consequently applying control corrections too late. Divide your attention. Scan your instruments, never fixating on any one instrument. Anticipate the need for additional power and nose up. Do not wait until you are low or slow.
- d. Gaining altitude in reversals. Not lowering nose as the wings pass the level flight attitude, usually due to fixating on the PFD instead of scanning the horizon.
- e. Not clearing the area before and during all turns.
- f. Not flying in balanced flight.

513. LEVEL SPEED CHANGE

1. **Description.** Level speed changes (LSC) are taught to familiarize you with the various trim adjustments required with changes in airspeed, power setting, and aircraft configuration.
2. **General.** The LSC maneuver will be commenced on any assigned heading. The sequence is flown from normal cruise (200 KIAS) to the downwind configuration (120 KIAS), to the landing flap approach configuration (110 KIAS), and then to normal cruise (200 KIAS). Because of the numerous tasks associated with these transitions, a good outside visual scan pattern cannot be overemphasized. You will experience changes in aircraft attitudes and control pressures during each transition. Your instructor will require you to fly the aircraft at various angles of bank in the downwind and landing approach configurations to experience the way in

which the aircraft handles at these slower airspeeds. During these turns, additional power must be applied to maintain airspeed, with attitude adjustment to maintain altitude.

3. **Procedures.**

- a. Establish the aircraft in the normal cruise configuration (200 KIAS) on any numbered heading.
- b. Reduce power to idle. Trim for deceleration. When airspeed is below 150 KIAS, lower the landing gear.
- c. As the airspeed approaches 120 KIAS, adjust power to ~31% to maintain 120 KIAS.
- d. Stabilize aircraft in the downwind configuration. Trim off control pressures.

NOTE

Your instructor may want you to practice a few shallow turns in this configuration prior to continuing. Remember, you will see this nose attitude on the downwind leg when you begin practicing the landing pattern.

- e. Lower Landing flaps. As airspeed approaches 110 KIAS, advance power to ~ 50% and stabilize in the landing flap approach configuration. Trim.
- f. Complete the Before Landing Checklist over the ICS.
- g. Advance power to maximum, check airspeed below 150 KIAS, and raise the gear and flaps. Report over the ICS, "Gear up, flaps up at ___ knots." Trim for acceleration.
- h. Accelerate to normal cruise. As airspeed approaches 200 KIAS, reduce power to ~54%.
- i. Re-trim as necessary to remove all pressures from the flight controls and check the balance ball centered.

4. **Common Errors.**

- a. Failure to properly trim rudder pressures, resulting in poor heading control.
- b. Commencing the Before Landing Checklist in the middle of a transition, resulting in poor basic airwork.
- c. Failure to maintain proper nose attitudes associated with configuration.
- d. Failure to properly trim elevator pressure, resulting in poor altitude control.

514. STALLS

1. **Description.** Stalls are taught to develop your ability to recognize a complete stall or an approaching stall and to recover correctly with a minimum loss of altitude.
2. **General.** You will learn to recognize the approaching stall or complete stall through a combination of the senses of sight, sound and feel.
 - a. Vision is useful in detecting a stall condition by noting the attitude of the airplane. This sense can be fully relied on only when the stall is the result of an unusual attitude of the airplane. However, since the airplane can also be stalled from a normal attitude, vision in this instance would be of little help in detecting the approaching stall.
 - b. Hearing is also helpful in sensing a stall condition, since the tone level and intensity of sounds incident to flight decrease as the airspeed decreases. The reduction of the noise made by the air flowing along the canopy as airspeed decreases is also quite noticeable, and when the stall is almost complete, vibration and its incident noises often increase greatly.
 - c. Kinesthesia, or the sensing of change in direction or speed of motion, is probably the most important and the best indicator to the trained and experienced pilot. If this sensitivity is properly developed, it will warn of a decrease in speed or the beginning of a settling or "mushing" of the airplane.
 - d. The feeling of control pressures is also very important. As speed is reduced, the resistance to pressures on the controls becomes progressively less. Aircraft response to control movements also decreases until a complete stall, when all controls can be moved with almost no resistance, and with little immediate effect on the airplane. The Stick shaker will normally occur 5-10 knots prior to the stall, with airframe buffet occurring almost immediately thereafter. The stick shaker may sometimes mask airframe buffet making it difficult to feel. In some circumstances, aircraft buffet may occur before the stick shaker activates.

Accomplish and/or review the **THREE Cs** before performing stall maneuvers. The **THREE Cs** may be accomplished in any order and are not required between individual maneuvers if flown in a series.

CONFIGURATION: Put the aircraft in the appropriate configuration.

CHECKLIST: Complete the Pre-Stalling, Spinning, and Aerobatic Checklist.

CLEAR AREA: Clear working area with visual scan, TCAS, and clearing turns as required.

A clearing turn (approximately 180°) utilizing 30-60° angle of bank; 45° angle of bank maximum in the landing configuration. Normally, turning stalls should be performed in the

same direction of the last clearing turn but can be adjusted as needed to remain within the working area boundaries. Recovery from all stall maneuvers must be accomplished above 6000 feet AGL.

Stalls will be preceded by the stick shaker or airframe buffet (whichever occurs first), at which point, recovery will be initiated. However, during some training maneuvers you will practice full stalls (nose pitches down) before initiating recovery. This is done, not to foster a complacent attitude towards stalls, but to build skill and confidence in the recovery procedures. Obviously, if a stall warning (i.e., stick shaker) is encountered at any time other than during stall practice, you will initiate recovery immediately.

3. **Procedures.** Refer to procedures in this chapter.
4. **Common Errors.**

Not recovering at the first indication of stall.

515. ENERGY MANAGEMENT

1. **Description.** Planning a sortie profile that allows maneuvers to be accomplished in an order that optimizes time and energy.
2. **General.** Energy level is defined by airspeed (kinetic energy) and altitude (potential energy) and is manipulated with power, drag, and G-loading. Plan maneuvers in an order that minimize the requirement for deliberate energy changes, and make use of the inherent energy gaining or losing properties of individual maneuvers.
 - a. **Altitude And Airspeed Exchange.** Potential energy (altitude) and kinetic energy (airspeed) can be traded. For example, 1,000 feet of altitude equals approximately 50 knots of airspeed with the canopy bow on the horizon and maximum power.
 - b. **Optimum Energy Level.** In a typical MOA, optimum energy level for aerobatic maneuvering is 180 to 200 KIAS at an altitude midway between the top and bottom area limits. Energy is sufficient for any aerobatic maneuver after an airspeed or altitude exchange to meet briefed entry parameters.
 - c. **Losing Energy.** Energy may be decreased with low power settings, increased drag (speed brake), or increased AOA (G-loading). A simple way to lose energy is to perform a constant airspeed descent until the desired energy level is reached.
 - d. **Gaining Energy.** Energy gain is enhanced with low AOA (avoid flight near zero-G) and high power. The best method to gain energy is a climb at 140 to 160 KIAS with MAX power.

- e. **Energy Planning.** Constant awareness of total energy state aides in correct maneuver selection and effective profile management, which allows a smooth flow between maneuvers with minimum delay.

516. SLOW FLIGHT (SCATSAFE) MANEUVER

1. **Description.** The slow flight maneuver is designed to develop your ability to fly the aircraft in a near-stalled condition.
2. **General.** This maneuver will be demonstrated by the instructor and then flown by the student. Every takeoff and landing you make requires you to operate the aircraft at low airspeed. During training, students are taught "flight at minimum controllable airspeed" so they may learn the effect that airspeed has on aircraft performance and controllability.
3. **Procedures.**
 - a. **CONFIGURATION:** At a safe altitude (complete maneuver above 6,000 feet AGL), slow the aircraft below 150 KIAS and configure with the landing gear down.
 - b. **CHECKLIST:** Perform the Before Landing Checklist and the Pre-Stalling, Spinning, and Aerobatic Checklist over the ICS.
 - c. **CLEAR AREA:** Clear working area with visual scan, TCAS, and clearing turns as required.
 - d. Lower landing (LDG) flaps. Continue reducing airspeed to approximately 80 KIAS (15 units AOA), while setting approximately 45% torque.

NOTE

The stick shaker may be on throughout the demo.

Demonstrate the following aircraft flight characteristics:

S - Straight and Level. During operation on the back side of the power curve, increased AOA results in increased drag and a stall if not carefully flown. Note the pitch attitude, torque, and rudder deflection required to maintain straight-and-level flight. This is the sight picture a pilot should see at rotation during takeoff or just prior to touchdown during landing.

C - Coordination Exercise. Conduct a series of left and right turns, using 15-20° angle of bank. Keep the ball centered using coordinated rudder. Approximately two inches of right rudder is required to maintain straight-and-level, coordinated flight. Right turns require approximately twice the rudder deflection to maintain coordination. Left turns require approximately one-half inch of right rudder to maintain coordination.

A - Adverse Yaw. Lack of coordinated rudder during a turn results in weaving or “S-ing” on final. Select two points, one directly in front of the aircraft and one approximately 20° to the right of the nose. Without applying rudder, initiate a rapid right turn with 20° bank. Note the initial tendency of the nose to yaw left. After approximately 20° of turn, roll out rapidly without using rudder. The nose continues past the selected roll out point then comes back. Next, initiate a right turn, using coordinated rudder. Notice that the nose immediately tracks in a coordinated manner. After 20° of turn, roll out using properly coordinated rudder and note that the nose stops on the selected rollout point.

T - Torque and Turns. The T-6B initially tends to pitch up, yaw, and roll left if positive control is not maintained during full power takeoffs and landings. To demonstrate this, quickly increase power to MAX from straight-and-level, coordinated slow-flight and release the controls. The nose tracks up, yaws, and rolls left, and approaches a stall. Recover from the buffet, prior to stall. Reestablish slow-flight and increase power to MAX again. This time, hold proper takeoff pitch and apply coordinated rudder to maintain a proper nose track. Positive control of the aircraft ensures safe takeoffs, touch-and-go landings, and go-arounds.

S - Steep Turns. High angles of bank at slow airspeeds increase stall speed and cause rapid turn rates. Slowly increase bank towards 60° while adding power and back pressure to maintain level flight. Look at a point on the ground and watch the wingtip appear to pivot around the selected point. The AOA quickly increases, progressing into a stall. Roll out of the bank to recover from the impending stall.

A - Abrupt Control Movement. Fixation on the aim point during landing can cause an abrupt flare. Late recognition of the rapidly approaching runway causes the pilot to abruptly raise the nose of the aircraft, causing an approach-to-stall condition, a hard landing, or both. The stick shaker activates, but there is no decrease in sink rate. To demonstrate this, abruptly apply back-stick pressure to 20° nose-high to simulate snatching the control stick in the flare. The AOA rapidly increases and the aircraft progresses towards a full stall. Release backpressure to recover. To avoid this condition on landing, view the total landing environment and apply controls in a smooth, positive manner.

F - Flap Retraction. Flap retraction prior to the recommended airspeeds causes the aircraft to lose lift and develop a sink rate. From straight-and-level coordinated slow-flight, raise the flaps from LDG to UP without pausing at the TO position. While retracting the flaps, increase the pitch attitude to maintain altitude. Initially airspeed increases (due to reduced drag as flaps begin to retract), but as flaps retract towards UP, the AOA increases and a stall results. Recover from the stall by selecting LDG flaps.

E - Effectiveness of Controls. Rapid control inputs, especially in the flare, often do not give the aircraft sufficient time to respond. Move the ailerons with small, rapid movements. Notice that even with aileron movement, there is little effect on heading or bank during slow-flight. In slow-flight, smooth, positive inputs are required to effectively control the aircraft as there is less airflow over the control surfaces at slow airspeeds.

4. Common Errors.

- a. Abrupt control movements.
- b. Failure to clear area during maneuver.
- c. Failure to maintain altitude.
- d. Failure to use adequate trim.

517. POWER-ON-STALLS

1. **Description.** Stall the aircraft in a power-on condition to demonstrate the proper recovery when power is available.

2. **General.** Proper recognition and recovery of an aerodynamic stall with minimum loss of altitude. Aircraft pitch and bank angle will be held constant until control effectiveness is lost, indicated by uncommanded nose drop or unplanned rolling motion. To recover, RELAX back-stick pressure to break the stall, and select MAX power. Simultaneously LEVEL the wings and center the BALL. The maneuver is complete when the aircraft has established a positive rate of climb. An entry speed of 150 KIAS results in about 1500-2000 feet altitude gain.

3. Procedures.

- a. **CONFIGURATION:** Establish the aircraft in the clean configuration. Complete maneuver above 6,000 feet AGL.
- b. **CHECKLIST:** Perform the Pre-Stalling, Spinning, and Aerobatic Checks.
- c. **CLEAR AREA:** Clear working area with visual scan, TCAS, and clearing turns as required.
- d. **Straight-Ahead Stall.** Adjust the PCL to 30-60% torque. Raise the nose to a pitch attitude between 15-40°.
- e. Maintain attitude using increasing back pressure. Keep the wings level with coordinated rudder and aileron. Initiate recovery when control effectiveness is lost. An uncommanded nose drop despite increased backpressure or an uncommanded rolling motion indicates loss of control effectiveness. Do not attempt to maintain pitch attitude or bank angle after control effectiveness is lost. Full back-stick may not occur before recovery is required. Emphasize observation of aircraft handling characteristics during recovery from the stall and not the exact point where the full stall is reached.

- f. **Recovery.** Simultaneously **RELAX** back-stick forces as necessary to break the stall, advance the PCL to **MAX**, use coordinated rudder and aileron to **LEVEL** the wings, and center the **BALL**. Avoid excessive or abrupt rudder movements during recovery phase. As AOA decreases and stall is broken, positive pressure is felt in the controls. At lower pitch attitudes (between 15 and 30°), the aircraft stalls at a higher airspeed and regains flying airspeed faster. At higher pitch attitudes (between 30 and 40°), the stall speed is slower and a greater pitch reduction is necessary to regain flying airspeed.
- g. Use maximum AOA to minimize altitude loss (14-17.9 units AOA). Avoid a secondary stall (indicated by upward nose track stopping despite increasing back pressure on the control stick). A secondary stall is an accelerated stall that occurs after a partial recovery from a preceding stall. It is caused by attempting to hasten a stall recovery when the aircraft has not regained sufficient flying speed. Recovery is complete when the aircraft is wings level with a positive rate of climb.
- h. **Turning Stall.** Setup is the same as the straight-ahead stall, except 20-30° of bank in either direction is added. Hold the bank angle with rudder and aileron pressure until control effectiveness is lost. Recovery is the same as for the straight-ahead stall. A precision entry is not as important as proper recognition and recovery from the stall.

4. Common Errors.

- a. Failure to maintain a constant pitch or bank attitude prior to loss of control effectiveness.
- b. Failure to recognize loss of control effectiveness (early/late initiation of recovery).
- c. Failure to recognize when the stall has been broken (early/late initiation of recovery to level flight).
- d. Failure to minimize altitude loss during recovery. Recovering with less than 14-17.9 units AOA.
- e. Entering a secondary stall during the recovery.

518. POWER-OFF STALL (ELP STALL)

1. **Description.** Stall the aircraft in a power-off condition to demonstrate the proper recovery when no power is available.
2. **General.** Power-off stalls are flown to practice recovery from potentially dangerous low airspeed conditions prior to high key and during the ELP. Power off stalls could occur, for example, during a dead engine glide to high key when the pilot gets distracted and fails to maintain proper flying speed. Speed may decrease for various reasons, including inattention, task saturation, and attempts to stretch the glide to regain profile.

Before starting this maneuver, ensure you have plenty of airspace below you, as you will lose at least 1500 feet during the recovery, and will probably lose another 1000-2000 while setting up your dead engine glide. Best glide speed in the clean configuration is approximately 125 KIAS with a sink rate of 1350 to 1500 feet per minute. Pay close attention to the nose attitude and flight characteristics of the airplane when flying the power-off, best glide speed. After the recovery, you will return to this attitude and airspeed to complete the maneuver.

3. Procedures.

- a. **CONFIGURATION:** Establish the aircraft in the clean configuration. Begin the maneuver at slow cruise (150 kts), or airspeed at the IP's discretion. Complete the maneuver above 6,000 feet AGL.
- b. **CHECKLIST:** Perform the Pre-Stalling, Spinning, and Aerobatic Checks.
- c. **CLEAR AREA:** Clear working area with visual scan, TCAS, and clearing turns as required..
- d. Roll wings level. If at or below 150 KIAS, reduce power to 4-6% torque and begin decelerating towards best glide speed, 125 KIAS. If above 150 KIAS, reduce power to 4-6% torque and zoom glide to capture best glide speed, 125 KIAS.
- e. As airspeed approaches 125 KIAS, lower nose to the 125-knot glide attitude (horizon bisecting windscreen). Crosscheck VSI for 1350 – 1500 feet per minute sink rate. Re-trim and stabilize.
- f. Simulate High Key and lower the landing gear; Re-trim for 120-knot glide and commence a 15-20° AOB turn to Low Key. Complete the Before Landing Checklist.
- g. Raise the nose to 5-10° nose high and allow airspeed to decay until the first indication of impending stall (airframe buffet or stick shaker).
- h. Maintain the turn or profile ground track and recover by lowering the pitch attitude to put the prop arc on the horizon (~8° nose low) until 120 KIAS is regained. Altitude loss is approximately 800 feet.

4. Common Errors.

- a. Failure to recognize an approach to stall indication.
- b. Lowering the nose too far, resulting in excessive loss of altitude.
- c. Failure to properly capture airspeed.

519. LANDING PATTERN (APPROACH TURN) STALL

1. **Description.** Proper recognition of and recovery from approach to stall conditions in the landing pattern. Training emphasis is on recognition of approach-to-stall indications and appropriate recovery procedures. However, much like power-on stalls, the smoother the entry, the cleaner the stall.
2. **General.** In the landing pattern, unrecoverable stall or sink rate situations can occur before indications become obvious. If a stall indication occurs in the landing pattern, disregard ground track, and recover as described below. If in the pattern, do not hesitate to eject if recovery appears unlikely. Landing pattern (Approach Turn) stalls may be practiced in either direction and in any flap configuration.
3. **Procedures.**

Landing Pattern (Approach Turn) Stall

- a. **CONFIGURATION:** Establish the aircraft in the appropriate downwind configuration (120 KIAS gear down, flaps as required).
- b. **CHECKLIST:** Perform the Pre-Stalling, Spinning, and Aerobatic Checklist and the Before Landing Checklist.
- c. **CLEAR AREA:** Clear working area with visual scan, TCAS, and clearing turns as required.
- d. Simulate the transition near the abeam position IAW Contact FTI landing pattern procedures. Power should be approximately 14/15/18% torque respectively, airspeed 120/115/110 KIAS, trimmed in a descending 30° AOB turn to simulate the approach turn to final.
- e. Once stabilized on airspeed 120/115/110 KIAS in the simulated approach turn, raise the nose to 5-10 degrees nose high, and then reduce power to idle. Adjust ailerons to maintain AOB between 20-45 degrees, and increase back stick pressure to hold the pitch attitude.
- f. At first indication of stall, stick shaker or airframe buffet, recover with minimal altitude loss.

Landing Attitude Stall

- a. **CONFIGURATION:** Establish a simulated final approach at 5 to 10 knots above final approach airspeed commensurate with flap setting.
- b. **CHECKLIST:** Perform the Pre-Stalling, Spinning, and Aerobatic Checklist and the Before Landing Checklist.

- c. **CLEAR AREA:** Clear working area with visual scan, TCAS, and clearing turns as required.
- d. Retard the PCL to idle and execute a simulated landing transition. Hold the landing attitude constant until an approach to stall indication occurs. Recover on approach to stall indication, which is activation of the stick shaker or aircraft buffet, whichever occurs first. Recovery is similar to the Landing Pattern (Approach Turn) Stall.

Recovery

For all Landing Pattern (Approach Turn) stalls, recover at approach to stall indication; either activation of the stick shaker or aircraft buffet, whichever occurs first. Do not enter a full stall! Use **RELAX, MAX, LEVEL, BALL** to recover.

- a. **RELAX.** Relax back-stick pressure slightly to decrease AOA and break the stall (do not dump the nose).
- b. **MAX.** Power to **MAX**.
- c. **LEVEL.** Level the wings to the horizon, and then establish a positive climbing attitude. Use 14-17.9 units AOA for maximum performance.
- d. **BALL.** Apply right rudder as necessary to center the balance ball.

Recovery is complete when the aircraft is wings level and safely climbing.

4. Common Errors.

- a. Failure to maintain angle of bank during the entry. The aircraft will have a tendency to continue rolling past 30° to 45° angle of bank. In addition, with increasing angle of bank, the nose will have a tendency to drop.
- b. Releasing instead of relaxing back-stick pressure, or applying forward stick pressure on recovery, thus resulting in a nose low attitude and excessive altitude loss.
- c. Not relaxing back-stick pressure enough, causing the aircraft to remain stalled.
- d. Cycling rudders in an attempt to keep the ball centered before flying speed is attained.
- e. Delay in raising the nose to the recovery attitude to stop the altitude loss.
- f. Failure to add sufficient power on recovery.

520. SLIP

1. **Description.** A slip is an out-of-balance flight condition used to increase the sink rate and lose excess altitude while maintaining a constant airspeed and a specific track over the ground.

2. **General.** A slip occurs when the aircraft slides sideways towards the center of the turn. It is caused by an insufficient amount of rudder in relation to the amount of aileron and the angle of bank used. If you roll into a turn without using coordinated rudder and aileron, or if you hold rudder against the turn after it has been established, the aircraft will slide sideways towards the center of the turn. A slip may also occur in straight-and-level flight if one wing is allowed to drag; that is, flying with one wing low, and holding the nose of the aircraft straight by the use of rudder pressure. In this case, the aircraft slips downward towards the earth's surface and loses altitude. In a full slip, the rate of descent may be in excess of 2000 feet per minute.

3. **Procedures.**

- a. Although the slip can be flown at any airspeed or configuration, it will normally be demonstrated and introduced at altitude simulating the slip to high key at 125 KIAS, clean configuration. Slips may also be demonstrated at 120 KIAS with gear down/flaps as required.

NOTE

Caution must be exercised, since stall speed is increased in this out-of-balance flight condition.

- b. To initiate a slip from wings level, lower one wing while applying opposite (top) rudder pressure. Select a reference point on the horizon and adjust rudder pressure and/or angle of bank to maintain the desired ground track. Full rudder deflection is not required during a slip. If full rudder deflection is used, remain below 150 KIAS. Use caution if electing to slip with gear down, especially low to the ground.
- c. To initiate a slip while in a turn, lower the inboard wing while increasing opposite (top) rudder pressure. It will be necessary to vary the angle of bank and rudder pressure to maintain the desired track over the ground.
- d. Monitor airspeed closely, adjust nose attitude as necessary to maintain 125 KIAS. Monitor the VSI and note increased rate of descent.

NOTE

The low-fuel warning light for the low-wing tank may illuminate regardless of fuel state.

- e. To recover from the slip, smoothly roll the wings towards level while reducing rudder pressure. Remember, the slip must be taken out with enough altitude remaining to slow the rate of descent and ensure positive control of the aircraft during the final moments of any maneuver in which it is used.

4. Common Errors.

- a. Improper application of rudder, resulting in a skid.
- b. Poor airspeed control. Remember, nose attitude still controls airspeed.
- c. Not varying angle of bank or rudder pressure to maintain desired track over ground.
- d. Rough entry and recovery control applications.

521. SPIN

1. **Description.** Two primary factors must be present for an aircraft to spin; stalled AOA and yaw (rotation about the vertical axis).
2. **General.** Spins are taught to increase your situational awareness and confidence in extreme unusual attitudes and out-of-control flight (OCF) conditions. Practice spins to the left and right. The spin entry is straightforward and procedural; the spin entry is not a finesse maneuver. It requires full back stick (ailerons neutral), fully deflected rudder, and idle power.

We practice spins for the same reason we practice stalls. Stalls and spins are not normal flight maneuvers, but they can occur during flight, and only through practice can they be recognized rapidly and recovered from instinctively and reflexively by making the mechanical flight control inputs necessary.

Spins are generally performed only for air shows and training, but in WWI spins were used to descend through a cloud layer safely. With no flight instruments, early aviators who tried to fly through the clouds could easily get vertigo and enter a spiral with rapidly increasing airspeed that (when exceeding V_{ne}) resulted in destruction of the plane and the aviator. A solution was to enter a spin, descend down through the clouds, and hope you had enough altitude and visibility after breaking out to recover safely. With technology and instrumentation, this maneuver is no longer needed to descend through a cloud layer.

An airplane's design is a compromise between stability and maneuverability. Modern civilian general aviation and transport planes are designed with stability in mind, and although not spin-proof, are usually difficult to spin. Very few modern trainers are certified for spins. Military fighter and attack aircraft, however, are designed for maneuverability and performance. These high performance planes have poor stall characteristics and can depart from controlled flight readily and violently during high G and high AOA maneuvering. A departure usually begins with a stall and can then involve a pitch-up, nose slice, pitch-roll coupling, pitch-yaw coupling or some other type of post-stall gyration, resulting in a spin/out-of-control situation. To successfully recover, the pilot has to immediately assess what is going on and put in the proper control inputs to affect recovery. If the aircraft will not recover, the pilot needs to recognize it in ample time to eject safely.

For these reasons, spin training is started early in a Student Naval Aviator's primary flight training. Spins are confidence builders for a student. They build confidence in his or her own ability to maintain orientation and reflexively apply proper recovery controls. They also build his or her confidence in the ability of the airplane to respond to specific flight control inputs and regain normal flight. Even in our relatively stable training plane, an incipient spin can develop with improper or heavy-handed flight control inputs during stall training or aerobatic maneuvers. A snap roll, such as you see in air shows, is simply a spin while flying horizontally (performed by abruptly pulling back-stick to stall the wing and kicking rudder in the direction of the desired roll). Instructors Under Training perform fully developed spins and progressive spins to more fully investigate the spin characteristics of the T-6B, because they will be doing a lot of intentional spins (and perhaps some unintentional ones!) during their tour in the training command.

A spin progresses through three phases: post-stall gyrations, incipient spin, and steady state spin. The aircraft progresses from one phase to the next as long as pro-spin controls are applied. Failure to promptly apply proper recovery procedures during the first stages eventually results in a steady state spin. It is important to understand the recovery method required in each phase.

NOTE

Spins shall be practiced in the clean configuration. In the event of an unintentional spin with gear and flaps down, they shall be retracted immediately to prevent possible damage by exceeding their speed limitations.

- a. **Post-stall Gyrations:** A post-stall gyration can usually be identified by uncommanded (and often rapid) aircraft motions about any axis, a feeling that the controls are no longer effective nor acting in the normal sense, stalled or near-stalled angle of attack, transient or erratic airspeed indications, and random turn needle deflection. In order to recover from post-stall gyrations, execute the *INADVERTENT DEPARTURE FROM CONTROLLED FLIGHT* Procedure.
- b. **Incipient Spin:** Incipient spins are the spin-like motion that occurs between a post-stall gyration and a fully developed spin. An incipient spin can be identified by an oscillatory spin-like motion, a fully deflected turn needle, a stalled angle of attack, and airspeed that is accelerating or decelerating toward the steady-state value. The incipient spin phase lasts approximately 2 turns. After completing the initial turn, the nose will pitch to approximately 60° below the horizon, with pitch attitude becoming oscillatory. In order to recover from the incipient spin, execute the *INADVERTENT DEPARTURE FROM CONTROLLED FLIGHT* Procedure.
- c. **Steady State Spin:** After completing approximately 3 turns, the spin will have entered a near steady-state condition. Spin rotation rates will stabilize to approximately 2 to 3 seconds per turn with altitude loss of 400 to 500 feet per turn. The angle of attack will be 18+ and airspeed will stabilize at 120 to 135 KIAS. The

turn needle will be fully deflected in the direction of the spin. When performing spins to the left, the pilot may notice some differences in pitch attitude and magnitude of pitch, roll, and yaw oscillations. Spins in either direction may exhibit roll and yaw oscillations after 3 turns with neutral ailerons. Recover from a steady state spin by using NATOPS erect spin recovery procedures.

NOTE

All spin maneuvers shall be done with a clearly defined horizon, clear of clouds. Spin maneuvers may be performed over an undercast cloud layer that does not exceed 4,500 ft. AGL.

NOTE

Ailerons have pronounced effect on spin characteristics. With ailerons held in the direction of spin rotation, roll and yaw become noticeably oscillatory. With ailerons held full opposite to direction of spin rotation, roll and yaw oscillations are damped out and the spin appears to reach steady-state in all axes. You will keep ailerons neutral for all spin training in the T-6B.

3. Procedures

a. Intentional Spin Entry

- i. **CONFIGURATION:** Establish and trim the aircraft in slow cruise configuration (150 KIAS). Trim will remain constant throughout the maneuver. Start the maneuver at an altitude so that the spin itself is entered below 22,000 feet MSL, and recovered before 10,000 feet MSL. Minimum entry altitude is 13,500 feet MSL.
- ii. **CHECKLIST:** Perform the Pre-Stalling, Spinning, and Aerobatic Checklist.
- iii. **CLEAR AREA:** Sufficiently clear the working area. Since considerable altitude will be lost in the spin, be sure that the area below is clear of other aircraft or clouds. TCAS "Below" mode may be used to aid clearing area below.
- iv. Roll out of the clearing turn, reducing the power setting to idle.
- v. Check the wings level and smoothly raise the nose (on the PFD) to 30° above the horizon. When the gear warning horn activates, SNA shall acknowledge the warning horn, however the IP shall silence the horn prior to spin entry.
- vi. At the stick shaker, lead the stall with a slight amount of rudder in the desired direction of spin. Spins will be conducted in same direction as the last half of the clearing turn.

- vii. When the aircraft stalls (recognized by the nose pitching down), smoothly apply full rudder in the direction of spin and full back-stick. Do not use aileron in the entry or during the spin. Call out altitude, AOA, airspeed, turn needle deflection/direction.

b. **Incipient Spin Recovery**

Upon recognition of an incipient spin by stalled AOA, airspeed that is accelerating or decelerating toward the steady-state value, and turn needle fully deflected in direction of spin, initiate the ***INADVERTENT DEPARTURE FROM CONTROLLED FLIGHT*** Procedure, in accordance with the T-6B NATOPS Flight Manual. The incipient spin phase lasts approximately 2 turns.

PCL – IDLE

CONTROLS – NEUTRAL

ALTITUDE – CHECK

RECOVER FROM UNUSUAL ATTITUDE

NOTE

When positioning the controls to neutral, it is not uncommon to mistakenly position the elevator slightly aft of neutral. If the aircraft is not recovering as expected, slowly feed in forward stick until the neutral elevator position is reached and the aircraft recovers.

NOTE

If spin develops into steady state spin, then the IP should give consideration to altitude loss and working area restrictions and recover by using NATOPS erect spin recovery procedures.

c. **Steady-State Spin Recovery**

- i. At spin entry, scan inside the cockpit to verify sufficient altitude for recovery, stalled AOA, airspeed stabilized 120 to 135 KIAS and turn needle fully deflected in direction of spin, respectively.
- ii. After verifying stabilized spin indications, initiate the recovery from the spin by first applying full rudder opposite to the direction of rotation. Follow immediately with smooth, positive forward stick to a position forward of neutral. Do not use ailerons! A common error is unintentionally placing the stick in the neutral or slightly aft of neutral position.

- iii. Hold the controls in position until the rotation stops, and then recover with a minimum of loss of altitude.
 - (a). Neutralize the controls
 - (b). Level the wings by referencing the horizon.
 - (c). Commence a smooth pullout. Use sufficient G during pullout to maintain lower working area boundaries. Avoid secondary stalls and do not exceed G limitations.
 - iv. Continue the pullout until the nose is positioned to the level flight attitude. Recover with a minimum loss of altitude. Emphasis is on smooth control inputs.
 - v. Check and report oil pressure (minimum of 90 psi).
 - vi. Add power as required.
4. **Common Errors.**
- a. Not reducing power to idle after rolling wings level from the clearing turn.
 - b. Becoming disoriented by looking outside and delaying initiation of recovery.
 - c. Not neutralizing the controls as the rotation stops.
 - d. Commencing the pullout too rapidly and/or too early, resulting in a secondary stall.
 - e. Insufficient G pull on recovery, resulting in inadvertently exiting lower working area boundaries.
 - f. Not checking the oil pressure, late in adding power when level, and not reporting oil pressure to the instructor.
 - g. Inadvertently placing the stick aft of neutral, delaying or preventing recovery.

CHAPTER SIX LANDING PROCEDURES

600. INTRODUCTION

This chapter discusses the procedures and operations required for the T-6B to enter, land, and depart the landing pattern.

601. LANDING PATTERN

The landing pattern is a geometric racetrack-shaped course flown so that an approach and landing may be executed in a systematic sequence. The landing line, the upwind leg, and the parallel downwind leg form the sides of the racetrack pattern. These lines are joined together by the crosswind turn and by the approach turn at the downwind end of the pattern. For purposes of clarity in this instruction, the landing pattern will be subdivided into three parts: the pattern, approach, and landing.

602. LANDING PATTERN TERMINOLOGY

1. Visual Wing References

- a. Wingtip distance: Wingtip bisecting the intended point.
- b. $\frac{3}{4}$ Wingtip distance: Where the orange meets the white on the wing leading edge.
- c. $\frac{2}{3}$ Wingtip distance: Fuel cap.
- d. $\frac{1}{4}$ Wingtip distance: Where the canopy rail visually bisects the wing.

2. **Initial Point.** A point over the ground at the appropriate distance from the runway as specified by the local SOP. At this point the aircraft shall be at the altitude and airspeed specified by the local SOP.

3. **Break.** An overhead transition from cruise to the downwind configuration. The break is basically a LSC conducted while in a turn.

4. **Break Altitude.** Consult local SOP or Course Rules.

5. **Pattern Interval.** Determine the number of aircraft and visually acquire each aircraft to determine the proper interval. You have "interval" when any of the following conditions occur:

- a. The aircraft ahead of you is abeam or behind your wingtip AND has completed at least 90° of turn.
- b. The aircraft ahead has departed in accordance with local SOP or course rules.

- c. At a tower-controlled field, the above conditions are met, AND you are cleared by the controller.
- d. If the preceding aircraft is a full stop or you are a break aircraft, the proper interval for breaking behind another T-6 is 45° behind your wingtip. Other break intervals are specified by local SOP.

NOTE

If following an aircraft conducting AOA approaches, your instructor will judge the proper interval for the crosswind turn.

6. **Upwind.** The extended runway centerline past the departure end.
7. **Downwind.** That portion of the racetrack pattern offset from the runway in the opposite direction of landing.
8. **Crosswind Turn.** The turn between upwind and downwind.
9. **Abeam.** The position in the racetrack pattern opposite the intended point of landing at pattern altitude.
10. **180° Position.** The position in the racetrack pattern opposite the intended rollout point.
11. **90° Position.** The bisector between the 180 and intended rollout point. The aircraft should be 450 feet AGL (or ½ the pattern altitude in feet AGL) and perpendicular to the runway. Airspeed is dependent on the type of approach. (Civilian equivalent: Base Leg)
12. **Final.** The extended centerline of the runway with 1200-1500 feet of straightaway from the rollout point to the runway threshold at an altitude between 100-150 feet AGL. Airspeed is dependent on the type of approach.
13. **Intended Point of Landing.** This is the point on the runway where you intend for the aircraft to touch down and allows you to stop the aircraft within the remaining length of the runway. Intended Point of Landing is normally 500 feet past the runway threshold, or as defined by local SOP. The Intended Point of landing may be changed as needed to account for unusual runway conditions such as a raised barrier or a displaced threshold.
14. **Touchdown Zone.** This is an area from the intended point of landing extending to 500 feet beyond that point. Strive to make all landings in the Touchdown Zone. Safe landings may be made outside the touchdown zone, either prior to the Intended Point of Landing or past the Touchdown Zone. If unable to execute a safe landing (within the first 1/3 of the runway or as determined by local SOP), WAVE OFF.
15. **Aimpoint.** The aimpoint is a reference point at the approach end of the runway (usually the runway threshold) used to fly the aircraft down final approach. It is the point at the end of

the aircraft's glidepath where the transition to landing should commence. It is not the intended point of landing. The aimpoint should remain fixed in the windscreen on final approach when the aircraft is on speed and altitude. Stable airspeed, proper glide path, and a fixed aimpoint provide the consistency required for successful landing.

16. **The Extended Runway Centerline.** The extended runway centerline is the line over which the aircraft should track while on the final approach to landing.

17. **Departure Interval.** You are number one for departure when past the departure end of the runway (or as defined by local SOP), flaps up, and the aircraft upwind has either initiated the crosswind turn or raised the landing gear to depart.

NOTE

In order to depart, you do not have to be number one with interval, but you must be number one upwind. There is a difference!

603. OUTLYING FIELD ENTRY

1. **Description.** The outlying field entry (OFE) is a series of uniform procedures by which aircraft enter the landing pattern.

2. **General.** Since numerous (5-10) aircraft may be using the same outlying field (OLF) simultaneously, it is absolutely necessary that each aircraft conform to the same systematic pattern and standard operating procedures for safety and efficiency.

3. **Procedures.**

- a. Determine the duty runway.
- b. Fly to establish the aircraft at the appropriate initial point. At this point the aircraft shall be:
 - i. on extended runway centerline and on runway heading.
 - ii. wings level.
 - iii. at break altitude (see local SOP).
 - iv. airspeed in accordance with local SOP.
- c. When at the initial point, make the appropriate radio call.
- d. Fly from the initial point towards the runway maintaining altitude and airspeed, visually locate pattern traffic, and obtain wind information

4. Common Errors.

- a. Not selecting the appropriate outlying field channel.
- b. Not positioning the aircraft for the correct runway.
- c. Incorrect voice report.
- d. Not properly established at initial point.
- e. Not establishing the proper break interval.
- f. Continuing inbound for the break without two-way communications with the RDO.

604. THE BREAK

1. **Description.** The break is a procedure to transition the aircraft from normal cruise configuration to the landing configuration and position the aircraft on the downwind leg (Figure 6-1).
2. **General.** The following procedures will prepare the aircraft for landing at a field.
3. **Procedures.**
 - a. Establish the proper interval in accordance with local course rules.
 - b. With interval, execute the break in accordance with local SOP.
 - c. Clear in the direction of turn, then roll into a 45°-60° AOB turn, reduce power (idle to ~10% torque), extend speed brake as required and maintain altitude. AOB and back-stick pressure will vary with wind conditions. Trim for deceleration.
 - d. Verbally confirm airspeed below 150 KIAS on the ICS. Lower the landing gear after the IP has acknowledged the airspeed call. "Below 150, Gear," is the challenge, and "Clear" is the response.
 - e. Halfway through the break turn, adjust the angle of bank to establish a $\frac{3}{4}$ - 1 wingtip distance on downwind.
 - f. Slow to 120 KIAS, maintaining break altitude, trimming right rudder and up elevator for deceleration.
 - g. Approaching 130 KIAS, retract the speed brake if extended, lower the nose and descend at 120 KIAS to pattern altitude (as directed by local SOP). No sooner than wings level on downwind, lower the flaps to the desired setting.

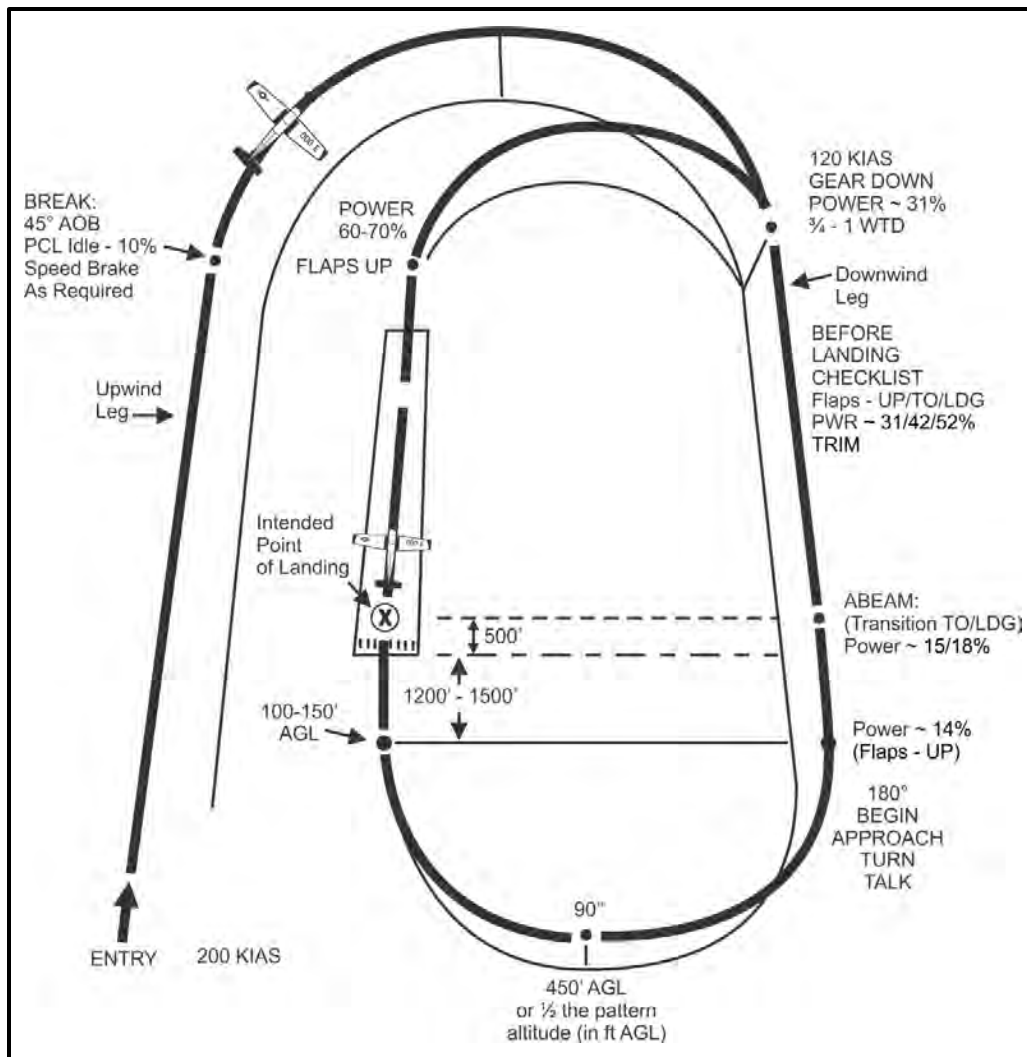

Figure 6-1 Landing Pattern

- h. Level off at pattern altitude using the P.A.T. principle:

Power. Approximately 31/42/52% torque for NF/TF/LF setting.

Attitude. Stop the descent by initially setting a slightly nose-up attitude immediately followed by the 120 KIAS level flight attitude.

Trim. Re-trim.

- i. Once established on downwind with the flaps at the desired setting, conduct the Before Landing Checklist.

4. Common Errors.

- a. Not establishing proper interval.

- b. Poor attitude/altitude control in turn.
- c. Not trimming right/up for deceleration.
- d. Not maintaining break altitude until reaching 120 KIAS.
- e. Descending below pattern altitude once established on downwind.

605. LANDING PATTERN

1. **Description.** N/A

2. **General.** The pattern is the portion that commences with the break, the takeoff following a touch-and-go or wave-off, and ends at the commencement of the approach turn (Figure 6–1). The following will be observed in the pattern:

- a. 30° AOB is desired with 45° AOB as the maximum. If a turn of greater than 45° AOB is required; wave-off.
- b. 120 KIAS with gear down and flaps up during upwind and crosswind. Configure and complete the Before Landing Checklist once established on downwind. Trim.
- c. Crosswind should not normally be initiated until past the departure end of the runway with interval. Comply with local SOP.

606. APPROACH

1. **Description.** Make a descending 180° balanced turn to final in the No-flap, TO-flap, or LDG-flap configuration.

2. **General.** The approach is the portion that commences at the 180° position and ends with a full stop landing, touch-and-go, or wave-off. This type of approach develops the student's judgment and ability to control airspeed with nose attitude and rate of descent with power, while tracking a prescribed pattern over the ground under varying wind conditions. It develops consistency in landing the aircraft on or near the intended point of landing.

NOTE

Pattern interval will be established in the break or crosswind turn and will *not* be corrected by variance of the approach from the 180 to final. If proper interval cannot be maintained: **Wave off.**

- a. **Downwind.** The downwind leg is flown at pattern altitude, at $\frac{3}{4}$ - 1 wingtip distance (WTD) as required from the runway centerline at 120 KIAS. WTD utilized on downwind should allow for a ~30° AOB turn to final, accounting for winds and flap setting. Once established on downwind, lower the flaps as

required and execute the Before Landing Checklist. Add power as required to maintain 120 KIAS: No Flap ~ 31%, TO-flap ~ 42%, LDG- flap ~52%. Torque settings utilized will vary based on aircraft weight. As power is added, right rudder trim is required.

NOTE

In perfectly calm wind conditions, the downwind heading (reciprocal of runway heading) will maintain the proper spacing once a $\frac{3}{4}$ - 1 WTD has been established. However, this is not true when a crosswind exists. If there is a crosswind, the aircraft will have to be angled (crabbed) sufficiently into the wind to prevent drifting into or away from the runway. It is not uncommon to have to alter the downwind heading as much as 15° to maintain proper spacing abeam the runway.

- b. **Transition.** The actual position where the transition is initiated and torque settings utilized will vary based on conditions such as winds, weight and aircraft configuration in order to maintain airspeed. Initiate the transition no sooner than when abeam the intended point of landing, but early enough to arrive at the 180 position with the proper approach speed and the aircraft in a trimmed condition. Under calm wind conditions, the transition occurs approximately 4-7 seconds past the intended point of landing. Begin the transition by reducing power smoothly towards the desired power setting, setting the appropriate attitude, and trim left rudder and up elevator. Torque settings are approximately 14/15/18% for No-flap/TO-flap/LDG- flap (NF/TF/LF) landings respectively. ***A no-flap landing will not require a transition (power reduction) until the 180.***
- c. **The 180.** This is the position on the downwind leg from which the approach turn is commenced, and is the point opposite the intended rollout point. Upon reaching the 180, commence the approach TURN by simultaneously lowering the nose to the 120/115/110 KIAS (NF/TF/LF) approach attitude and smoothly turning toward the 90° position. Due to the transition power reduction, lowering the nose is necessary to capture the desired airspeed.

NOTE

At no time during the approach turn should you slow below onspeed AOA (amber donut AOA indication). If at any time you slow below onspeed AOA (green chevron AOA indication), trim nose down and add power to increase airspeed. It is not uncommon to require greater than 120 KIAS in the approach turn in the NF configuration in order to prevent slowing below onspeed AOA.

The pitch attitude of the aircraft in a LDG-flap approach is lower than in a no-flap approach. Initially a good sight-picture is 2/3 ground, 1/3 sky for a LDG-flap and 1/2 sky, 1/2 ground for a no-flap landing. The no-flap approach will typically

require a slightly steeper angle of bank and further power reduction to achieve the proper racetrack pattern checkpoints. Maintain balanced flight. Re-trim as necessary. Do not skid or slip the aircraft through the turn. One of the most important concepts to understand is that every approach must be started from the same relative position.

The runway is a landmark. Pilots are encouraged to look at it frequently. Also, objects on the ground should be used as pattern checkpoints so as to fly the same consistent path over the ground regardless of wind. When ground checkpoints around the pattern are available, they can be used in getting to the final checkpoint, the runway. The more experience you have, the more you will look out the canopy to compensate for abnormal conditions.

After starting the approach turn:

- i. TALK, give appropriate 180 call in accordance with SOP.
- ii. Commence a comprehensive scan of instruments and external references.

Instruments:

Airspeed - Adjust attitude and trim to obtain proper airspeed.

VSI - Adjust power to ensure approximately 800 fpm descent.

AOB - Approximately 30 degrees (do not exceed 45 degrees).

Altimeter - Ensure aircraft will arrive at the 90 at 450' AGL.

External:

Visualize an oval track over the ground that arrives on extended centerline 1,200-1,500 feet from the runway threshold, and fly that track. When available, utilize landmarks for the 90.

When external cues are limited (at night, over water or low visibility), you will need to increase the instrument scan.

- d. **The 90.** The 90° position is a fixed position at the midpoint of the approach turn at which the aircraft's heading is 90° from the runway heading. The aircraft should pass through this position at 120/115/110 KIAS (NF/TF/LF) and 450 feet AGL or ½ the pattern altitude in feet AGL. (Figure 6-2).

Continue to fly the aircraft from the 90° position and anticipate a rate of turn which will enable you to intercept the extended runway centerline with 1200-1500 feet of straightaway from the threshold, 100-150 feet AGL, and wings level.

After the 90 position, begin to decelerate to the final approach speed of 110/105/100 KIAS (NF/TF/LF). If on profile at the 90° position, a slight power reduction will be required in order to initiate deceleration once wings level on final. Trim left rudder and nose up. Check and report on the ICS IAW local SOP.

The need for corrections in the approach must be recognized as soon as possible and the actual corrections must be small to avoid over correction. Although power controls the rate of descent and the nose attitude controls the airspeed, it must be remembered that the combination of attitude (nose and wing) and power work together to produce aircraft performance. Any change in attitude (nose or wing) to maintain the proper glidepath will require a corresponding change in power. No written outline can effectively state all possible errors in a landing approach. The procedures that are utilized to correct for deviations from the desired altitude/airspeed are those learned on your first flight. Remember, the combination of attitude and power work together to produce aircraft performance.

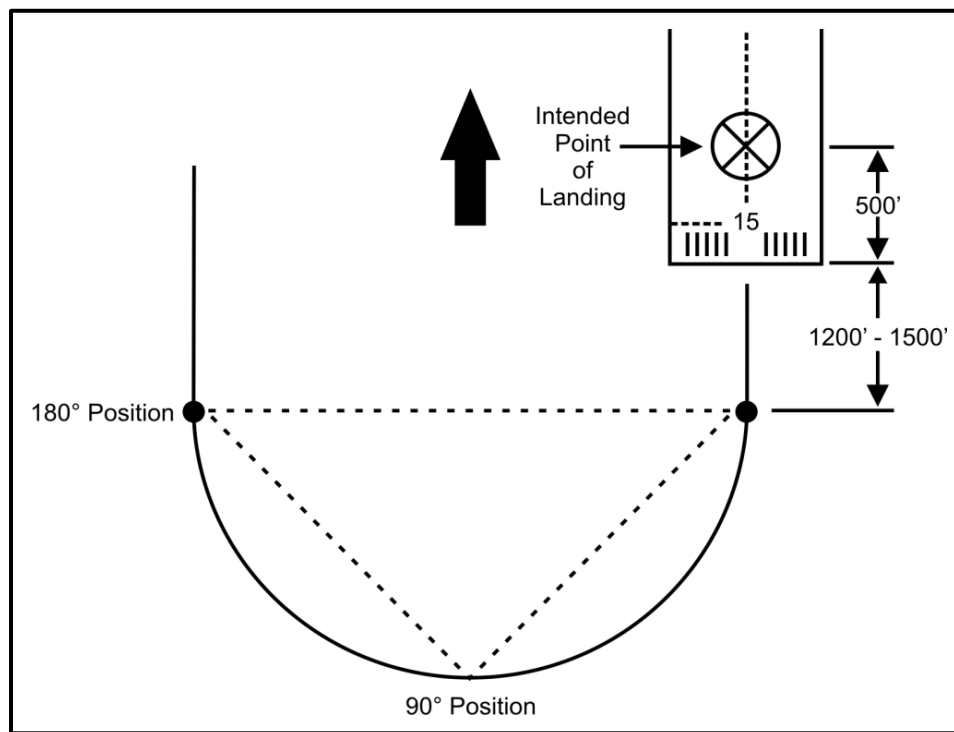

Figure 6-2 90° Position

- e. **The "final" (or "groove")** is that final portion of the landing approach, beginning at a point 1200-1500 feet from the runway threshold at an altitude of 100-150 feet AGL where the aircraft is first aligned, wings-level and ends with the landing transition. The length of the straightaway should provide 8-10 seconds prior to landing (Figure 6-3).

The entire pattern to this point is designed to position the aircraft to intercept the glideslope in the "groove." The power and/or attitude must be adjusted and readjusted in order to achieve and maintain a constant rate of descent, and also to stabilize the glideslope "picture." Power required will vary with wind conditions.

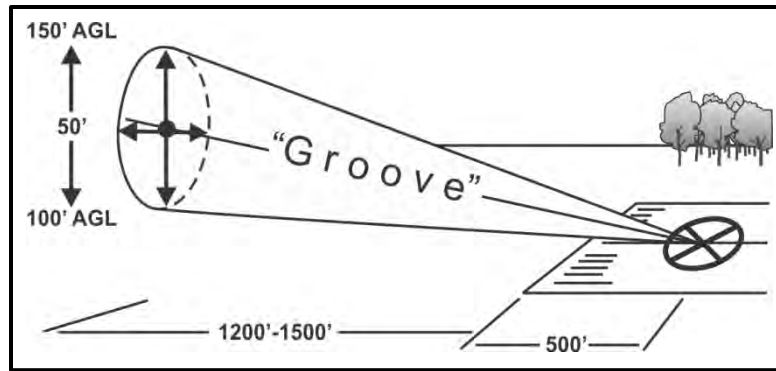

Figure 6-3 The "Groove"

In order to fly a good approach, it is important to solve lineup problems early. After rolling out on straightaway, if the centerline is not between your legs, correct immediately and positively. Implement any required crosswind corrections to maintain centerline using the wing-low, top rudder method described in the crosswind section of this chapter. Following this correction, continue to scan lineup, making small corrections as necessary. Do not ease yourself to centerline, or a counter-correction will have to be made close to the touchdown point of the runway.

Rolling wings level while aligning the airplane with the runway centerline, the nose attitude should be maintained and a reduction in power (approximately 2-5% torque depending on configuration and wind conditions) will be necessary to compensate for the increase in lift. Slight adjustments in pitch, changes of nose attitude, and power may be necessary to maintain the descent attitude while gradually decelerating. When the nose attitude and airspeed have been stabilized, the airplane should be re-trimmed to relieve the pressures on the controls. Do not slow below 110/105/100 KIAS or on speed AOA until commencing the landing transition. Crosscheck airspeed with AOA. At higher aircraft weights, higher airspeeds may be required to maintain no slower than on speed (amber donut) AOA indication.

To maintain a constant glideslope, it is necessary to maintain a fairly constant airspeed and rate of descent. Given that the aircraft has a constant attitude for each airspeed, power, and configuration combination, we will be able to reference the nose position to glideslope and aimpoint. Mentally superimpose our symbolic aircraft on the glideslope and you should see that by maintaining airspeed (meticulously) and a constant sight picture of the aimpoint, you will maintain a constant rate of descent to land in a predictable area of the runway.

If your airspeed is "locked on" and your aimpoint appears to be rising in the HUD/windscreen, your aircraft is falling below the desired glideslope. Add power, raise the nose to maintain airspeed and fly back up to the glideslope. Anticipate a slight power reduction when back on glideslope and lower the nose to the approach attitude to reestablish the rate of descent.

Conversely, if your aimpoint disappears beneath the nose and airspeed is "locked on," you have flown above the glideslope and need to reduce power. Lower the nose, thereby increasing the rate of descent while maintaining airspeed. Anticipate a slight power addition once reestablished on glideslope and readjust the nose attitude to "set" the desired rate of descent (Figure 6-4).



Figure 6-4 Aimpoint

Balanced flight must be maintained throughout the approach. An unbalanced flight condition increases the stalling speed, gives an erroneous impression of the flight path of the aircraft, and may cause difficulty during the subsequent landing transition, touchdown, and/or landing rollout. Fly the aircraft smoothly; avoid sudden or erratic control movements. Remember, good basic airwork and proper trim are mandatory in the approach. The proper amount of rudder and up elevator trim will enable the aircraft to "fly itself" with very little control pressure. The key to a good landing is a good approach.

- f. There are five general areas to consider in flying a good approach.
 - i. **SCAN.** A rapid integrated scan pattern is a necessity. The scan includes the landing environment, as well as scan of aircraft instruments for an accurate appraisal of the pilot's present situation. Anticipation of trends and early corrections can then be made.
 - ii. **FUNNEL EFFECT.** Because of the cone shape of the straightaway/groove, large corrections may be made while far out, and small corrections in close.

- iii. **COUNTER-CORRECTION.** For every correction that is made, there will be a counter-correction necessary to achieve stability. The overall goal is to achieve stability of attitude and rate of descent, and cross the runway at a precise altitude on the centerline of the landing area. Stability of the above factors must not be construed to mean that power and controls are necessarily stable. Smoothness comes from recognizing errors early through a rapid scan, and being able to make a small correction before the aircraft deviates outside of the cone.
- iv. **AIRSPEED AND AOA.** Cross check airspeed with AOA. At higher aircraft weights, higher airspeed may be required to prevent slowing below on-speed AOA (amber donut) indication. Above 700 to 800 pounds of fuel, approximately 3-5 knots above the 120/115/110 approach turn airspeeds may be required. Be alert and halt excessive sink rates with coordinated power and trim inputs. Heavy aircraft are less responsive to pitch and power changes, and develop sink rates quicker than light aircraft.
- v. **Gusty Wind Conditions.** Increase the final approach airspeed by one-half the gust factor, up to a 10 knot increase. Gusty winds do not affect final turn airspeeds. Realize that the aircraft may float farther than normal in the flare prior to touchdown due to the extra airspeed.

The glideslope (altitude) is controlled primarily with power, and the attitude/airspeed primarily with the stick, but it cannot be overemphasized that there must be a coordinated use of both in any correction. In analyzing a situation, there are two basic elements to be considered: speed (either fast or slow) and altitude (either high or low). There are many possible combinations of these elements, which will compound the error analysis and correction. The following is a list of the most common deviations and corrections to ensure the "perfect approach," Figure 6-5.

- (a). **HIGH** - To correct a high situation, reduce power slightly and lower the nose to maintain airspeed with nose attitude. Power should be reduced, because it is probably why the aircraft got high in the first place. Do not reduce power excessively. **DO NOT** attempt to correct for being high once over the runway. Attempting to do so will result in a hard landing, which could cause structural damage to the aircraft.
- (b). **LOW** - To correct a low situation, add power and raise the nose to maintain airspeed. The nose attitude correction is vital. Attitude must be adjusted if the correction is to be timely. Adding power alone will merely accelerate the aircraft.
- (c). **FAST** - To correct, reduce power slightly while simultaneously applying slight backpressure on the stick. Readjust power when the aircraft decelerates to the proper airspeed.

- (d). SLOW - Most importantly **NEVER** accept being Slow. To correct, add power and apply forward pressure to the stick to increase airspeed. Reduce power and readjust nose attitude when the aircraft reaches the proper airspeed.

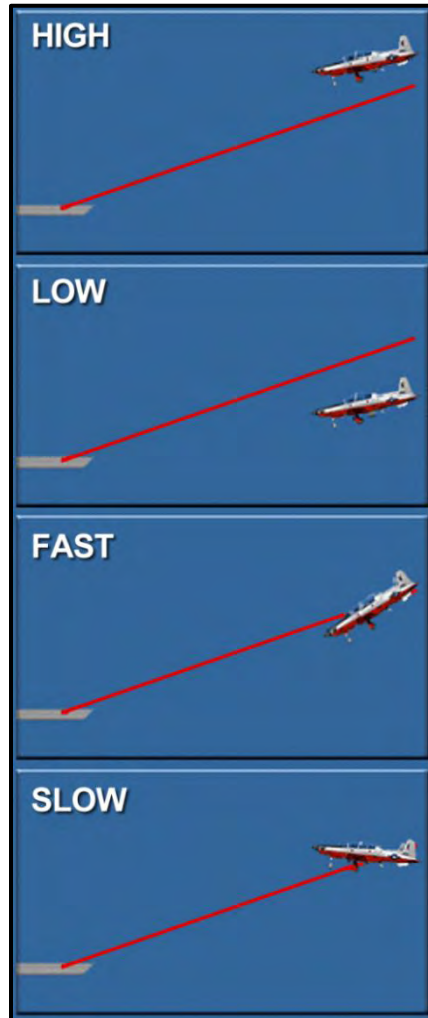

Figure 6-5 Glideslope Corrections

3. **Procedures.**

a. **Downwind leg**

- i. Once established on downwind, lower the flaps as required and perform the Before Landing Checklist. Report the Before Landing Checklist complete over the ICS.
- ii. Maintain proper downwind, parallel to the runway at $\frac{3}{4}$ - 1 wingtip distance, pattern altitude, and 120 KIAS, using approximately 31% torque for NF, ~42% T/O Flap, ~52% LDG Flap. TRIM.

- b. No sooner than the abeam position, **TRANSITION**.
Reduce power as required – approximately 15/18% (TF/LF) respectively.
TRIM left rudder for the power reduction and nose up for deceleration.
- c. **180° Position**
- i. Opposite the intended rollout position, (if executing NF landing reduce power to approximately 14%) simultaneously lower the nose approximately 2-3 degrees to the NF/TF/LF approach attitude and capture 120/115/110 KIAS respectively.
 - ii. **TURN** towards the 90° position using approximately 30° AOB.
 - iii. **TALK**: Make appropriate radio transmission.
 - iv. Make necessary corrections throughout the approach using power to control rate of descent and nose attitude to control airspeed and AOA.
 - v. Re-trim the aircraft throughout the approach.
 - vi. Vary AOB and power as necessary to arrive at a proper 90° position; 120/115/110 KIAS, 450 feet AGL or ½ the pattern altitude in feet AGL, perpendicular to the runway.
 - vii. Intercept the extended centerline with 110/105/100 KIAS, 1200-1500 feet of straight away from the threshold, and 100-150 feet AGL, wings level.
- d. **Final**
- i. Maintain pitch attitude while making a slight power reduction. Aimpoint should be about 1/2 way up the windscreen.
 - ii. Maintain aimpoint (control stick) and glidepath (power).
 - iii. Gradually decelerate using a very slight power reduction. Trim nose up slightly.
 - iv. Maintain runway extended centerline using wing low and top rudder.
 - v. Scan windsock to determine wind direction and velocity.
 - vi. Visually check and verbally confirm gear down IAW local SOP.
 - vii. Do not slow below final airspeed until commencing the landing transition.

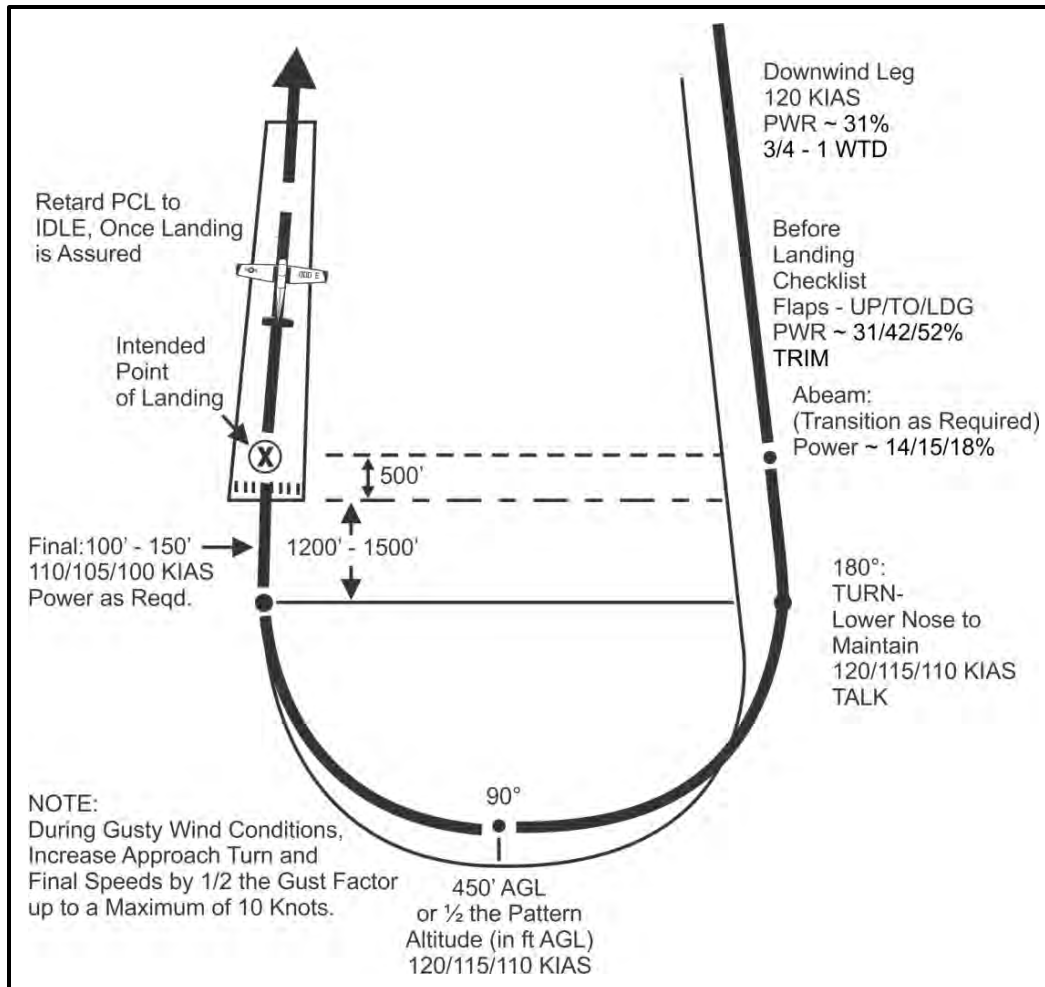

Figure 6-6 Landing Pattern From Downwind Leg to Landing

4. Common Errors.

- a. Not flying all checkpoints.
- b. Not maintaining the appropriate airspeed and altitude profile at the 90° and on final.
- c. Spotting the deck.
- d. Not checking RDO waveoff lights.

607. LANDINGS

1. **Description.** Land smoothly on the main-mounts at the intended point of landing on runway centerline.

2. **General.** Landing is divided into three phases: 1) Landing Transition, 2) Flare and Touchdown, and 3) Landing Roll. Each of these phases serves as a transition from the previous phase to the next. The landing transition serves as the transition from final to the flare; the descent rate on final is drastically reduced as the flight path becomes near horizontal in the flare. The flare is used to reduce energy in the transition from final to landing airspeed. The landing roll serves as the transition from landing to taxi. Airspeed is reduced straight-ahead on the runway until at safe taxi speed.

Landing Transition. Start power reduction and reduce descent rate. Power reduction reduces energy and helps prevent level-off as aimpoint is shifted. On final the aimpoint was held in a constant position on the windscreen. Approaching the threshold, (for a 150' wide runway when the width of the runway fills the windscreen, or approximately 10-20 feet AGL) descent rate is reduced by shifting the aim point progressively further down the runway. Using smooth aft elevator, shift the nose of the aircraft, and thus the aimpoint, toward the middle of the runway and then towards the far end of the runway. Shift your eyes at the same time, preventing you from spotting the deck (making a hard landing) and this will also help you see minor deviations in lineup and drift. A common error is not shifting the aimpoint resulting in an abrupt flare, flat landing or worse, touching down with a nose-low attitude. As descent rate and airspeed decrease, power is slowly reduced (towards idle in the flare).

Flare and Touchdown. In the flare, back-stick pressure is slowly increased until the proper landing attitude is reached as power is reduced and airspeed decreases. Your eyes should remain at the far end of the runway, using your peripheral cues and judging the descent rate of the plane as you modulate the power and elevator control inputs. The landing attitude is the same as the take-off and slow-flight attitude. As descent rate and airspeed decrease, the aircraft gently settles onto the runway. Ensure PCL is idle at touchdown. The aircraft may yaw to the right with power reduction, utilize left rudder to maintain alignment with the runway.

The aircraft will be in a slight descent or level flight depending on altitude, airspeed, power setting, and rate of deceleration. Use caution to avoid excess back-stick which could lead to a climb in the flare. As the nose rises, forward visibility is reduced and peripheral vision becomes the key factor in height and drift assessment. Touchdown is simply an end to the flare and should occur as landing speed is attained. (Roughly 7 KIAS below airspeed on final).

Flare at a rate proportional to the rate of descent. For example, higher descent rates require faster application of back-stick to attain normal descent rate prior to touchdown and prevent a firm landing. Similarly, a lower than normal descent rate requires slower control stick movement to prevent a high flare.

Maintain crosswind controls (wing-low) throughout the flare. As the airspeed decreases towards landing speed, use additional aileron and rudder deflection to maintain runway alignment. Crosswind controls increase drag, rate of deceleration, and stall speed.

In the flare, power can compensate for errors in judgment. Faster or slower power reductions can compensate for errors made in the landing transition and early flare. Apply power and go-around any time the controls feel mushy, the aircraft experiences an approach-to-stall indication, or if an excessively long touchdown will occur.

Crosswind controls must be held through touchdown and landing roll to prevent the upwind wing from rising and the aircraft from skipping. With significant crosswinds, expect the upwind main gear to touch down before the downwind main gear.

If power is used during the flare, retard the PCL to idle at touchdown.

After touchdown on a full-stop landing, slightly relax back-stick pressure and allow the nose gear to settle onto the runway. Avoid banging the nose gear.

Ensure your feet are not on the brakes when the aircraft touches down.

Landing Roll. With the nose gear on the runway and below 80 KIAS, smoothly apply brakes and increase back-stick pressure. This increases weight on the main gear and helps prevent the nose gear from digging in, however, do not allow the nose gear to lift off the runway. Continually increase back-stick and brake pressure as the aircraft decelerates. Always brake in a straight line; do not turn and brake. Maintain directional control with rudder and/or brakes. Use caution to avoid over-controlling when applying brakes.

Maintain crosswind controls throughout the landing roll. As the airspeed decreases, crosswind control deflection must increase to achieve the same effect. Proper use of aileron prevents a crosswind from lifting the upwind wing. When rudder effectiveness is lost, full aileron deflection may be necessary.

Confirm N1 reduction from 67-60% shortly after main gear touchdown (approximately 4 seconds).

Do not select NWS until the aircraft is at normal taxi speed. Center rudder pedals before selecting NWS. At higher speeds, NWS is extremely sensitive. Before reaching taxi speed, use NWS only if directional control cannot be maintained with rudder and brakes.

If you encounter nose wheel shimmy during the landing roll, apply back-stick pressure to relieve weight on the nose wheel, and then gently release pressure to reestablish nose wheel contact with the runway. If condition persists, reapply back-stick pressure. Strong crosswinds, a low strut, or a low runway condition reading (RCR); for example, wet or icy runway, all influence controllability after landing.

The physical limitations of the tire and brake system make it extremely difficult to consistently achieve optimum braking action, particularly at high speeds as lift reduces the weight component. A single, smooth application, with increasing pressure as airspeed decreases, offers the best braking potential. At speeds below 80 KIAS, the chances of approaching optimum braking action are greatly increased. Use caution when braking at speeds above 80 KIAS. Do not allow the wheels to lock during braking. Once a wheel is locked, it may be necessary to completely release brake pressure to allow wheel rotation.

At taxi speed, engage the NWS prior to initiating turns. Do not complete any After Landing Checklist items until clear of the runway.

Touch-and-Go Landing. When making touch-and-go landings, utilize the P.A.T. principle by smoothly applying the power to MAX without delay, hold the landing attitude, and trim nose down to reduce stick forces as the aircraft accelerates. Relaxing too much forward stick pressure on the go could cause nose wheel shimmy, and should be avoided on all Landings. Anticipate the need for right rudder pressure as the engine spools up. As power becomes available following engine spool-up, and with 85 KIAS minimum, raise the nose to the takeoff attitude and allow the aircraft to smoothly take off. Once a positive rate of climb is confirmed, retract the flaps (leave gear down).

Re-trim and climb out at 120 KIAS. When number one upwind with interval, make a crosswind call on the radio (as required) and commence a turn to the downwind leg using 30-45° AOB. Fifty feet prior to pattern altitude, begin the transition to level off at pattern altitude by reducing power to approximately 31% torque, then lowering the nose to maintain 120 KIAS and trim.

NOTE

Retraction of flaps from the TO to the UP position is not recommended below 110 KIAS to preclude the aircraft from settling back to the runway. However, there is no minimum to raise the flaps from the LDG to the TO position.

3. Procedures.

a. Landing Transition to Touchdown

- i. Approaching touchdown (5-10' AGL) smoothly reduce PCL towards idle.
- ii. Coordinate gradual back-stick pressure to land smoothly on the main mounts in a nose-high attitude. No higher than T/O attitude (~8 ° nose high) to preclude a tail strike.

b. Roll-out

- i. Maintain flared back-stick pressure. As speed decreases you will feel a corresponding loss of lift. As the nose begins to settle, slightly reduce back-stick pressure and allow the nose to smoothly touch down.
- ii. Maintain directional control using rudders only.

c. Full-Stop Landing

- i. Smoothly move the PCL to idle. Smoothly lower the nose gear to the runway once airspeed is below 80 kts.
- ii. With the nose gear on the runway and below 80 kts, smoothly apply brakes and increase back-stick pressure. This increases weight on the main gear and

helps prevent the nose gear from digging in, however, do not allow the nose gear to lift off the runway. When executing a normal full stop landing, check airspeed and verbalize “Airspeed below 80 kts” before initiating smooth braking. Use the double the board method to determine approximate appropriate airspeed control during a normal full stop landing roll. Speed should be between 60-70 kts with three thousand feet remaining (3 board), 40-50 kts with 2000 feet remaining (2 board) and 20-30 kts with 1000 feet remaining (1 board). If these speeds cannot be met, execute a touch and go with sufficient runway remaining based on the TOLD. Maintain aircraft control while expediting rollout to the end of the runway. Turn off the runway once the aircraft is safely under control at taxi speed.

- iii. Continually increase back-stick and brake pressure as the aircraft decelerates. Always brake in a straight line; do not turn and brake. Maintain directional control with rudder and/or brakes. Use caution to avoid over-controlling when applying brakes. Confirm N₁ reduction from 67-60% shortly after main gear touchdown (approximately 4 seconds).
 - iv. Do not select NWS until the aircraft is at normal taxi speed. Center rudder pedals before selecting NWS. At higher speeds, NWS is extremely sensitive. Before reaching taxi speed, use NWS only if directional control cannot be maintained with rudder and brakes.
- d. **Touch-and-Go Landing**
- i. Move PCL to full forward without delay. As power becomes available following engine spool-up, apply right rudder, and with a minimum of 85 KIAS raise the nose to the takeoff attitude.
 - ii. Execute a normal takeoff. Once a positive rate of climb is confirmed, raise flaps from LDG to TO (if applicable), and once airspeed is 110 KIAS minimum, retract the flaps (leave gear down). Trim.
 - iii. As airspeed approaches 120 KIAS, reduce power to 60-70% and climb straight ahead.
 - iv. Once trimmed at 120 KIAS and with proper interval, make the crosswind radio call and begin the crosswind turn using approximately 35 degrees AOB.
 - v. Rollout on downwind with $\frac{3}{4}$ - 1 WTD spacing from the runway.
 - vi. 50 feet prior to pattern altitude, transition to level flight by reducing power to ~31%.
 - vii. Once established on downwind, complete the Before Landing Checklist.

4. **Common Errors.**

- a. Uncoordinated transition with power reduction and nose attitude, resulting in a rapid or late flare.
- b. Landing too short or too long.
- c. Floating, ballooning, bouncing and full-stall landings.
- d. Excessive sink rate due to excessive power reduction.
- e. Not executing a wave-off for any unsafe condition.

608. CROSSWIND APPROACH

1. **Description.** Compensate for crosswinds in the landing pattern to maintain the normal ground track.

2. **General.** All pilots should be able to assess crosswinds and understand how they affect pattern operations. The proper application of crosswind controls is essential to executing landings. Consider using TO Flaps if crosswinds are greater than 10 knots or during gusty wind conditions. Consider using no flaps if crosswinds are greater than 20 knots and landing distance is not a factor.

Overshooting. Overshooting crosswinds will cause the aircraft to fly a track outside the normal final ground track. Ground speed in the final turn will be higher than normal. As a result, slightly lower than normal power settings and slightly more angle of bank will be required around the final turn to compensate for a higher required rate of descent.

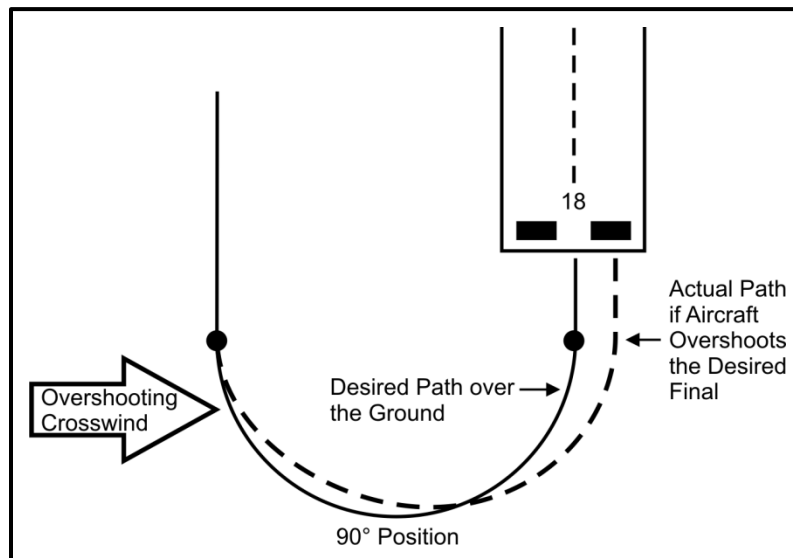

Figure 6-7 Overshooting Crosswind

Undershooting. Undershooting crosswind will cause the aircraft to fly a track inside the normal final ground track. Ground speed in the final turn will be lower than normal. As a result, slightly higher than normal power settings and slightly less angle of bank will be required around the final turn to compensate for a lower required rate of descent.

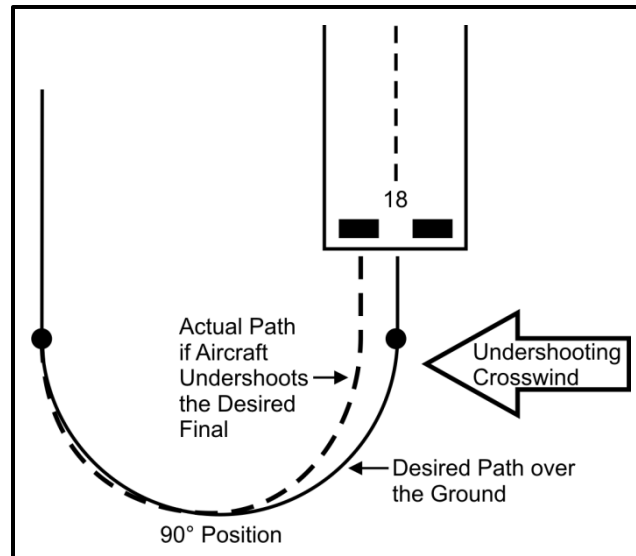

Figure 6-8 Undershooting Crosswind

In order to maintain a particular track or desired path over the ground, it will be necessary to “crab” or turn into the wind slightly. Therefore, when climbing out upwind or flying downwind, to maintain the desired path over the ground, you must crab into the wind slightly (Figures 6-9 and 6-10).

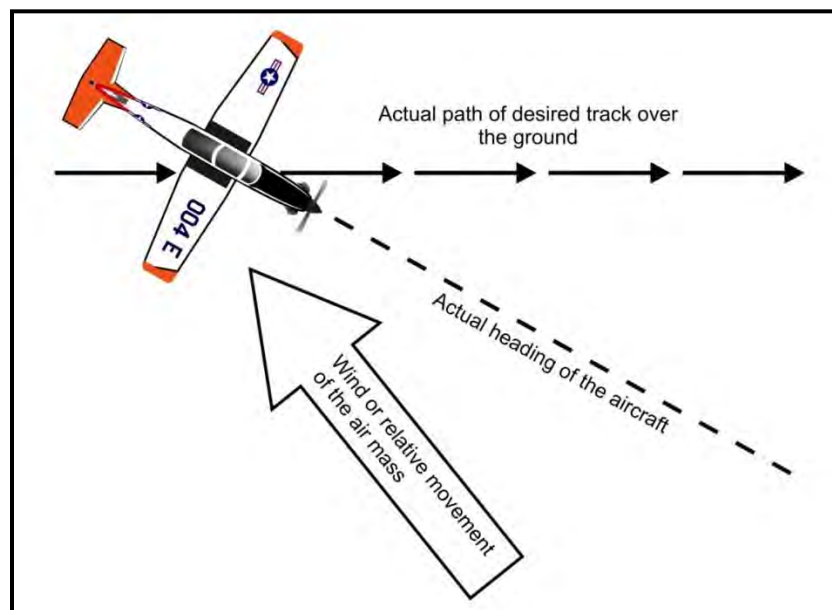

Figure 6-9 Crabbing

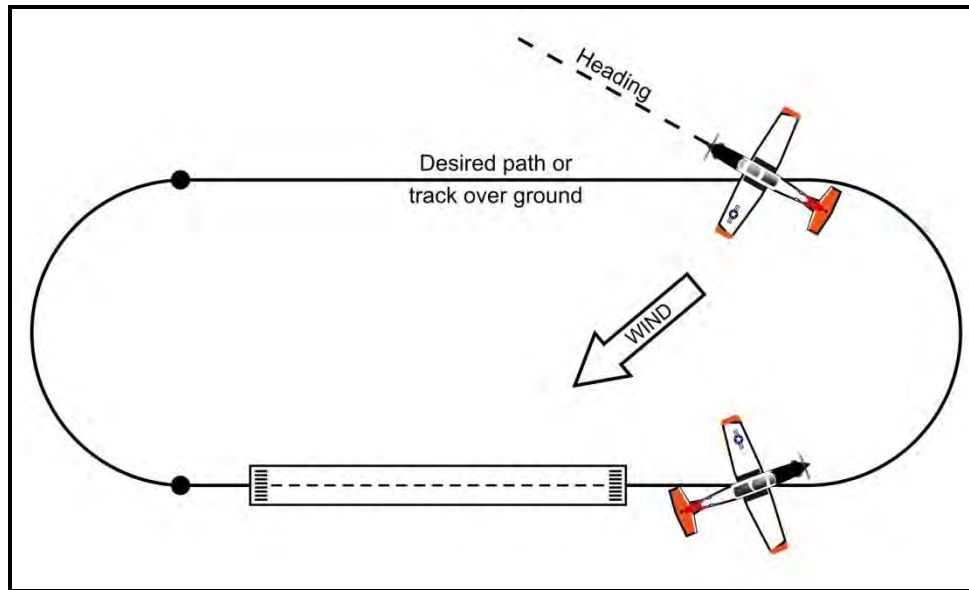

Figure 6-10 Desired Path

Final Turn. The normal Angle of Bank used at the start of the final turn should be approximately 30° . For overshooting winds, increased bank may be required to avoid overshooting final. While 45° of bank is acceptable if required, caution must be exercised as stall speed increases with increasing bank angle. Do not exceed 45° bank during the final turn.

If bank required to complete the final turn is greater than 45° , initiate a waveoff.

For undershooting winds, you may be required to use less bank to avoid angling on final and rolling out too close to the runway. Vary the angle of bank, power setting, or both in order to arrive at the extended runway centerline 1200-1500 feet from the runway threshold, and 100-150 feet of altitude at the proper airspeed.

NOTE

It is imperative to roll out at a proper distance from the runway to ensure enough time to assess the crosswinds and apply proper crosswind controls.

During gusty wind conditions, increase final approach airspeed by $\frac{1}{2}$ the gust factor up to a 10 knot increase. For example, with 8 knots of gust, increase final approach airspeed by 4 KIAS.

Final. After rolling out on final, utilize aileron inputs to maintain the aircraft on extended runway centerline, and rudder to maintain aircraft alignment with the runway. Additional power will likely be required for the increased drag caused by aileron and rudder inputs.

Wing-low. After rolling out on final, transition to the wing-low method by applying:

- a. Aileron into the wind as necessary to keep the aircraft from drifting left or right of the runway centerline.
- b. Rudder deflection to align the longitudinal axis of the aircraft with the runway.
- c. Additional power, as required, to counteract increased drag due to cross controls.
- d. Maintain wing-low control inputs throughout flare and landing roll out or touch-and-go.

3. Procedures

- a. Crab into wind on the downwind to establish proper WTD from runway centerline.
- b. Adjust power and bank angle to fly a normal ground track in the final turn.
- c. Execute a waveoff if unable to avoid overshooting final without using more than 45° angle of bank.
- d. Upon intercepting the extended runway centerline after rolling out on final, observe the magnitude of drift and establish the proper correction.

4. Common Errors

- a. Not recognizing when a crosswind exists.
- b. Utilizing improper crosswind control inputs.
- c. Not executing a waveoff when appropriate.

609. CROSSWIND LANDING

1. **Description.** Compensate for crosswinds and land smoothly at the intended point of landing on runway centerline.

2. **General.** Throughout the final, flare and touchdown, the aircraft should track in a straight line down the runway. The application of crosswind correction must be continued as necessary during the landing transition and flare to prevent drift. Since airspeed decreases as the flare progresses, the flight controls gradually become less effective; as a result, the crosswind correction being held will become inadequate. When using the wing-low method, it is necessary to gradually increase deflection of aileron into the wind as the aircraft decelerates. As torque decreases, the nose of the aircraft will yaw right. This yaw must also be accounted for on final.

Do not level the wings; keep the upwind wing down throughout the flare. Think of flaring over one wheel. As the forward momentum decreases, the weight of the aircraft will cause the other main wheel to settle onto the runway. If the wings are leveled prior to touchdown, the airplane will begin drifting and the touchdown will occur while drifting.

During gusty or high wind conditions, extreme caution should be used to make certain that the aircraft is not drifting or crabbing. A crab is a condition that occurs when a touchdown is executed while the longitudinal axis of the aircraft is not aligned with the runway. Since the aircraft is actually traveling sideways in relation to the runway, it will impart a tipping moment in the direction that the aircraft is traveling. Touchdown in a crab or drift will also cause the aircraft to turn away from the intended landing path. This turn is called a swerve. Any time a swerve develops, centrifugal force will be created commensurate to the speed of the swerve. It is dangerous to land in a crab or drift and could potentially cause the aircraft to depart the runway. ***If unable to apply proper crosswind controls before touchdown, or an uncontrollable drift occurs during the flare, WAVEOFF!***

Full Stop. During the landing roll, special attention must be given to maintaining directional control with rudders while maintaining crosswind aileron inputs. While the airplane is decelerating during the landing roll, ***more and more aileron must be applied to keep the upwind wing from rising***. Since the airplane is slowing down, there is less airflow over the ailerons and they become less effective. At the same time, the relative wind is becoming more of a crosswind and exerting a greater lifting force on the upwind wing. Consequently, when the airplane is coming to a stop, the aileron control must be held fully towards the winds. Maintain directional control with rudder and/or differential braking while applying aileron deflection into the wind. ***If landing occurred off runway centerline, do not attempt to aggressively correct back toward the center of the runway! If the aircraft becomes uncontrollable after initial touchdown, WAVEOFF.***

Touch-and-Go. Hold crosswind inputs on the deck and apply upwind aileron to maintain a wings level attitude. Initiate positive (firm) rotation when flying speed is reached to avoid side-slipping. Initial drift correction is made by turning into the wind with a shallow bank to counteract drift, then rolling wings-level. On the climbout, it will be necessary to “crab” the aircraft into the wind to maintain runway heading.

3. Procedures.

- a. Maintain crosswind correction through the landing transition using slight adjustments of rudder and aileron as necessary.
- b. Apply rudder as required to align the aircraft with the runway. Increase aileron pressure as necessary to land the aircraft with zero side motion.
- c. Add power as required to maintain proper aimpoint and airspeed due to the increased drag.
- d. Landing will be made on the upwind main mount first.

- e. Maintain crosswind corrections to minimize weathervaning and lower the nose to the runway.
- f. For full stop landings:
 - i. Increase aileron into the wind as the airplane decelerates.
 - ii. Use rudder as required to continue straight down the runway.
 - iii. Smoothly apply brakes below 80 KIAS. Maintain directional control with rudder and/or brakes while applying aileron deflection into the wind.
- g. For touch-and-go landings:
 - i. Hold in crosswind controls throughout ground roll.
 - ii. Advance PCL to MAX.
 - iii. Rotate the aircraft to the takeoff attitude at 85 KIAS (minimum).
- h. If unable to apply proper crosswind controls before touchdown, or an uncontrollable drift occurs during the flare, WAVEOFF!

4. **Common Errors.**

- a. Landing with any side motion.
- b. Landing in a crab.
- c. Not holding in corrections while on the runway.
- d. Not executing a waveoff when necessary.
- e. Overcorrecting back towards runway centerline.
- f. Not increasing aileron deflection into the wind during a full stop.
- g. Not crabbing upwind after a touch-and-go, causing a drift from runway centerline.
- h. Not checking airspeed before applying brakes.

610. WAVEOFF (GO-AROUND)

1. **Description.** The waveoff is a set of standard procedures used to effect the safe discontinuation of an approach.
2. **General.** Occasionally, during your landing practice, you will have to discontinue an approach and execute a waveoff. A waveoff may be initiated by the pilot, or may be directed by an external source (RDO, wheels watch, waveoff lights, IP, tower, another aircraft, etc.). The reason for an externally directed waveoff may not be apparent to the pilot, but the waveoff is mandatory unless a greater emergency exists. Do not confuse a waveoff with a stall recovery. If a stall indication occurs in the landing pattern, disregard ground track and execute the stall recovery procedures. After safely climbing away from the ground, reestablish the proper ground track and execute a waveoff.

Although a landing approach may be aborted at any point in the pattern, a waveoff will usually be executed during the approach turn, in the straightaway, or during the landing transition. Of course, the sooner a poor landing condition is recognized and the waveoff executed, the safer it will be. Do not delay the decision to waveoff and do not try to salvage a bad approach. If at any time your approach does not feel comfortable or you are too close to the aircraft in front of you, "take it around." You should not wait until the last second to make a decision. Keep in mind that a waveoff is not an emergency procedure unless it is executed too late. A pilot who recognizes a poor approach situation and executes a proper waveoff well before getting into a dangerous situation is demonstrating maturity and good judgment. Be alert for a waveoff given by wheels watch (radio call or waveoff lights). Once you have initiated a waveoff, do not change your mind and attempt to land.

Examples of an unsafe approach are unsafe altitude, unsafe airspeed, overshooting approach, drifting or crabbing prior to touchdown, and high transitions that will lead to a bounced landing. The sooner a poor landing condition is recognized and the waveoff executed, the safer it will be. Prior to the flare and touchdown, stick shaker activation inside the 90 position of the normal landing pattern or inside Base Key of the ELP requires immediate initiation of a waveoff.

Conflicts in the traffic pattern and insufficient separation during the landing approach are usually solved by establishing proper interval in the break or upwind prior to the crosswind turn; however, the following guidelines should be followed.

If you roll out in the straightaway before the aircraft has landed, an immediate waveoff shall be initiated. Do not delay your waveoff in hopes that the situation will correct itself. During operations at outlying fields where Practice Precautionary Emergency Landing (PPEL), PPEL in the pattern, and touch-and-go are in progress simultaneously, pilots must be constantly alert for traffic conflicts. ELP traffic has the right-of-way over normal touch-and-go traffic.

3. **Procedures.**
 - a. Advance PCL; MAX power may not always be required. Aircraft deconfliction, maneuvering requirements, and traffic pattern may warrant the use of something other than MAX power.

- b. Simultaneously level the wings (if conditions permit), and center the ball.
- c. Raise the nose to climbing attitude and climb at 120 KIAS. Re-trim.

NOTE

When the aircraft is under control, make a radio transmission that you are waving off.

- d. If flaps were lowered, when safely airborne at or above 110 KIAS and a positive rate of climb, raise the flaps and then accelerate to 120 KIAS. Reduce power to 60-70%, re-trim.
- e. Adjust your flight path, moving to either side of the runway if necessary, to avoid conflicting traffic and to keep aircraft on the runway in sight. Comply with any instructions given to you from the tower/RDO. If the wave-off was performed on final or during the landing transition with no other aircraft on the runway, the wave-off may be performed directly over the runway (unless prohibited by SOP).

NOTE

Wave-off shall continue to follow ground track to avoid traffic and comply with local course rules.

- f. With interval, call crosswind to re-enter downwind or depart the pattern.

4. Common Errors.

- a. Failure to initiate waveoff early enough.
- b. Failure to advance PCL as required.
- c. Failure to establish aircraft in a positive rate of climb.
- d. Failure to maintain 120 KIAS.
- e. Forgetting to raise the flaps.
- f. Forgetting to transmit waveoff call.
- g. Failure to maintain solid lookout doctrine and keep other aircraft in sight.

611. LANDING ERRORS

1. **Description.** A deviation from a normal landing which could cause a dangerous situation to quickly develop.

2. **General.** Airspeed in the flare is only slightly above stall airspeed. Even at slow airspeeds, the elevator is still very effective. An abrupt change in pitch could result in a balloon, a bounce, or even a stall. When any of these conditions are encountered, apply MAX power, adjust the pitch attitude and WAVEOFF if it is unsafe to continue the landing. If power is applied and the aircraft continues to settle, do not try to hold it off by raising the nose above the landing attitude. Hold the landing attitude and let the aircraft touch down. MAX power cushions the touch down. In case of a hard landing, do not raise the gear. The following are examples of landing errors.

a. **High Flare:**

Cause. Flare begun or performed too early or with excessive pitch up.

Effects.

Inability to flare normally due to excess altitude.

Possible premature touchdown of nose gear caused by abrupt pitch down to compensate for high flare.

Stall if flare continued with excess altitude.

Hard landing due to high sink rates as airspeed decreases at higher than normal altitude.

Recovery. With adequate airspeed and runway remaining, release a small amount of backpressure to increase descent rate. As aircraft approaches normal altitude, increase backpressure to reestablish normal flare.

If too high on final, causing an excessively steep glideslope, do not attempt landing, WAVEOFF. Remember, as landing attitude is attained, the aircraft is rapidly approaching a stall and there is insufficient margin-of-error for radical pitch changes in the flare.

b. **Late or Rapid Flare:**

Cause. Higher than expected descent rate or misjudged altitude.

Effects.

Firm touchdown due to higher than normal descent rates or insufficient time to complete flare.

Abrupt flare to prevent premature or firm touchdown may lead to an accelerated stall. This is a dangerous situation that may cause an extremely hard landing and damage to the main gear. This may or may not be a controllable situation, depending on airspeed.

Recovery. Hold landing attitude and add power. Immediate use of power increases thrust, lift, and controllability while simultaneously decreasing AOA and enables a recovery and waveoff. The main gear may contact the ground a second time, but if recovered properly, the second contact is usually moderate.

c. **Porpoising:**

Cause. Incorrect (flat) landing attitude and airspeed. At touchdown, the nose gear contacts the runway before the main gear.

Effects.

The aircraft bounces back and forth between the nose gear and main gear. Without immediate corrective action, the porpoise progresses to a violent, unstable pitch oscillation. Repeated heavy impacts on the runway ultimately cause structural damage to the landing gear and airframe.

Recovery. Immediately position the controls to the takeoff attitude (spinner approximately on the horizon) to prevent the nose wheel from contacting the runway and simultaneously advance the PCL to MAX and **WAVEOFF**.

Do not attempt to counteract each bounce with opposite control stick movement. The combined reaction time of pilot and aircraft is such that this control movement aggravates the porpoise. Hold the controls in the recovery position to dampen the oscillations. Power increases control effectiveness by increasing airspeed.

d. **Floating:**

Cause. Late power reduction, excessive airspeed, or improper flap setting.

Effects. Long landing. Possible balloon or bounce.

Recovery. Dependent on magnitude of float and runway remaining.

For a slight float, gradually increase pitch attitude as airspeed decreases and landing speed is approached.

Avoid prolonged floating, especially in strong crosswinds. If a long landing (outside safe landing zone) is inevitable, **WAVEOFF**.

e. **Ballooning:**

Cause. Rapid flare. Rapidly raising the nose to the landing attitude with excessive airspeed.

Effects. Altitude gain (dependent on airspeed and pitch rate).

Recovery. Landing may be completed from a slight balloon. Hold landing attitude as the aircraft settles to runway. Maintain wing-low crosswind controls through the balloon and landing. **WAVEOFF** from a pronounced balloon. Do not attempt to salvage the landing.

f. **Bounce:**

Causes.

Overly firm or hard touchdown causes aircraft to bounce off runway.

Contact with ground before landing attitude is attained. Landing with excessive rate of descent/energy.

Late recognition that aircraft is settling too fast, combined with excessive back-stick pressure.

Effects. Height reached depends on the force with which the aircraft strikes the runway, the amount of back-stick pressure held, and the speed at touchdown.

Recovery. Same as a balloon, depending on severity of bounce.

Slight Bounce. Continue the landing. Maintain direction with wing-low crosswind controls and smoothly adjust pitch to the landing attitude just before touchdown.

Severe Bounce (aircraft rising rapidly). Do not attempt a landing, **WAVEOFF** immediately.

Simultaneously apply MAX power, maintain direction, and set a safe pitch attitude. Continue waveoff even if another bounce occurs.

Bouncing in Crosswinds. Use extreme caution. When one wheel strikes the runway, the other wheel touches down immediately after. The crosswind correction is lost and the aircraft drifts. Reestablish crosswind controls to stop the drift and either continue the landing or waveoff, depending on the situation.

g. **Landing in a Drift or Crab:**

Cause. Failure to apply sufficient wing-low crosswind corrections.

Effects. Excessive side loads on landing gear and potential gear damage.

Recovery. **WAVEOFF** if unable to apply proper crosswind controls before touchdown.

h. **Wing Rising After Touchdown:**

Cause. Lift differential combined with rolling moment. During crosswind landing, airflow is greater on the upwind wing because the fuselage reduces airflow over the downwind wing. This causes a lift differential. The wind also strikes the fuselage on the upwind side and this causes a rolling moment about the longitudinal axis, which may further assist in raising the upwind wing. When effects of these two factors are great enough, one wing may rise even though directional control is maintained.

Effect. Depending on the amount of crosswind and degree of corrective action, directional control could be lost. If no correction is applied, one wing can raise enough to cause the other wing to strike the ground.

Recovery. Use ailerons to keep the wings level. Use rudder to maintain directional control. As the wing rises, the effect increases as more wing area is exposed to the crosswind.

612. OUTLYING FIELD DEPARTURE

1. **Description.** The outlying field departure (OFD) is a series of uniform procedures by which aircraft depart the pattern.
2. **General.** Departure from outlying fields shall be conducted in accordance with local course rules. You are number one for departure when past the departure end of the runway (or as defined by local SOP), flaps up, and the aircraft upwind has either initiated the crosswind turn or raised the landing gear to depart.

NOTE

In order to depart, you do not have to be number one with interval, but you must be number one upwind. There is a difference.

3. **Procedures.**
 - a. Ensure you are number one upwind.
 - b. Aircraft shall be safely airborne and past the departure end of the runway (or as defined by local SOP) and 120 KIAS minimum.
 - c. Check airspeed below 150 KIAS.
 - d. Raise landing gear handle and ensure flaps are up. Report over ICS, "Gear up, flaps up at ____ knots."
 - e. Add power to MAX.
 - f. Transmit departure call (see local SOP).

- g. Comply with SOP/Course Rules for departure.

4. Common Errors.

- a. Not ensuring you are number one.
- b. Forgetting departure call.
- c. Not raising gear.
- d. Accelerating above 150 KIAS before raising gear.
- e. Not re-trimming.
- f. Deviating from course rules.

613. VFR STRAIGHT-IN APPROACH

1. **Description.** A VFR straight-in approach may be used at either military or civil airfields when use of the "break" (or "overhead" at civil fields) would be precluded or impractical due to weather, traffic, or local procedures. These type approaches may also be used in conjunction with certain emergencies (e.g., in-flight damage).

2. **General.** Every straight-in approach will be different, depending on altitude and aircraft position relative to the runway. These factors may be influenced by weather, traffic, approach and/or tower controllers, etc. The pilot must use his/her judgment and experience to adjust the aircraft's flight path and/or configuration to safely and efficiently execute the approach and landing.

Miscellaneous. It is necessary to become familiar with and understand certain terms used in aviation not common to Naval Aviation. Since the racetrack landing pattern is peculiar to Naval Aviation, a pilot may encounter the more common "box" pattern at a non-Navy field or any time a non-break entry is made to any field (i.e., visual approach, instrument approach, etc.).

Figure 6-11 illustrates the typical box pattern and its terminology. Base leg should always be referred to as "left base" or "right base," depending on the direction on the turn to final (i.e., a left base would mean a left turn to final).

3. Procedures.

- a. Establish contact with ATC to communicate your request and/or intentions. If at a tower-controlled field, contact tower when instructed to by Approach Control or prior to entering the Airport Traffic Area.
- b. Fly the aircraft in an appropriate altitude and airspeed to a position approximately 2-3 miles from the runway on an extended runway centerline or extended base leg.

- c. Transition to the landing approach configuration by slowing below 150 KIAS, lowering the landing gear and completing the Before Landing Checklist. This should be done no later than base leg (if used) or a two - three mile final.
- d. If required, make the appropriate radio call to the tower or RDO. If at a tower-controlled field, obtain landing clearance prior to landing and report landing gear down and locked. Check the winds!
- e. Fly to intercept a stabilized glideslope (400-600 feet per NM) at 110/105/100 KIAS, 1200-1500 feet of straightaway from the threshold, and 100-150 feet AGL, wings level.
- f. Continue the approach and landing as in paragraphs 606 and 607.

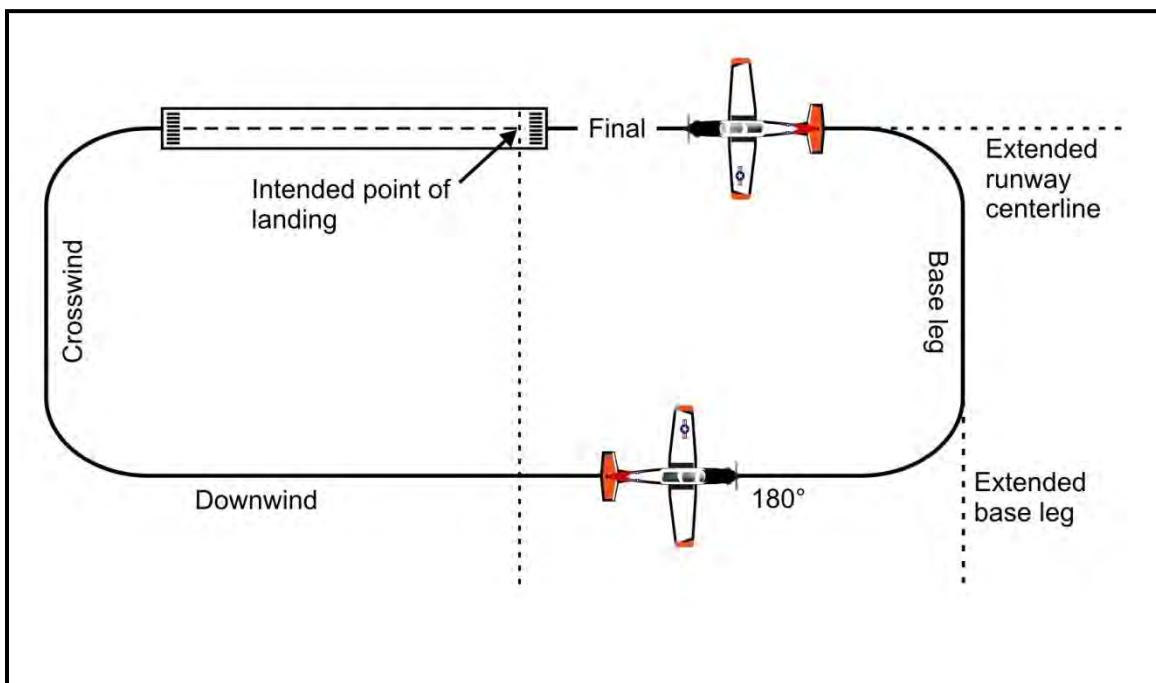

Figure 6-11 The "Box Pattern"

4. Common Errors.

- a. Not establishing radio contact with ATC soon enough.
- b. Transitioning to the landing configuration too late.
- c. Not making requested report to the tower.
- d. Landing without a clearance.
- e. Descending too early, resulting in a low, power-on approach.

THIS PAGE INTENTIONALLY LEFT BLANK

CHAPTER SEVEN EMERGENCY PROCEDURES

700. INTRODUCTION

This chapter forms the basis of your T-6B Emergency Procedures Training. A complete and thorough knowledge of the procedures in this chapter is essential for students who wish to progress to their solo flight. The memorization and proficient execution of these procedures will prove to be one of the greatest challenges to you during Primary Training. Remember the single most important factor in the execution of any emergency procedure is to first maintain control of the aircraft. After the aircraft is under control, you must then determine the precise nature of the problem. It is only at this point that you can execute the applicable emergency procedure and determine the appropriate landing criteria. No matter how well you know your procedures, if you lose control of the aircraft or misdiagnose the nature of the malfunction, you will not be successful in handling the emergency. Make sure that you are in control of the aircraft and understand what the problem is before you attempt to apply a solution.

1. **Description.** N/A
2. **General.** It is conceivable that during any flight evolution, an engine or system malfunction may occur either while on the ground or in flight. These malfunctions can range from system failures to a partial or complete power loss. The T-6B NATOPS Flight Manual, Section III, will be your governing publication for all EPs and the primary focus of your study and preparation. This chapter of the FTI merely expands and amplifies certain procedures from the NATOPS. If discrepancies exist between the FTI and the NATOPS manual, the NATOPS takes precedence.
3. **Procedures.** An emergency may occur at any altitude, airspeed and configuration. When presented with an emergency (actual or simulated), *follow the three basic rules for handling an airborne emergency.*
 - a. **Maintain aircraft control:** Establishing the aircraft in safe controlled flight should always be your first priority in any emergency, even if it means consciously continuing in straight and level flight. Conversely, if performing aerobatic maneuvers, for example, and the master caution light illuminates, accomplish the appropriate VMC recovery and take care of flying the airplane before delving into the specifics of the caution.
 - b. **Analyze the situation and take proper action:** Analyze the indications you have to determine the nature of the emergency. You should verify what you see in your cockpit with the other crewmember. Once the problem is diagnosed, apply boldfaced/asterisk items, then open your Pocket Checklist and with good aircrew coordination, continue with the emergency procedure. Consideration should be given to using RDO, FDO/ODO, or another aircraft for assistance as conditions persist.

- i. During airborne simulated emergency training, students will **VERBALIZE** the engine indications which may include Torque, ITT, N1, Np, Oil and Hydraulic pressure. Your instructor will verify indications and then give simulated engine indications and any EICAS messages that may apply.
- ii. The student will then determine the cause of the emergency and take appropriate action by simulating applying the appropriate checklist procedures.
- iii. Critical action items are to be conducted from memory without delay. Time permitting, break out the Pilot's Abbreviated Flight Crew Checklist (PCL) and conduct the appropriate checklist remaining items.

NOTE

During your airborne emergency procedure training, **DO NOT** actually manipulate switches or position the PCL to OFF in flight. When conducting simulated emergencies in flight, **VERBALIZE** emergency procedures that actually move switches or the PCL with the word "simulated." For example, use "PMU Switch" – "Simulated Off." In response to "PCL"-"Simulated Off," the instructor will set the power to 4-6% Torque to simulate a feathered propeller condition, when appropriate.

- c. **Land as soon as conditions permit:** The severity of the problem will dictate the course of action to take to safely recover the aircraft. Execution of emergency procedures will direct you to one of the following situations: Precautionary Emergency Landing (PEL), Forced Landing, Ejection, Land as soon as possible, or Land as soon as practical.

Land As Soon As Possible: An emergency shall be declared and a landing accomplished at the nearest suitable landing area considering the severity of the emergency, weather conditions, field facilities, ambient lighting, and command guidance.

Land As Soon As Practical: Emergency conditions are less urgent and, although the mission is to be terminated, the degree of the emergency is such that an immediate landing may not be necessary.

4. **Common Errors.**
 - a. Not maintaining aircraft control.
 - b. Improper analysis of aircraft malfunction
 - c. Not remembering to Aviate, Navigate, Communicate in that order.

- d. Executing incorrect emergency procedure.
- e. Not using appropriate CRM.
- f. Verbalizing procedures, but not executing.

701. ABORTED TAKEOFF DEMONSTRATION

1. **Description.** This maneuver demonstrates the characteristics and length of runway required for an aborted takeoff.
2. **General.** An aborted takeoff may be required during any takeoff. Examples of reasons for aborting a takeoff include blown tire(s), streaming fuel, fire light, chip light, fluctuating oil pressure, rapidly rising ITT or bird strike. Any situation which appears abnormal or unsafe during takeoff shall necessitate an abort.
3. **Procedures.**
 - a. Call tower for takeoff, stating intentions.
 - b. Position aircraft on runway for a normal takeoff.
 - c. When properly aligned on the runway (and cleared for aborted takeoff), add power to 30% and check instruments.
 - d. Release brakes, advance PCL to MAX, and commence normal takeoff roll.
 - e. Before 1500 feet of takeoff roll and prior to 60 KIAS, initiate the Aborting Takeoff procedure as described in the T-6B NATOPS Flight Manual. Use caution when applying brakes, smooth application of brake pressure will prevent overheating and blown tires.
 - f. Maneuver is complete when the aircraft has achieved a safe taxi speed. Taxi clear of runway.
4. **Common Errors.**
 - a. Delaying the abort procedure beyond 1500 feet or 60 KIAS.
 - b. Excessive brake pressure or pumping the brakes resulting in blown tires.

702. EMERGENCY LANDING PATTERN (ELP)

1. **Description.** The ELP is a 360° pattern designed to position the aircraft for landing at a prepared surface during a complete power loss (Forced Landing) or when an impending engine failure exists in which sufficient power for continued flight is available (Precautionary

Emergency Landing [PEL]). The ELP is used for both actual/simulated PEL and actual/simulated Forced Landings. If altitude permits, intercept the ELP at 3000 feet AGL (2500 feet AGL minimum per the T-6B Flight Manual).

2. **General.** If an engine failure or malfunction in flight requires a Forced Landing or a PEL, a thorough understanding of T-6 flight performance, emergency procedures, ELP, and ejection system capabilities is critical in the decision to eject or attempt completing the ELP to touchdown. If there is any doubt about engine performance, or there is benefit to remaining in the ejection envelope longer, consider recovering using the ELP. The time available to decide whether to recover via ELP or eject depends on the phase of flight. Time available can range from a few seconds to over 20 minutes for a high-altitude engine malfunction. ELPs are only flown to suitable landing areas (hard surface runway, taxiway, under run, or overrun) of sufficient length. Landing on an unprepared surface should only be attempted if ejection is not possible.

In an actual engine failure scenario, the methodology to descend below the minimum controlled ejection altitude employs a series of critical decisions. With an actual failed engine, T-6B aircrews will not descend below 2000 feet AGL unless they are on profile for a suitable landing area, with the runway in sight and in a position to safely maneuver to land. Do not delay the decision to eject in an unlikely attempt to land on an off duty runway if engine failure occurs while configured in the normal landing pattern.

Distractions resulting from excessive troubleshooting or time-consuming attempts to regain power during the execution of the ELP may cause substantial deviation from the standard pattern, precluding a safe landing at the selected site.

ELP Types. The depicted profile (Figure 7-1) is used for both Forced Landings and a PEL. The difference between a Forced Landing and a PEL is power available. The Forced Landing is flown with the engine inoperative (no power), or when power is insufficient for continued flight. The PEL is flown with power available, although engine failure may be imminent or power available may be less than normal.

If flown correctly, the Forced Landing and PEL look the same. However, methods to correct for low energy states differ. For a Forced Landing, correct for low energy by delaying landing gear or flap extension, intercepting the ELP at some point other than high key (low key, base key, final), and/or adjusting pattern ground track. For a PEL, immediately use power available to correct for a low energy state as soon as it is recognized and do not delay configuration.

3. **ELP Descent to High Key.** Turn immediately to the nearest suitable field based on aircraft condition, weather, airfield conditions, altitude, and gliding distance available.

Glide Performance. Best glide speed with the aircraft in a clean configuration is ~125 KIAS with a sink rate (VSI) of ~1350 to 1500 fpm. A clean glide at 125 KIAS approximates best glide range. For no-wind planning, a clean aircraft (prop feathered or 4-6% torque set) at 125 KIAS should be capable of a glide ratio of ~2 nautical miles for every 1,000 feet of altitude lost.

Landing gear down with flaps and speed brake retracted, your best glide speed is ~105 KIAS with a sink rate of 1500 fpm and a glide ratio of ~1.6 nautical miles for every 1,000 feet of altitude lost.

- a. In an actual PEL situation, check the descent rate after setting 4-6% torque (clean configuration). If VSI is greater than 1,500 fpm, increase torque to achieve a 1,350 fpm descent. If power is insufficient to achieve a descent rate less than 1,500 fpm, consider shutting down the engine to improve glide performance.
- b. If time permits, use DME or FMS to confirm the actual glide ratio. Consider winds and required turns. Adjust the plan if actual glide distance varies from expected.
- c. If unable to climb or zoom, the aircraft travels approximately 0.1 to 0.2 nautical miles of horizontal distance for every 10 knots of excess airspeed above 125 KIAS in a level deceleration. For example, at 200 KIAS the aircraft glides approximately 1.2 NM straight and level before slowing to 125 KIAS.
- d. Ten knots of extra airspeed can be traded for approximately 100 feet of increased altitude. For example, 175 KIAS and 6,000 feet is approximately the same energy level as 125 KIAS and 6,500 feet. Once on ELP profile, reduce power to 4-6% torque and maintain altitude as the airspeed bleeds off to 125 KIAS.

In the event of engine malfunction or failure, there may be more than one airfield within glide distance. Select the most suitable airfield based on the following factors:

- a. Distance to airfield.
- b. Terrain around airfield.
- c. Runway length, width, direction, and condition.
- d. Weather.
- e. Fire or rescue support.
- f. Emergency oxygen and electrical power supply. Time required for glide from high altitude with engine inoperative may exceed emergency oxygen supply.
- g. Threat to the public if aircraft must be abandoned/ejected.

Choosing the Most Suitable Field. Choose the closest suitable hard-surface field with a minimum of a 3000' runway to set up for the ELP. If multiple fields meet this criteria, other considerations such as crash crew support or medical assistance may be factored in.

Distance Calculations. A VFR chart, conventional NAVAIDS, and FMS NAV or TSD displays can be used when judging distance to the selected recovery airfield. The NRST function on the NAV and TSD FMS pages is extremely helpful in providing accurate distance information. Two primary methods used to determine energy state relative to emergency fields are:

- a. **DME Method.** Compare energy state relative to a specific field. A memory aid for this method is “1/2 DME + KEY+ Field Elevation.”
 - i. Determine distance to field using available resources. Distance to the airport displayed by the FMS is to the center point of the airfield and not to a specific runway.
 - ii. Distance divided by 2, add Field Elevation; this equals minimum AGL altitude required to reach field.
 - iii. Is current altitude (AGL) sufficient to reach the field?
 - iv. Add 3,000 feet (high key) or 1,500 feet (low key) to AGL altitude required.
 - v. Is energy sufficient to reach high or low key?
- b. **Altitude Method.** Compare energy state relative to more than one field.
 - i. Subtract 3000 foot (high key) or 1500 foot (low key) from AGL altitude; multiply by 2 to determine maximum glide distance to high or low key.
 - ii. Identify fields within glide distance to high or low key.
 - iii. Determine most suitable field.

Energy Management: Normally the ELP will be entered at high key, but the ELP can be intercepted at any point on the ELP profile between high key and final. Carefully manage energy to arrive at high key on altitude and airspeed. Attempt to dissipate excess energy prior to high key to minimize disorientation and allow the profile to be flown normally. If excess altitude exists during the glide to high key, lose energy by executing: 360° turns, bow ties, S-turns, slips, lower the gear early, extending the speed brake or use a combination of these methods. In a PEL situation, expeditiously maneuver towards high key while simultaneously dissipating energy as needed. All of these methods may be used for both PEL and Forced Landings at the pilot’s discretion.

- a. **360° turns prior to high key (PEL or Forced Landing).** This is generally accomplished very near or directly over the intended landing destination. Approximate altitude loss for 360° turns:
- 125 KIAS, Idle power:
- 30° bank - 3000-3500 feet.
- 125 KIAS, 4-6% torque or prop feathered:
- 30° bank - 2,000 feet.
- 45° bank - 1,500 feet.
- 60° bank - 1,000 feet.
- b. **Bow Ties.** Bow Ties are essentially a continuous set of mild turns in the shape of a bow tie flown approximately ½ wing tip distance (WTD) away and on the downwind side of the landing area. With each bow tie, you should attempt to keep the landing runway in sight. Bow ties are not precise maneuvers and different techniques exist on how to fly them. Your instructor will provide guidance; however, plan to depart the bow ties for high key with sufficient altitude remaining to glide to high key altitude.
- c. **Slips.** A slip is an out-of-balance flight condition used to increase the sink rate and lose excess altitude while maintaining a constant airspeed and a specific track over the ground. Use caution slipping when configured and close to the ground. The slip must be taken out carefully with enough altitude remaining (200-300 feet) to slow the rate of descent and ensure positive control of the aircraft during the final moments of the maneuver. Refer to Chapter 5 for slip procedures.
- d. **S-turns.** S-turns are used to affect a milder altitude loss and may be specifically used to make controlled corrections while proceeding direct to high key. Designed to increase the actual track over the ground, S-turns are simply lazy turns back and forth deviating from a straight-line ground track in order to provide more time to descend.
- e. **Lower the gear early or extending the speed brake.** In order to expedite entry into the ELP profile, lowering the gear early or extending the speed brake is a viable method to increase drag/descent rate during a high energy state while maneuvering to enter the ELP profile. Remember, your maximum glide distance changes if the engine fails with the gear down. Glide speed is ~105 KIAS with a sink rate of 1500 fpm and a glide ratio of ~1.6 nautical miles for every 1,000 feet of altitude lost.

POSITION	ALTITUDE	AIRSPEED	CONFIG	POSITION
HIGH KEY	2500-3000 feet AGL	120 KIAS	Gear Down Flaps UP	1/3 down the runway Offset up to 1/4 WTD
LOW KEY	1500 feet AGL		Gear Down Flaps TO	On runway heading 2/3 WTD (fuel cap on runway)
BASE KEY	600-800 feet AGL	120 KIAS Slowing to 110 KIAS(min)	Gear Down Flaps LDG (as required)	Perpendicular to landing line; halfway between low key and the runway
FINAL	Descending to land	110 KIAS		Runway centerline

Figure 7-1 Emergency Landing Pattern (ELP) Checkpoints

4. **Emergency Landing Pattern Profile.** The ELP profile is designed to position the aircraft for landing from a Forced Landing, PEL, or PEL from the pattern [PEL(P)] situation. See Figure 7-1 and Figure 7-2.

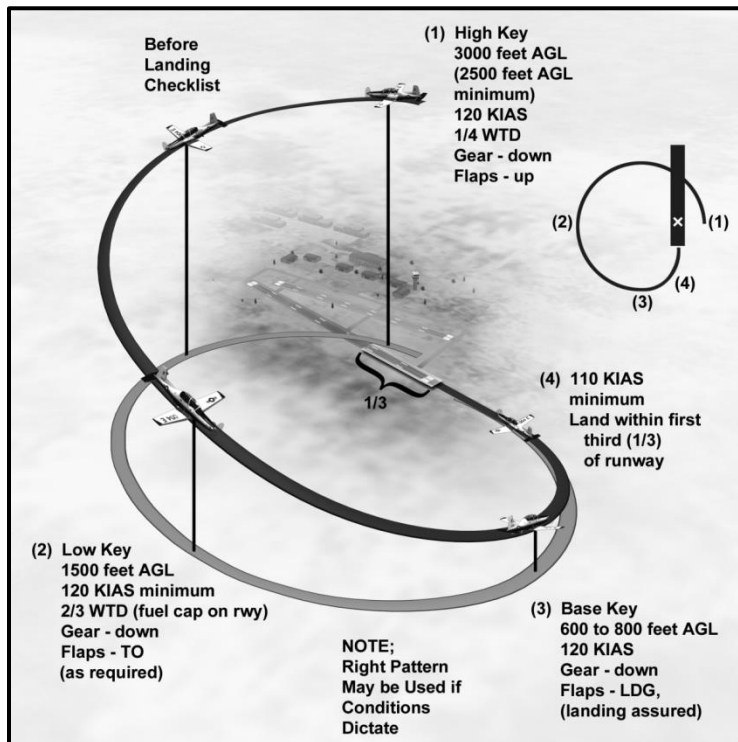

Figure 7-2 Emergency Landing Pattern

- a. **Planning.** The primary reference during an ELP is the runway. Crosscheck energy level (altitude + airspeed) with position. Look outside to maintain proper ground track. Predict energy level (altitude + airspeed) as early as possible at known reference points (high key, low key and base key) and anticipate required corrections. Position deviations can occur due to poor planning, imprecise aircraft control, or improper wind analysis. Trim throughout the ELP to minimize airspeed deviations. Make all corrections smooth and expeditious to avoid stall.
- b. **High Key.** Position the aircraft at high key, 2500-3000 feet AGL, 120 KIAS, gear down, wings level, aligned with the landing direction and approximately one-quarter WTD from the runway away from the intended ELP turn direction. Turn, using angle of bank as necessary (~ 15-20° in calm wind), towards the low key position. Maintain 120 KIAS and make appropriate voice call.
- c. **Low Key.** Located approximately two-thirds WTD (fuel cap on runway), abeam the intended point of landing (no wind), altitude approximately 1,500 feet AGL and 120 KIAS minimum.
 - i. Approaching low key, crosscheck the runway to evaluate spacing. Check winds on PFD and crosscheck with windsock. Plan final approach accordingly.
 - ii. At low key, level the wings momentarily and check for proper spacing and altitude. If energy is assessed to be adequate to make the runway, lower TO flaps (lower flaps no sooner than low key). If high energy state, lowering flaps to land will facilitate dissipating additional altitude or airspeed.
- d. **Base Key.** Maintain 120 KIAS minimum. The descent is normally greater than for a normal pattern. Fly the aircraft perpendicular to the runway (base key) at 600-800 feet AGL. Altitude is not the only indication of proper energy management; the distance from the runway must also be assessed and the effect of winds taken into account. When landing is assured, flaps may be lowered to LDG.
- e. **Final.** Aircraft may be slowed to 110 KIAS (minimum) on final. Maintain 110 KIAS (minimum) on final until transition to landing. The transition to landing may begin well prior to the intended point of touch down. Plan to land within the first one-third of the runway.

CAUTION

Use caution with low power settings on final, especially with LDG flaps. High descent rate with idle power setting, coupled with pitch change to intercept a normal glide path, could result in rapid decrease in airspeed. A high sink rate can develop, which may result in a stall or hard landing.

CAUTION

At high density altitudes, engine response is delayed. When low and/or slow on final, engine spool time may not allow for a timely recovery prior to a hard landing. Pilots must not accept a low energy state inside of low key and any delay to initiate a waveoff may result in an excessive rate of descent. Exceeding NATOPS limits for rate of descent at touchdown can lead to structural damage and landing gear component failure.

- f. **Landing.** Adjust the nose attitude in the flare to transition to a normal landing. Touch down on the main gear and then gently lower the nose wheel as in a normal landing. Apply braking as needed based on runway remaining.
- i. **PEL.** If runway remaining after touchdown is insufficient to stop, waveoff. If sufficient power is available to obtain low key, attempt a PEL(P). If power is insufficient or engine failure occurs, consider ejection.

NOTE

If the aircraft is below profile between high key and low key, add power to regain altitude (if available). MAX power may not always be appropriate depending on the amount of correction required. After base key, use normal power corrections to ensure a safe and controlled landing.

- ii. **Forced Landing.** Anticipate a longer flare and touch down due to reduced drag. Use caution when applying brakes to prevent blown tires. If the aircraft cannot be stopped before the end of the runway, execute the Emergency Engine Shutdown on Ground Procedure or Eject.

NOTE

Do not delay the decision to Eject (actual engine failure) or waveoff (simulated engine failure) after determining a safe landing is unlikely.

5. **ELP Wind Analysis.** Winds can cause ELPs to differ significantly from standard. An uncorrected/unanticipated strong wind component can result in an unsuccessful ELP, even if it was otherwise flown flawlessly.

- a. **Determining Winds.** Surface winds, winds at 1,000 to 3,000 feet, winds at 5,000 feet and winds aloft should be obtained from weather forecasts and serve as a good starting point for building situational awareness about actual wind conditions. The winds at 1,000 to 3,000 feet can vary significantly from surface winds and

significantly alter required ELP ground track. At tower controlled runways, actual surface winds are known. Other methods to determine the winds include:

- i. Radio calls to other aircraft, a fixed base operator (FBO) on the field, ASOS, etc.
- ii. Without access to actual observations, use winds briefed by weather forecaster in the preflight briefing as a starting assumption.
- iii. If performing an ELP at a non-towered airfield (NTA) without weather observation capability, assume that in the local area, surface winds will be similar to those at the home field.
- iv. Observation of surface conditions; smoke, waves on lakes, wind tetrahedron, windsock, etc.
- v. Double the surface wind velocity to estimate winds at high key as wind is typically stronger at altitude than at the surface.
- vi. Use PFD indications of wind speed and direction.

703. PRECAUTIONARY EMERGENCY LANDING (PEL)

1. **Description.** Use the PEL procedure to ensure that a safe landing at a paved field can be made if indications of an impending engine failure should occur.
2. **General.** Indications of an impending engine failure could be excessive vibration, smoke or fumes, chip detector annunciator light, fuel or propeller malfunction or any other condition listed in the T-6B NATOPS Flight Manual requiring that you land as soon as possible via PEL.

In most PEL situations (chip light, low oil pressure, etc.), time is the most critical element. The longer the engine runs, the greater the chance for complete failure. For this reason, every effort should be made utilizing energy management methods to safely expedite getting to high key with power. Don't turn a PEL into engine failure due to slow procedures or excessive troubleshooting!

The PEL checklist in the T-6B NATOPS Flight Manual offers an organized approach to recovery with an impending engine malfunction. A good memory aid for these steps (PEL checklist); "Turn, Climb, Clean, Check, BIP."

3. **Procedures.** The first three steps, "Turn, Climb, Clean," must be executed nearly simultaneously and without delay.
 - a. **TURN.** Turn in the general direction toward the nearest suitable field. Locate the field visually, use conventional NAVAIDS, FMS NAV/TSD displays, or FMS NRST

- to aid in determining nearest field. A good pilot should always know where the nearest field is located.
- b. **CLIMB or ACCELERATE.** If a climb is needed, climb at 140 KIAS using an appropriate power setting to achieve Dead Engine Glide Distance. If unable to climb due to clouds, icing, etc., increase energy by accelerating to a higher airspeed. Remain clear of clouds until in position to descend and/or decelerate to enter the ELP. If at high altitude, a descent will be required to enter the ELP.
 - c. **CLEAN.** Ensure aircraft is in a clean configuration by raising landing gear, flaps, and speed brake (as appropriate for the emergency) as soon as possible. Retraction may not be possible if the engine fails. Remember that excess drag inhibits the climb and greatly reduces gliding range.
 - d. **CHECK.** Conduct a systematic check of the aircraft and instruments for additional signs of impending engine failure.
 - e. **Boost Pump Switch** – as required.
 - f. **Ignition Switch** – as required.

NOTE

Turn boost pump and ignition switches ON unless an Airstart would not be warranted should the engine fail (oil system malfunction, chip light, fire light or FOD).

- g. **Plan:** To intercept the ELP in the appropriate configuration and a minimum speed of 120 KIAS. The above considerations and energy state should lead to one of three decisions:
 - i. Intercept the ELP profile at or above high key.
 - ii. Intercept the ELP profile at a point other than high key with the appropriate configuration and airspeed.
 - iii. Eject if it becomes clear that the aircraft cannot be safely recovered.
- h. Determine the duty runway at your landing site before intercepting the ELP profile.
- i. Deliver a simulated emergency voice report using ISPI format over ICS to the instructor. For an actual emergency, notify ATC/Tower/RDO over the radio of your situation/intentions.
- j. Reduce power to 4-6% torque once DEGA is reached.
- k. Lower the landing gear *no later than high key*.

- l. Report on ICS the Before Landing Checklist and re-trim for 120 KIAS.
 - m. At high key, turn toward the low key position using angle of bank as required to maintain ground track and make the appropriate radio call in accordance with local SOP. Maintain 120 KIAS.
 - n. Approaching low key, vary the angle of bank as necessary so as to arrive at a 2/3 wingtip distance abeam the intended point of landing. Level the wings momentarily to accurately check your position abeam.
 - o. At low key, set TO flaps and perform the low key voice report IAW local SOP. ***Lower flaps no sooner than low key.*** Use power as required to maintain energy state inside of the low key position.
 - p. Continue the turn towards the base key position. Vary angle of bank as necessary to arrive at a proper base key position (600-800 feet AGL, 120 KIAS).
 - q. Check and report, "Gear down, flaps TO (or LDG as required), speed brake retracted, Before Landing Checklist complete."
 - r. When landing is assured, flaps may be lowered to LDG.
 - s. Use normal power corrections as required to make a safe and controlled landing.
 - t. Decelerate toward 110 KIAS (minimum) after rolling out on final. Maintain 110 KIAS (minimum) on final until commencing the landing transition. Make an ICS call IAW local SOP.
4. **Common Errors.**
- a. Delaying turn toward the nearest suitable field during initial climb.
 - b. Excessive climb. Delayed arrival at high key, increased risk of engine failure during PEL.
 - c. Poor power control on PEL. Failure to set and maintain 4-6% torque once on ELP profile.
 - d. Poor airspeed control due to improper trim for 125 KIAS glide.
 - e. Improper position at high key (aircraft not aligned).
 - f. Excessive or insufficient bank angle at high key resulting in improper low key spacing.
 - g. Delaying configuration (gear/flaps) instead of correcting with power.

- h. Failure to compare actual and desired position and energy.
- i. Failure to anticipate or correct for wind.
- j. Failure to refer to Pilot's Abbreviated Flight Crew Checklist (Pocket Checklist) with time permitting.
- k. Failure to reduce power to idle during landing phase of PEL.

704. PRECAUTIONARY EMERGENCY LANDING FROM THE PATTERN

1. **Description.** Use PEL procedures if indications of an impending engine failure occur while in the landing pattern.
2. **General.** The same indications of an impending engine failure as discussed in the PEL may occur in the landing pattern. This maneuver affords the opportunity for the student to practice intercepting the ELP at low key while already established in the landing pattern.

The PEL in the pattern will be initiated at or above 400 feet AGL by the instructor informing the student that he or she has a simulated malfunction requiring that a PEL in the pattern be performed.

NOTE

This simulated PEL in the pattern should not be initiated until proper interval with both PEL and touch-and-go traffic is obtained.

3. **Procedures.**
 - a. **TURN** towards the nearest suitable runway. Consider the use of an off-duty runway. If the pattern is extended and/or the winds are calm, the nearest suitable runway may be the reciprocal of the runway the aircraft just departed. The instructor will then direct which runway will be used. Practice PELs in the pattern must conform with local course rules. The instructor will make the appropriate call to the Tower/RDO/crash crew.
 - b. **CLIMB** at 125 KIAS, utilizing power setting as appropriate for the simulated emergency.

NOTE

Anticipate immediate forward stick to maintain 125 KIAS should total engine power be lost.

- c. **CLEAN** up the aircraft, gear, flaps, and Speed brake – UP. Report "aircraft clean" to your instructor.

- d. **CHECK** Aircraft and engine instruments. Conduct a systematic check of the aircraft for secondary indications.
- e. **Boost Pump Switch** – As required.
- f. **Ignition Switch** – As required.

NOTE

Turn boost pump and ignition switches ON unless an Airstart would not be warranted should the engine fail (oil system malfunction, chip light, fire light or FOD)

- g. **Plan** – to intercept ELP at or above low key position.
- h. Determine or verify the intended runway with the instructor.
- i. Deliver the appropriate simulated emergency voice report using the ISPI format over ICS to your instructor. For an actual emergency, notify the tower/RDO of your situation/intentions on the radio.
- j. Reduce power to 4-6% torque once within dead engine gliding distance of a low key position. (Lower the nose to the 125 KIAS glide attitude and re- trim.)
- k. Lower the landing gear.
- l. Report over ICS the Before Landing Checklist and re-trim for 120 KIAS.
- m. Arrive at pattern low key with proper configuration (***lower flaps no sooner than low key***), altitude, and $\frac{2}{3}$ wingtip distance.
- n. Make the appropriate radio call at pattern low key IAW local SOP.
- o. Complete the maneuver as in the last half of the PEL.

NOTE

Any time the aircraft is below profile, add power as required to regain proper altitude/airspeed. After the base key position, use momentary power as required to regain profile.

4. **Common Errors.**

- a. Not maintaining 125 KIAS in the climb.
- b. Failure to use power when low throughout the pattern.

- c. Over climbing to low key, resulting in excessive altitude precluding a safe descent profile to landing.
- d. Failure to complete the Before Landing Checklist prior to low key.
- e. Failure to anticipate or correct for wind.
- f. Failure to reduce power to idle during landing phase of PEL.

705. ENGINE FAILURE DURING FLIGHT (POWER LOSS)

1. **Description.** A complete engine failure or insufficient power available to execute a PEL may occur at any airspeed, altitude or configuration. Fly (glide) to intercept the ELP profile while simultaneously executing the appropriate procedures. Identify the nearest suitable airfield and safely maneuver the aircraft to intercept the ELP. Arrive at high key aligned with the landing runway. If high key cannot be reached, intercept profile at some point on the ELP (low key, base key, final). Below 2000 feet AGL, make a timely decision to continue or eject.

2. **General.** The below guidance is geared towards an engine failure, airstart attempt not warranted and will guide you to a forced landing or ejection situation. If an airstart is warranted, and is successful, the end result of your procedures will direct you to execute a PEL. Refer to PEL procedures contained within section 704 of this chapter.

Carefully manage your energy state to arrive at high key on or slightly above altitude. Do not unnecessarily dissipate energy quickly with a failed engine. Use the extra time to formulate a plan that will maximize the possibility for success.

The Engine Failure During Flight procedures in the T-6B NATOPS Flight Manual offers an organized approach to recovery with an engine failure in flight. If the engine can't be restored to normal operations, you will need to decide whether to use the ELP and recover via a Forced Landing, or Eject if no suitable landing site is within reach using DEGA.

3. **Procedures.** After properly analyzing the malfunction as an engine failure, take proper action by executing the first four memory critical action items without delay.
- a. **ZOOM/GLIDE - 125 KIAS (MINIMUM).** Above 150 KIAS, zoom to capture 125 KIAS minimum. Below 150 KIAS, slow to 125 KIAS minimum as required. At high altitudes, smoothly decelerate to the 125 KIAS descent attitude to trade excess airspeed for glide distance. Raise landing gear, flaps and speed brake as soon as possible as retraction may not be possible as the engine spools down. ***Get to your best glide speed in a trimmed flight condition.***

NOTE

Crosscheck N1 against other instruments to assess condition of engine and determine if an airstart is warranted. **VERBALIZE** the

engine indications which may include Torque, ITT, N1, Np, Oil and Hydraulic pressure. Your instructor will verify indications and then give simulated engine indications and any EICAS messages that may apply. At 125 KIAS, an engine which has flamed out will rotate below 8% N1 and indicated 0% N1. The engine oil pressure indicator may display oil pressures up to 4 psi with an N1 of 0%

- b. **PCL - OFF** (IP will simulate PCL off by setting 4-6% torque).
- c. **INTERCEPT ELP.** As you are accomplishing steps one and two, begin turning towards the nearest field.
- d. **Airstart.** Attempt if warranted. You do not attempt an airstart if engine failure was due to fire or mechanical failure. Airstart procedure is not recommended below 2000 feet AGL, as primary attention should be to eject or safely recover the aircraft.

If conditions do not warrant an airstart.

- e. **FIREWALL SHUTOFF handle** – Pull.
- f. **Execute Forced Landing or Eject.**
The decision to execute Forced Landing procedures or Eject will depend upon having enough aircraft energy (at or above DEGA) to glide to a suitable landing area using the appropriate energy management methods mentioned within section 702 of this chapter.

If aircraft energy state is at or above DEGA to a suitable landing area, execute the Forced Landing procedures in accordance with the NATOPS Flight Manual.

With an actual failed engine, T-6B aircrews will not descend below 2000 feet AGL unless they are on profile for a suitable landing area, with the runway in sight and in a position to safely maneuver to land.

- g. Determine the duty runway at your landing site before intercepting the ELP profile.
- h. Deliver a simulated emergency voice report using ISPI format over the ICS to the instructor. For an actual emergency, notify ATC/Tower/RDO/Guard over the radio of your situation/intentions.
- i. Approaching high key, assess the winds and plan accordingly.
- j. Intercept the ELP profile at or above high key.
- k. If unable to intercept high key, intercept the ELP profile at another point with the appropriate configuration and airspeed.

- l. Lower the landing gear as required for energy state and accomplish the Before Landing Checklist.
 - m. At high key, turn toward the low key position using angle of bank as required and make the appropriate radio call (refer to local procedures). Maintain 120 KIAS.
 - n. Approaching low key, vary the angle of bank as necessary so as to arrive at a 2/3 wingtip distance abeam the intended point of landing. Level the wings momentarily to check your position abeam.
 - o. At low key, set TO flaps (if on profile) and perform the low key voice report (IAW local SOP). **Lower flaps no sooner than low key.** If flaps are delayed because of low energy state, use caution in the final turn because of increased stall speed. Do not slow below 120 KIAS.
 - p. Assess energy state approaching the base key position and determine if a safe landing can be made. If a safe landing is unlikely, EJECT (actual engine failure) or WAVEOFF (simulated engine failure).
 - q. Continue the turn towards the base key position. Vary angle of bank as necessary to arrive at a proper base key position (600-800 feet AGL, 120 KIAS).
 - r. Check and report, "Gear down, flaps TO (or LDG as required), speed brake retracted, Before Landing Checklist complete."
 - s. Decelerate toward 110 KIAS minimum after rolling out on final. Maintain 110 KIAS minimum on final until commencing the landing transition. Make an ICS call IAW local procedures.
 - t. Unless directed by the IP, power will remain at 4-6% throughout the flare to simulate a feathered prop. Anticipate longer flare and touchdown due to decreased drag. ***During simulated engine failure training, if touchdown will occur past the first 1/3 of the runway, WAVEOFF.***
4. **Common Errors.**
- a. Not getting the aircraft into a ***trimmed*** 125 KIAS glide speed.
 - b. Failure to compare actual and desired position and energy.
 - c. Improper position at high key (aircraft not aligned).
 - d. Excessive or insufficient bank angle at high key resulting in improper low key spacing.

- e. Premature configuration. For example, TO flaps lowered at low key with insufficient energy on profile.
- f. Not trimming throughout the ELP profile.
- g. Failure to anticipate or correct for wind.

706. EMERGENCY VOICE REPORTS

Emergency voice reports will be made in the *IDENTIFICATION, SITUATION, POSITION, AND INTENTION* (ISPI) format.

In a non-radar environment (VFR, squawking 1200, and not in communications with RDO), emergency reports of an immediate or serious nature are preceded by the word "MAYDAY." Repeating MAYDAY three times is the widely accepted method of clearing the frequency for an emergency voice report. An example of an emergency voice report in a non-radar environment is as follows:

"MAYDAY! MAYDAY! MAYDAY! [Call sign], engine failure, approximately 8 miles southeast of Evergreen at 2,500 feet, executing a controlled ejection between Castleberry and five lakes area."

In a radar environment (Radar Contact), or positive radio contact with a tower/RDO, standard procedure for a distressed or urgent situation is to declare an emergency. An example of an emergency voice report in a radar environment or positive radio contact with a tower/RDO is as follows:

"[Call sign] is declaring an emergency. Chip light, 5 miles east of Brewton at 4,500 feet. Executing a Precautionary Emergency Landing at Brewton."

Time permitting, expect to inform ATC/Tower/RDO of fuel remaining in hours and minutes (i.e., 1+00) and the number of people on board after delivery of ISPI information.

THIS PAGE INTENTIONALLY LEFT BLANK

CHAPTER EIGHT

SOLO FLIGHT

800. INTRODUCTION

For most students, the First Safe for Solo Checkride will be the most demanding task undertaken to date in their aviation career. While the safe-for-solo check is certainly challenging, successful completion is a rewarding, confidence-building experience.

801. THE SOLO FLIGHT

1. Preflight Preparation

- a. **Physical preparation.** Make sure your body is well rested. The average sleep requirement is eight hours during each 24-hour period. However, needs will vary with each individual. Lack of sleep means a lack of awareness. You should have learned your procedures throughout your training so do not try to "cram" the night before your flight. Get a good night's rest. If you have received your training properly, all that is necessary to prepare for the check flight is a review. Make sure that your body is well nourished. If you eat a well-balanced diet regularly, you will have a sufficient energy supply. Do not depend on a coffee and donut breakfast, or a coke and candy bar lunch. As always, avoid self-medication, and if you are sick, do not hesitate to see the flight surgeon. If you are ill, you do not belong in a cockpit.
- b. **Mental Preparation.** You must know your Standard Operating and Emergency Procedures before the flight. Since you have passed your check flight, you have demonstrated that you can safely operate the aircraft without assistance. However, you must be even more prepared for the solo, as there will not be an instructor to bail you out of critical situations. Study those procedures, especially those requiring immediate action. Prior to the solo, plan your flight in order to make efficient use of the limited time available. Review the course rules for the area in which you plan to operate. Pay particular attention to location of airfields that may be used in the event of an emergency. You should also ensure that you have the proper flight equipment and checklists in your possession. Prior to leaving the Flight Duty Officer's (FDO)/Operations Duty Officer's (ODO) desk, you should find out which OLF's are available for solo operations, their status and operating hours. Ask the FDO/ODO if he has any information that may pertain to your flight. And if you have any final questions, do not hesitate to ask.
- c. **Ground Procedures.** You will be assigned an aircraft for which you are solely responsible after signing the "A" sheet. Inspect all the gripes on the aircraft carefully. Once again, if you have any questions, do not be afraid to ask. Take note of any repeat gripes of a serious nature. Do not accept the aircraft for flight if there are any outstanding gripes which must be corrected.

- d. **Preflight.** Conduct a thorough and complete preflight. If you note any discrepancies, call a troubleshooter. Do not just ask a lineman. He is not qualified to make any judgments as to airworthiness. If any doubt exists, check with a flight instructor.
 - e. **Securing the rear cockpit.** Ensure the rear cockpit is secured for solo flight in accordance with the T-6B NATOPS Flight Manual. Again, if you have any questions, ask an instructor or call for a qualified maintenance person to assist.
 - f. **Start, taxi, and checks.** It is recommended that you read the checklists out loud as if your instructor were with you. This will reduce your chances of omitting an item on the checklist. While taxiing, keep your head "on a swivel." You are solely responsible for the safety of the aircraft and a good "See-and-Avoid" doctrine is imperative, both on the ground and in the air. You also need to pay attention to radio transmissions, especially those that begin with your call sign. If problems should arise, do not hesitate to ask the FDO/ODO for assistance.
2. **Takeoff and Flight.** Prior to taking the active runway, ensure you have clearance to do so. Read back the appropriate response as required. Even before this, you should have already thought out the Takeoff and Departure procedures to ensure a smooth evolution.
- a. **Restrictions.** You may not make a full-stop landing at an OLF unless directed by the RDO, or if weather or an emergency makes it necessary. If you must make a full-stop landing at an OLF, remember that you are responsible for the aircraft until either you return it to home field, or you are relieved of responsibility by a maintenance or instructor pilot. Perform Before Leaving the Aircraft checklist. Once you have properly taken care of your aircraft, call the FDO/ODO and advise him of your situation.

Solos may not practice spins, stalls, simulated engine failures, PPELs, or any maneuver which has not been previously introduced. Solo launch time is no earlier than sunrise with an RDO on station. Solo recovery is no later than 30 minutes prior to official sunset.
 - b. **High work.** Conform to local course rules and remain oriented. Check between maneuvers to see where you are in the working area and continue to do OPS checks. You should be monitoring the area common frequency, as well as the guard frequency in the event of a solo recall. Take time to practice maneuvers which you need to perfect. Keep your scan moving outside for other aircraft in the same operating area.
 - c. **Operations at Outlying Fields.** Ensure that you know the radio frequency and pattern altitude of the OLF you are about to enter. Utilize the proper entry and communications procedures for the OLF. Know the proper pattern direction and use extra care in establishing interval. You should also keep track of your flight time and number of landings accomplished at the OLF. When it is time to depart, follow applicable course rules and check your gear and flaps are in the "up" position.

- d. **Emergencies.** In all emergencies, the first consideration is to fly the aircraft. Then, determine the situation and your course of action in accordance with the T-6B NATOPS Flight Manual. When time permits, communicate and let others know your situation.
- i. **Lost aircraft.** If you get lost, admit it and try to communicate using all available channels and navigation aids including the nearest function on the Flight Management System (FMS). Land at a suitable airfield before you run out of gas. The best policy is to remain oriented and do not get lost. If you actually get lost, it will be necessary for you to use your own initiative and good judgment. Every situation will be different; therefore, it is impossible to establish a criterion that will apply to every set of circumstances. However, the following items, known as the five "Cs" will generally apply: **CONFESS, CLIMB, COMMUNICATE, CONSERVE, AND COMPLY.**
- (a). **CONFESS** - Admit that you are lost and need some form of assistance.
- (b). **CLIMB** - Ceiling and visibility permitting, climb to improve radio reception and forward visibility.
- (c). **COMMUNICATE** - Request assistance on the area working frequency from an instructor pilot or advice from your FDO/ODO. If unable, try calling Approach Control and request vectors to home field. If you get no reply, switch to GUARD and try again.

If ATC replies, they will ask you to squawk a certain code on your transponder. They may also ask you to provide other information in order to give you a vector (heading) to home field. If it appears that clouds will be on your vectored flight path, advise Approach and circle while maintaining VFR.

- (d). **CONSERVE** - Operate the aircraft (when straight and level) at maximum endurance AOA of 8.8 units. (150 KIAS)
- (e). **COMPLY** - With instructions received from another dual aircraft, ATC, or your base. Many prominent landmarks are available in and around your working areas, they may give clues as to your general whereabouts. If you find yourself lost, the important thing to remember is this: Do not fly about aimlessly. Be calm and develop a plan using your good judgment and established procedures. If you still cannot identify your position after having gone through the five "Cs," look for any established landing field. Before landing at a strange field, circle it at a safe altitude and locate all obstacles and hazards. Determine the wind direction and duty runway and try to get a rough estimation of runway length and width. If there is a tower at the field, try to contact Approach or Tower on GUARD prior to landing. Once you are ready to land, make a normal traffic pattern.

Remember that the field elevation may be considerably different from that of your home field. Use your best estimation and adjust accordingly. Once on deck, notify your base of the situation.

- ii. **Lost communications.** Should you experience lost communications, you may just have one bad channel. Try calling tower, ground, approach, or area common. Also, try setting in the manual frequencies. Attempt communication on the UHF, VHF and Back-up VHF. If this fails, use the lost communication procedures as described in the SOP. Remember, YOU are responsible for safe separation, so watch for other aircraft and remain VFR. Be sure to make all voice reports in the blind and rock your wings approaching the break. On final, double-check the Before Landing Checklist complete and for a green light from the tower. Know what all of the light signals mean as they can and will be given to you. Make a full-stop landing and clear the duty runway when safe.
 - iii. **PEL.** Should a PEL be necessary, execute one without hesitation at the nearest suitable field.
 - iv. **Emergency orbit pattern (Delta pattern).** Be familiar with the procedures for the emergency orbit pattern in accordance with local course rules. Once established in the pattern, you may contact the FDO/ODO and ask for assistance if needed. Follow the T-6B NATOPS Flight manual procedures as required.
 - v. **Unintentional Instrument Flight.** Instrument conditions are to be avoided at all times in Contact. If actual instrument flight is encountered, immediately level your wings on the attitude gyro and time for 30 seconds. If not VFR at the end of 30 seconds, attempt to regain visual flight conditions by making a shallow turn for 180°. If still not VMC, squawk 7700 and contact ATC for assistance (using 243.0 guard if necessary).
3. **Conclusion.** Lastly, enjoy your solo. This is your hop and it is designed to give you confidence in yourself and your abilities. Know and use the standard operating procedures that you have been taught. This hop will be a valuable and enjoyable step towards your becoming a competent Naval Aviator.

CHAPTER NINE AEROBATICS

900. INTRODUCTION

Aerobatics is any intentional maneuver involving an abrupt change in aircraft's attitude, intentionally performed spins, or other maneuvers requiring pitch/dive angles greater than 45°, bank angles greater than 60°, or accelerations greater than two Gs.

You will be receiving training on the Anti-G straining maneuver (AGSM) and the physiological effects of increased G loads. Review the aircraft G limits.

Refer to Figure 9-1 for aerobatic maneuver configuration parameters.

Aerobatic Maneuver	Entry Airspeed	Gs Required	Altitude Change	Exit Airspeed	Energy Classification	Power
Loop	230 – 250	High	NC	230 – 250	Neutral	MAX
Wingover	200 – 220	Low	NC	200 – 220	Neutral	~70%
Barrel Roll	200 – 220	Mod	NC	N/A	Neutral	~80%
Aileron Roll	180 – 220	Low	NC	N/A	Loser	~80%
Split S	120 – 140	High	- 3000 feet	< 250	Neutral	Idle-80%
Cuban Eight	230 – 250	High	NC	230 – 250	Neutral	MAX
Immelmann	230 – 250	High	+ 3000 feet	Flying A/S	Gainer	MAX
Cloverleaf	200 – 220	High	NC	200 - 220	Neutral	MAX

Figure 9-1 Aerobatic Maneuver Parameters

Prior to performing aerobatic maneuvers, complete the Pre-Stalling, Spinning, and Aerobatic Checks per the NATOPS PCL and accomplish clearing turns. For the clearing turns, use a minimum of 45° AOB and turn for a minimum of 180°. Throughout the turn, thoroughly check the area for other aircraft.

Start your aerobatic maneuvers from an altitude which will permit a complete maneuver and a return to straight and level flight at or above 6000 feet AGL. You must not exceed the maximum altitude permitted for your operating area. The maneuvers performed require approximately 3000 feet vertically.

901. RULES AND PRECAUTIONS FOR AEROBATIC FLIGHT

Due to their unique nature, there are certain rules and precautions you must observe prior to performing any aerobatic maneuver. Flight Rules and Regulations (FRR) and local SOP will prescribe restrictions governing the airspace within which you may perform aerobatic maneuvers. Ensure that you are thoroughly familiar with these regulations. Strict compliance is mandatory.

902. SECTION LINES AND GROUND REFERENCE POINTS

The maneuver descriptions and procedures of the various aerobatic maneuvers often refer to section lines and ground reference points. Understanding how to select and use these geographical references will greatly enhance your ability to remain oriented during the various aerobatic maneuvers.

Much of the area you will fly over is rural farm land or beachline/waterways. The lines which separate one "section" of land from another is called a "section line." These lines commonly run north/south or east/west in long, straight lines and are easily identified from the air. During the various maneuvers, these section lines are utilized as a reference to maintain directional control. Since some maneuvers involve a reversal in the direction of flight, it becomes necessary to select a line which extends both in front of and behind you. Highways, utility cuts or even beachlines may also be utilized, provided they are linear and of sufficient length.

Maneuvers such as the Barrel Roll or Wingover require the use of a ground reference point which is 90° from your initial heading. Ensure that the points which you select are prominent and easily seen, remembering that you will have to relocate them rapidly as you are passing through unusual attitudes. The rate at which you must scan while performing the maneuvers does not allow the time to search for a hard-to-see reference point. It is permissible to perform aerobatics "on top" of a cloud layer without the use of ground references. Use compass headings and altitudes for alignment. Care must be taken to stay within a designated working area.

903. CLEARING TURNS

During aerobatic flight, attitude, altitude and direction of flight change rapidly. You must therefore exercise extreme caution by ensuring the immediate area is clear of other aircraft and that no danger of midair collision exists. A clearing turn, as the name implies, allows you to clear the area in which you are operating. Use a minimum of 45° angle of bank and turn for a minimum of 180° of heading change. Two 90° turns in opposite directions will suffice. The direction of the last clearing turn shall be in the direction in which the maneuver will be performed. Throughout the turn, check the area thoroughly for other aircraft. Continue the turn until you have the desired airspeed and sufficient ground references to maintain orientation during the maneuver. Remember 180° of turn is a minimum, not an absolute. One clearing turn and Pre-Stalling, Spinning, and Aerobatic Checklist may suffice for a series of aerobatic maneuvers.

If the number of section lines or ground references is limited, then a teardrop maneuver is an effective means of performing the clearing turn while positioning the aircraft for the next maneuver. This may be performed by turning to place the nose approximately 45° from the section line, timing for 7-10 seconds, and then turning back to the reciprocal of the original heading.

Common Errors

- a. Failure to plan or execute the clearing turn(s) so that the chosen ground references are properly positioned to allow for adequate orientation during the subsequent maneuver.
- b. Not "clearing" the area sufficiently during the turn.
- c. Poor basic airwork during the clearing turn(s), resulting in the aircraft not being at the correct altitude and/or airspeed to commence the planned maneuver in a timely fashion.
- d. Failure to execute the maneuver within the cleared airspace.

904. G-INDUCED LOSS OF CONSCIOUSNESS

G-induced loss of consciousness (G-LOC) is a fainting episode caused by gravity-induced physiological stresses on the human body. The most commonly experienced G-forces are encountered by pilots during positive acceleration maneuvers (such as pulling out of a dive or turning at high angles of bank). This type of positive G-force (+Gs) is directed from head to foot, and therefore imparts a feeling of being pressed into the seat.

The ultimate effect of these forces on the human body is a tendency for blood to pool both in the lower abdomen and the extremities. This pooling effect dramatically reduces the volume of blood available to the eyes and brain, thereby critically reducing the oxygen available to sustain vision and conscious brain function. The typical G-LOC sequence of progression is as follows:

- a. Grayout — peripheral vision is progressively impaired.
- b. Blackout — vision is lost completely.
- c. Loss of consciousness.

Once G-LOC occurs, it typically lasts from 15-30 seconds. Once consciousness is regained, the individual usually exhibits a period of uncontrolled muscle spasms followed by disorientation or a "dream-like" state which can last from a few seconds to several minutes. Some pilots have described post G-LOC feelings of detachment, apathy and temporal distortion. Amnesia of the entire episode is a common occurrence. Impairment of piloting skills may last for *as long as 30 minutes*.

Navy and Air Force investigators have identified G-LOC as a probable causal factor in numerous Class A mishaps. The Air Force estimates that at least 12% of all Strike pilots have experienced actual G-LOC at least once. G-loading capability in the T-6B is comparable to most tactical jets, and therefore can easily cause G-LOC among the inexperienced or unprepared pilot.

Most T-6B G-LOC episodes occur during rapid G-loading of 3 to 5 G's over 2 to 5 second intervals. Pilots can prepare themselves for the physical stress of rapid accelerations and therefore prevent G-LOC by taking certain precautions:

1. Learn and use the proper Anti-G Straining Maneuver (AGSM), more commonly called the "HICK Maneuver." There are two components to the recommended AGSM:
 - a. The first component is a continuous and maximum contraction (if necessary) of all skeletal muscles including the arms, legs, chest, and abdominal muscles. This tensing of the skeletal muscles restricts blood flow in the G-dependent areas of the body and thereby assists in the retention of blood in the thoracic region (including the heart) and the brain.
 - b. The second component of the AGSM involves repeated closing of the respiratory tract at 2.5 to 3.0-second intervals. Its purpose is to counter the downward G force by expanding the lungs and increasing the chest pressure, thereby forcing blood to flow from the heart to the brain.

The respiratory tract is an open breathing system which starts at the nose and mouth and ends deep in the lungs. It can be completely closed off at several different points, the most effective of which is the glottis. Closing the glottis (which is located behind the "Adam's Apple") yields the highest increase of chest pressure. The glottis can be closed off by saying the word "HICK" and catching it about $\frac{3}{4}$ of the way through the word ("Hiii-"). This should be done after a deep inspiration, followed by forcefully closing the glottis as you say "HICK." Bear down for 2.5 to 3.0 seconds, then rapidly exhale by finishing the word HICK ("-ka"). This is immediately followed by the next deep inhalation, repeating the cycle until the G-loading is discontinued.

The exhalation and inhalation phase should last for no more than 0.5 to 1.0 second. Since the blood pressure falls dramatically during this phase, its duration must be kept to a minimum.

WARNING

Do not hold your respiratory straining too long (more than five seconds) since this will prevent the blood from returning to the heart properly and may result in loss of consciousness.

Anticipate the onset of high G forces whenever possible. Skeletal muscles should be tensed prior to the onset, coupled with the "HICK" respiratory cycle as the G-loading increases. Initiating the AGSM too early can inhibit the body's natural cardiovascular reflex responses, while beginning too late creates a deficit situation which may be difficult to overcome.

NOTE

If properly performed, the AGSM should provide adequate protection against G-LOC while performing the various aerobic maneuvers. If you experience difficulty, or are in doubt as to

whether or not you are executing the maneuver correctly, see your squadron flight surgeon or wing Aeromedical Safety Officer.

2. Inter-cockpit communication between aircrew is imperative. Both individuals must rely on the other not to apply high G forces without first giving prior warning. Historically poor crew communication has been a major causal factor in G-LOC episodes. During high G maneuvers, G-suit inflation can inadvertently key the radio transmit switch on the PCL. Take care to position your leg to prevent this from occurring and blocking communications with your IP.
3. Be prepared physically.
 - a. Avoid flying if ill or extremely fatigued.
 - b. Maintain an adequate fluid intake and do not skip meals.
 - c. Stay in shape. The optimum fitness program for increasing G-tolerance is a combination of moderate weight training and cardiovascular aerobic exercise (running, walking, swimming, etc.) 2-3 times weekly. Avoid excessive long distance running (more than 25 miles per week) or overly intense weight training. These will typically result in lower blood pressure and heart rate which may decrease G-tolerance.
4. G awareness Exercise/G warm-up maneuver: Accomplish a G-awareness exercise on sorties that include maneuvers that require or may result in 3 or more Gs. This may be accomplished by performing the following procedures:
 - a. Complete the Pre-Stalling, Spinning, and Aerobic Checklist. Notify the other crewmember that you are going to commence the G-awareness Exercise.
 - b. Begin wings level at 200-220 KIAS. Advance power to MAX, smoothly roll to 70-80 degrees AOB, allowing the nose to drop slightly below the horizon (no more than 10 degrees), pause momentarily to stop roll and smoothly pull.
 - c. The G-onset rate should be slow and smooth, allowing sufficient time to evaluate the effectiveness of the AGSM and determine G-tolerance. Increase Gs to approximately 4 Gs for approximately 4 to 5 breathing cycles in order to allow full cardiovascular response.
 - d. For advanced aerobatic and formation training, the G-awareness exercise should be flown to G-loads of 4 - 5 Gs.

905. CONTACT UNUSUAL ATTITUDES

1. **Description.** Recovery may be required due to an improperly flown maneuver, disorientation, area boundaries (lateral or vertical), an aircraft malfunction, or traffic conflicts.

2. **General.** The diverse and demanding missions performed by military aircraft often require maneuvers which involve unusual attitudes. An effective military pilot must therefore be trained to quickly recognize and then safely recover from unusual attitudes. This must often be accomplished while relying almost exclusively upon the interpretation of visual cues from outside the cockpit. In this stage of training you will perform the procedures for recovery from various unusual attitudes utilizing what is primarily a scan of visual references located outside the cockpit.

- a. The IP will configure the aircraft commensurate with entering an aerobatic maneuver of choice. Refer to Figure 9-1.
- b. The instructor will then smoothly maneuver the aircraft so as to place it in an unusual attitude.
- c. Once directed by the instructor, assume the controls and recover the aircraft in accordance with the following procedures. Recovery shall be accomplished by 6000 feet AGL.

Nose-High Recovery

A nose-high attitude can be encountered with insufficient airspeed to continue the maneuver. Immediate and proper recovery procedures prevent aggravated stall and spin. Expeditious return to level flight from a nose-high attitude, without departing controlled flight or exceeding aircraft limits.

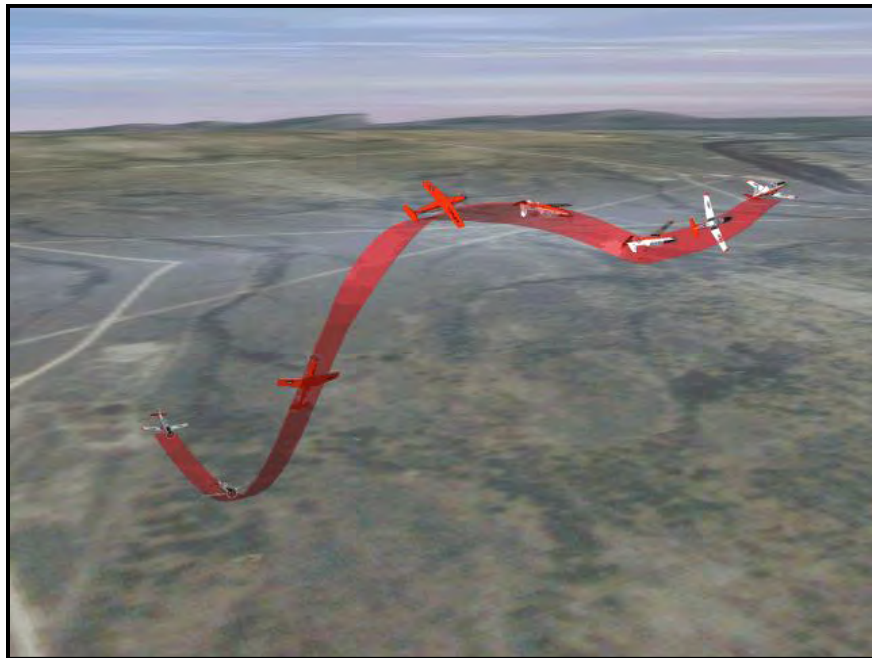

Figure 9-2 Nose-High Recovery

3. Procedures.

- a. Set power to MAX (as required in low airspeed situations) and initiate a coordinated roll *past 90° AOB*. Utilize back stick pressure to bring the nose of the aircraft down to the nearest horizon. Depending on initial airspeed and aircraft attitude, a wings-level, inverted attitude may be reached. As the nose approaches the horizon, roll to an upright attitude (Figure 9-2).

NOTE

Do not push the stick forward and induce zero or negative G in an effort to nose the plane back to the horizon.

NOTE

Only rolling to 90° AOB and knife-edging to the horizon should be avoided as it relies primarily on gravity to bring the nose to the horizon. This will not produce as expeditious of a recovery as rolling past 90° AOB and using positive G.

- b. If the airspeed is low, the rollout may be delayed until the nose is definitely below the horizon. In some cases, the nose has to be flown well below the horizon to regain enough airspeed to feel positive pressure on the controls. When airspeed is sufficient, roll wings level, raise the nose, check for normal oil pressure, and use power as required to recover to level flight.
- c. Do not be too aggressive when pulling to the horizon or pulling up from a nose-low attitude. The stick shaker and airframe buffet indicate a potential for stall. Decrease back-stick pressure before the stall.
- d. In all cases, observe system limitations when operating near zero-G.
- e. During some nose-high, low airspeed situations, when the aircraft responds to inputs slowly due to low airspeed or torque effect, a reduction in power may be required (usually below 60% torque) and all available control authority may be required to smoothly return the aircraft to level flight. If the aircraft does not respond normally, or if situational awareness is lost, an OCF recovery shall be accomplished.

4. Common Errors.

- a. Failure to set power to MAX (as required in low airspeed situations).
- b. Pushing the nose over (resulting in 0 or (-) G's)."
- c. Failure to roll past 90° AOB, resulting in an inability to use backpressure to bring the nose to the horizon.

Nose-Low Recovery.

Aerobatics require nose-low attitudes. Immediate and proper recovery procedures prevent a high-speed dive or excessive G-forces. Expeditious recovery to level flight from a nose-low attitude with minimum altitude loss and without exceeding aircraft limits.

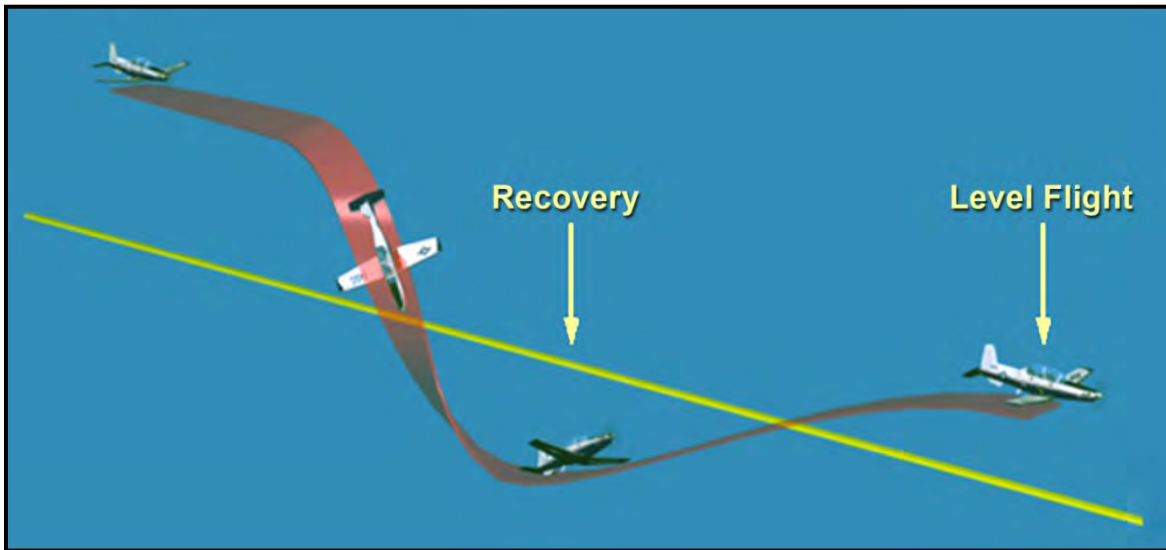

Figure 9-3 Nose-Low Recovery

5. Procedures.

Roll the aircraft to the nearest horizon while simultaneously reducing the PCL to IDLE. Use the speed brake as required. Do not exceed maximum allowable airspeed (316 KIAS). Airspeed may continue to increase as the nose is raised, and maximum airspeed can occur just before level flight is attained. G-loading increases during recovery. Accomplish a proper AGSM. With the nose on or slightly above the horizon, check oil pressure is normal then set power as required (Figure 9-3).

6. Common Errors.

Not reducing power and extending speed brake to prevent excessive airspeed.

Inverted Recovery.

Immediate and proper recovery procedures prevent a high-speed dive or excessive G-forces. Expeditious recovery to level flight from an inverted attitude with minimum altitude loss and without exceeding aircraft limits.

7. Procedures.

- a. When slightly nose-high, nose-low, or near an inverted position, recover by rolling in the shortest direction to set the aircraft in an upright position adding power as required. With the nose on or slightly above the horizon, check oil pressure is normal then power as required.
- b. For purely inverted recoveries, execute a coordinated roll to the nearest horizon.

8. Common Errors.

Not rolling in shortest direction to horizon.

906. LOOP

1. **Description.** The loop is a 360° turn in the vertical plane with constant heading and nose track. Because it is executed in a single plane, the elevator is the principle control surface. Ailerons and rudder are used to maintain directional control and coordinated flight. The maneuver is complete when wings are level at the horizon on the same heading as at entry.

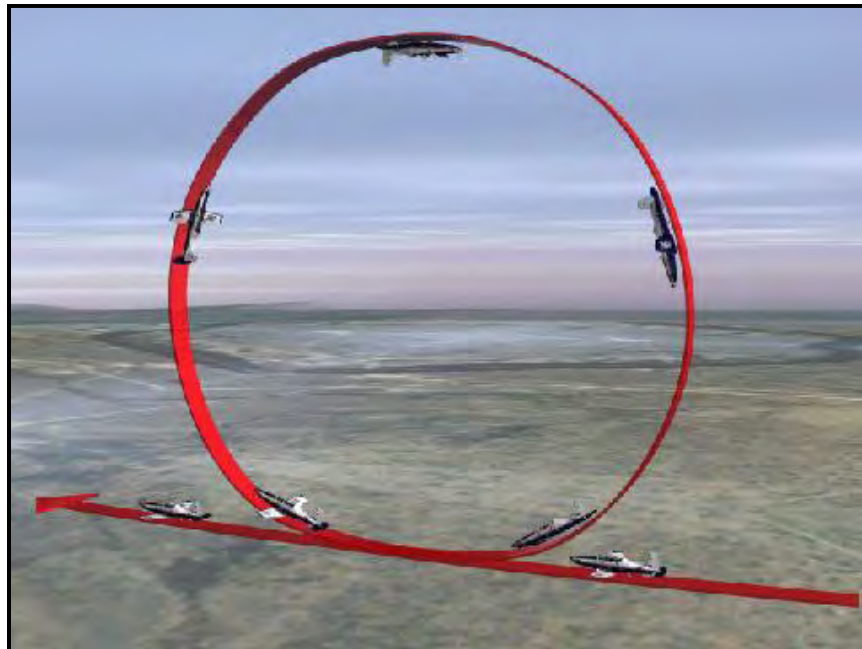

Figure 9-4 Loop

2. **General.** The Loop is one of the most rudimentary aerobatic maneuvers, yet one which requires skill and practice to consistently perform well. The nose pitch rate should be constant, but the aft stick force required to obtain this will vary with airspeed and "G" loading. Directional control is maintained by adjusting rudder input as the airspeed varies, thereby maintaining balanced flight. Aileron is used only in making corrections to maintain the wings parallel with the horizon throughout the entire maneuver.

3. Procedures.

- a. **CONFIGURATION:** Entry airspeed 230-250 KIAS, power at MAX.
CHECKLIST: Complete the Pre-Stalling, Spinning and Aerobatic Checklist.
CLEAR AREA: Clear working area with visual scan, TCAS, and clearing turns as required.
- b. Recheck the wings level and clear the airspace above you. Just prior to entry, check and report the entry altitude over the ICS. Commence the AGSM and immediately start a smooth straight pull up accelerating to 4 Gs within two to three seconds. Do not use the aileron.
- c. Recheck the wings level as the nose passes through the horizon. Adjust stick pressure as necessary to keep the nose moving at a constant rate. Increase right rudder pressure as airspeed decreases.
- d. Shortly after passing the vertical position, tilt your head back and visually locate the opposite horizon. Correct with aileron as necessary to maintain the wings parallel to the horizon. Check the nose in relation to the section line and correct directional deviations as necessary by adjusting the rudder input.
- e. Airspeed will reach its slowest point at the top of the Loop (100-120 KIAS). The greatest amount of right rudder input will therefore be required at this point in order to maintain balanced flight. The amount of aft stick force required to maintain a constant nose pitch rate will have decreased significantly from the initial pull-up. Maintain positive "G" loading and wings parallel to the horizon.
- f. Allow the nose to fall through the opposite horizon, adjusting the amount of aft stick pressure to maintain a constant pitch rate. Fly the aircraft's nose along the section line, relaxing right rudder pressure as airspeed is quickly regained.
- g. Continue to relax right rudder pressure as the airspeed increases in the dive and smoothly increase aft stick pressure as necessary to maintain a constant pitch rate. The recovery will again require approximately 4 Gs, so remember to resume the AGSM.

4. Common Errors.

- a. Failure to check and report the altitude prior to entry. It is hard to recover on the altitude you began the maneuver when you do not know what it is.
- b. Poor directional control caused by failure to maintain balanced flight with the proper amount of right rudder as airspeed is lost and then regained. Poor rudder control is easily detected by checking the alignment of the nose and the section line. Remember that the required rudder input varies as airspeed varies. Almost constant rudder adjustment will be required during the maneuver.

- c. Poor directional control caused by failure to keep the wings parallel to the horizon throughout the maneuver. The most common tendency by far is to pull the stick slightly to the right when pulling the nose up during the 4 G entry. Keep the stick centered longitudinally as the entry input is made. Check and correct the wing attitude often.
- d. Poor execution of the initial pull-up with respect to G-loading and/or timing. Remember, 4 Gs in two to three seconds. Scan the accelerometer. Excessive G-loading and/or loading the aircraft too quickly will cause an excessively rapid deceleration, and may result in overstress. Insufficient G-loading, or taking too long to obtain the correct acceleration, will deplete the aircraft's energy state, resulting in a stalled or near-stalled condition when approaching the inverted position.
- e. Relaxing too much back-stick pressure while passing through the inverted position at the top of the Loop. This will result in a "floating" sensation. Remember to maintain some positive G-loading throughout the entire maneuver. Conversely, failure to relax sufficient back-stick pressure over the top will result in excessive angle of attack and stick shakers. If this occurs, relax the back-stick pressure slightly.
- f. Failure to initiate the pull-out soon enough during the second half of the Loop. This results in excessive airspeed and recovery below the initial altitude.

907. WINGOVER

1. **Description.** The Wingover is a 180° reversal in the direction of flight accomplished by combining a smooth climbing turn for 90° with a smooth diving turn for 90°. Recovery should be on the same altitude and approximately the same airspeed at which the maneuver was started.

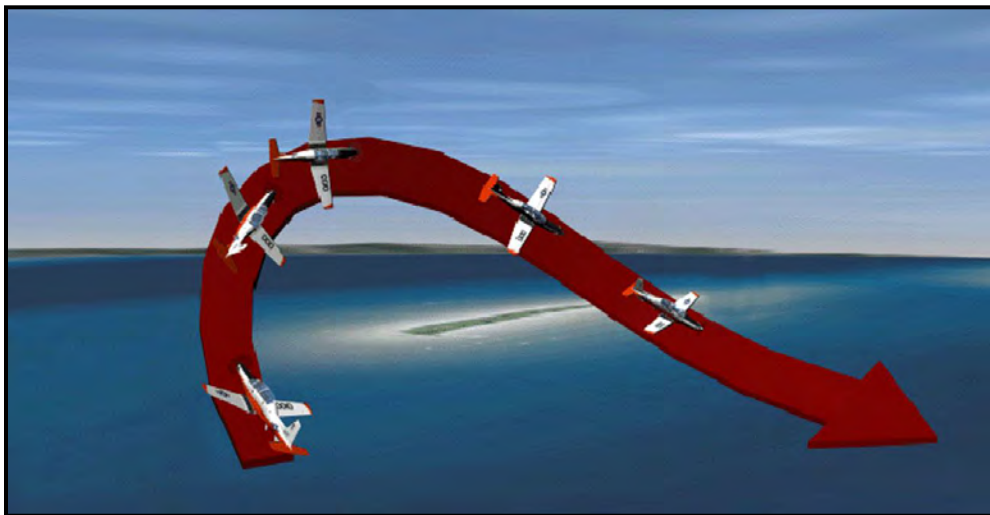

Figure 9-5 Wingover

2. **General.** The Wingover will develop your ability to smoothly control the aircraft in balanced flight through constantly changing attitudes and airspeeds. It is a slow and gentle

maneuver when properly executed. No abrupt control movements are necessary. The maneuver may be initiated in either direction and is always performed in a series of two. You should therefore complete the series on the same heading that the first Wingover was initiated. Flying the maneuver in series will enable you to develop a "feel" for the changing control pressures and the rhythm of the maneuver. Successive Wingovers, when continued without interruption, serve as clearing turns for the next series.

When your instructor first demonstrates the Wingover, it is of primary importance that you acquire a mental picture of the path through which the aircraft is flying. Notice the appearance of the nose and the wings in relation to the ground and the horizon at various points during the maneuver. Once you are able to visualize this, the Wingover is merely a matter of flying the aircraft in balanced flight through this pattern. Since you are learning to fly the aircraft in a predetermined pattern, keep your scan primarily outside of the cockpit. Use your instruments only for an occasional reference to crosscheck your sensory impressions.

The rate of roll should be constant throughout the maneuver. The nose should always move at a constant rate in relation to the horizon as it describes arcs, first above and then below the horizon. Remember that in turns to the right, torque and slipstream effect must be offset with a greater amount of rudder input than in turns to the left. Proper performance of the maneuver demands smooth coordination of control pressures to maintain balanced flight. The rate of pitch and roll during the Wingover is relatively slow, therefore the resultant increased G-loading is relatively slight. It should not be necessary to exceed 2.0 Gs at any time during the maneuver.

3. **Procedures.**

- a. **CONFIGURATION:** Entry airspeed 200-220 KIAS. Set power to ~70%

CHECKLIST: Complete the Pre-Stalling, Spinning and Aerobatic Checklist.

CLEAR AREA: Clear working area with visual scan, TCAS, and clearing turns as required.

- b. Begin in straight-and-level flight, with briefed entry airspeed and power setting. Select the desired reference point on the horizon or ground, and align the aircraft so the reference point is directly off a wingtip. Blend aileron, rudder, and elevator pressures simultaneously to start a gradual climbing turn in the direction of the reference point. If turn rate and pitch rate are the same, it will be difficult to obtain 45 degrees nose up. The initial bank should be very shallow to prevent excessive turn rate. As the nose is raised, the airspeed decreases, causing the rate of turn to increase. Time the turn and pull-up so the nose reaches the highest pitch attitude (approximately 45°) when the aircraft has turned 45° or halfway to the reference point. Use outside references and the attitude indicator to crosscheck these pitch-and-bank attitudes. Bank continues to increase as the nose falls. The aircraft should be pointed at the reference point as a maximum bank of 90° is reached and the nose reaches the horizon. The lowest airspeed occurs just as the nose reaches the horizon.

- c. Do not freeze the pitch or bank at the horizon. Passing the horizon, let the nose fall, and begin rolling out of bank. The second half of the leaf (nose below horizon) should be symmetric and approximately the same size as the first half (nose above the horizon). The bank should change at the same rate as during the nose up portion of the leaf. When the aircraft has turned 135° , the nose should be at its lowest attitude and the bank should be 45° . Continue blending control stick and rudder pressure to simultaneously raise the nose and level the wings. Monitor the progress of the turn by checking the outside reference point (off opposite shoulder from maneuver start). The aircraft should be wings level at entry airspeed as the nose reaches the horizon, having completed 180° of turn.
- d. Without delay, begin the second leaf in the opposite direction of the first. Repeat steps b and c.
- e. Upon completion of the series, the aircraft should once again be established in level balanced flight, on the original heading and altitude.

NOTE

Set up perpendicular to a long road or section line. Visualize the road as the straight line part of a dollar sign (\$). The two turns of the maneuver complete the "S" portion of the dollar sign. If ground references are unavailable, the heading bug can be set to the initial heading and used to monitor the progress of the turns.

During the nose up part of turns, pull to put the bottom foot (foot on inside of turn) on top of the horizon and roll around it until reaching approximately 60° bank.

When bringing the nose back to the horizon from a nose-low attitude, the number of knots below wings level airspeed should be approximately equal to the number of degrees nose-low. For example, if the wings desired level airspeed is 220 knots, the airspeed should be approximately 190 knots at 30° nose-low, 200 knots at 20° nose-low, etc.

4. Common Errors.

- a. Rushing the maneuver. Remember, the Wingover is a relatively slow and finesse maneuver.
- b. Failure to obtain 45° nose up and 45° AOB simultaneously. This is usually caused by an excessive roll rate and/or insufficient back-stick pressure during the initial pull-up. Once the AOB exceeds 45° , it is difficult to raise the nose any higher. This type of error will result in excessive airspeed at the 90° checkpoint. As the aircraft rolls, smoothly increase the back-stick pressure so as to obtain 45° nose up simultaneously with 45° AOB. The required back-stick pressure reaches a maximum at approximately this point. You must then continue to roll towards the 90° checkpoint

- at a constant rate while beginning to relax the back-stick pressure. By the time you reach 90° AOB you should only have enough back-stick to keep from feeling light in your seat (i.e., slight positive G-loading).
- c. Exceeding 90° AOB.
 - d. Holding excessive back-stick pressure at the 90° checkpoint, thereby "pulling" the nose through and obtaining the reciprocal heading too early during the recovery. Conversely, releasing all of the back-stick pressure, thereby inducing a zero or negative G state.
 - e. Poor timing of the roll and pitch rate during recovery. The wings should come level simultaneously as the nose reaches the level flight attitude.
 - f. Commencing the second Wingover in the series off airspeed, heading, altitude, etc.

908. BARREL ROLL

1. **Description.** A barrel roll is a maneuver in which the aircraft is rolled 360° about an imaginary point which bears 45° off the nose of the aircraft (Figure 9-6). Definite seat pressure should be felt throughout the roll. Practice in both directions.

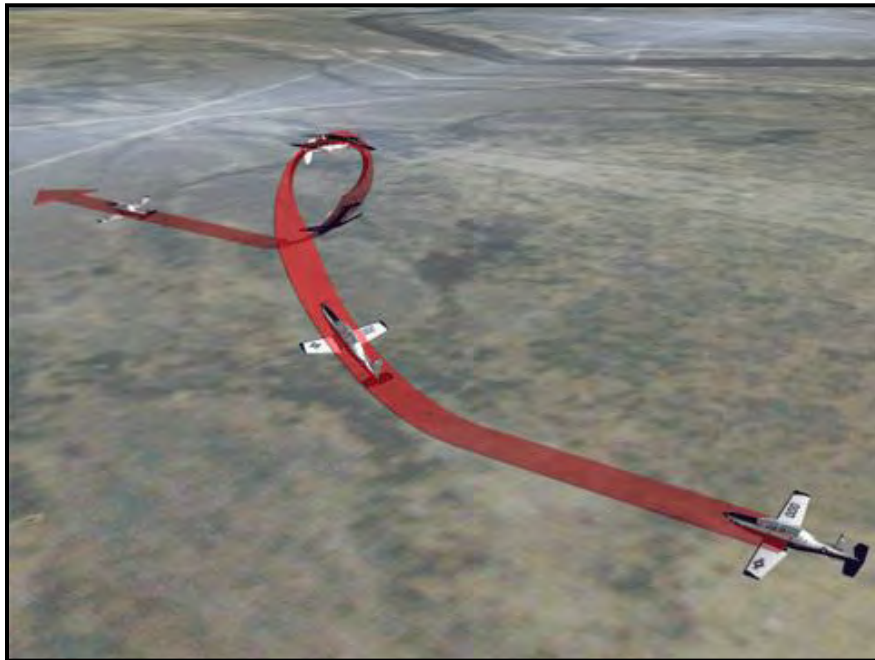

Figure 9-6 Barrel Roll

2. **General.** The Barrel Roll will help develop your confidence, coordination and "sense of feel" while flying the aircraft through rapidly changing attitudes and airspeeds. Since attitude, heading, and airspeed change so rapidly, this is an excellent maneuver for developing your ability to maintain orientation.

3. Procedures.

- a. **CONFIGURATION:** Entry airspeed 200-220 KIAS. Set power to ~80%.

CHECKLIST: Complete the Pre-Stalling, Spinning and Aerobatic Checklist.

CLEAR AREA: Clear working area with visual scan, TCAS, and clearing turns as required.

- b. Recheck the wings level and clear the airspace above you. Just prior to entry, check and report the entry altitude over the ICS. Commence the maneuver by smoothly raising the nose while keeping the wings level. As the nose passes ~20° above the horizon, roll and pull so that the nose travels around in an arcing path towards the selected 90° checkpoint. After 45° of turn, the angle of bank should be 90° and the nose will be at its highest point during the maneuver (approximately 55-60° above the horizon).
- c. Continue rolling the aircraft at a constant rate until in a wings level, inverted attitude, heading directly at the 90° reference point on the horizon. Your nose should be slightly above the horizon, airspeed 100-120 KIAS. Fly the aircraft through the inverted position and continue rolling at a constant rate, completing the maneuver on the original heading and altitude. Maintain a positive "G" load throughout; 2.5 Gs should not be exceeded at any time. If properly performed, the second half of the maneuver should be symmetric and approximately the same size as the first half.
- d. The nose should appear to make an arcing path about the imaginary point on the horizon 45° from your original heading. The last half of the arc will, therefore, be the same distance below the horizon that the first half is above the horizon. Remember, as the airspeed decreases towards the top of the maneuver, it will be necessary to increase the deflection of the ailerons, rudder, and elevator to maintain a constant rate of pitch and roll. Conversely, as the airspeed increases towards the bottom of the maneuver it will be necessary to decrease the deflection of the ailerons, rudder, and elevator to maintain a constant rate of pitch and roll. Notice that this roll is started as a climbing turn, which then becomes a continuous roll at a constant rate.
- e. Maintain orientation throughout the maneuver by concentrating on your reference points. Maintain a constant rate of roll and nose movement. Inscribing a small arc above the horizon in the first half of the maneuver and a larger arc below the horizon in the last half will result in too great an airspeed at the completion of the maneuver or unnecessarily high "G" forces to recover on airspeed. During the roll out to the original heading, adjusting the back-stick pressure will enable you to recover on altitude and at aerobatic cruise airspeed.

4. Common Errors.

- a. Failure to raise the nose high enough during the first 45° of turn. Generally, this will result in a correspondingly nose low attitude and proportionally high airspeed when recovery is made.
- b. Improperly coordinating the rate of roll with the rate of pitch. An insufficient roll rate will result in an overshoot of the intended recovery heading while an excessive roll rate will result in an undershoot. A common tendency is to allow the roll rate to accelerate after passing the inverted position.
- c. Failure to maintain balanced flight. Too much or too little rudder will produce essentially the same results as too fast or too slow a rate of roll, respectively.
- d. Failing to scan ahead for the reference point and/or section line and thereby losing orientation.
- e. Student not looking outside enough, attempting to execute Instrument Barrel Roll.
- f. Failure to get the nose far enough below the horizon on the backside resulting in being high and slow upon completion of maneuver.

909. AILERON ROLL

1. **Description.** The aileron roll is a 360° roll about the longitudinal axis of the aircraft. The maneuver is complete when the wings are parallel to the horizon.



Figure 9-7 Aileron Roll

2. **General.** Plan your clearing turn so as to roll out on a good section line or with the nose aimed at a prominent reference point. When performing the maneuver make your control inputs smooth, brisk and positive.

3. Procedures.

- a. **CONFIGURATION:** Entry airspeed 180-220 KIAS. Set power to ~80%.

CHECKLIST: Complete the Pre-Stalling, Spinning and Aerobatic Checklist.

CLEAR AREA: Clear working area with visual scan, TCAS, and clearing turns as required.

- b. Smoothly raise the nose to ~10° nose-high pitch attitude. Relax back-stick pressure and stop nose track, then roll the aircraft left or right using aileron
- c. As the aircraft approaches wings level, neutralize the aileron, and return to level flight.

4. Common Errors.

- a. Failure to relax the back-stick pressure prior to rolling. Back-stick pressure is required only to set the initial nose attitude. Failure to relax the back-stick pressure will cause the nose to follow an arcing path rather than having the aircraft roll about its longitudinal axis. It will also cause the nose to drop rapidly while passing the inverted position.
- b. Delaying initiation of the roll once the nose high attitude is set. This causes excessive airspeed decay, which results in a sluggish roll performance.

910. SPLIT-S

1. **Description.** The split-S combines the first half of an aileron roll with the last half of a loop. The aircraft climbs during entry and descends during recovery. The maneuver is complete when the aircraft returns to level flight.

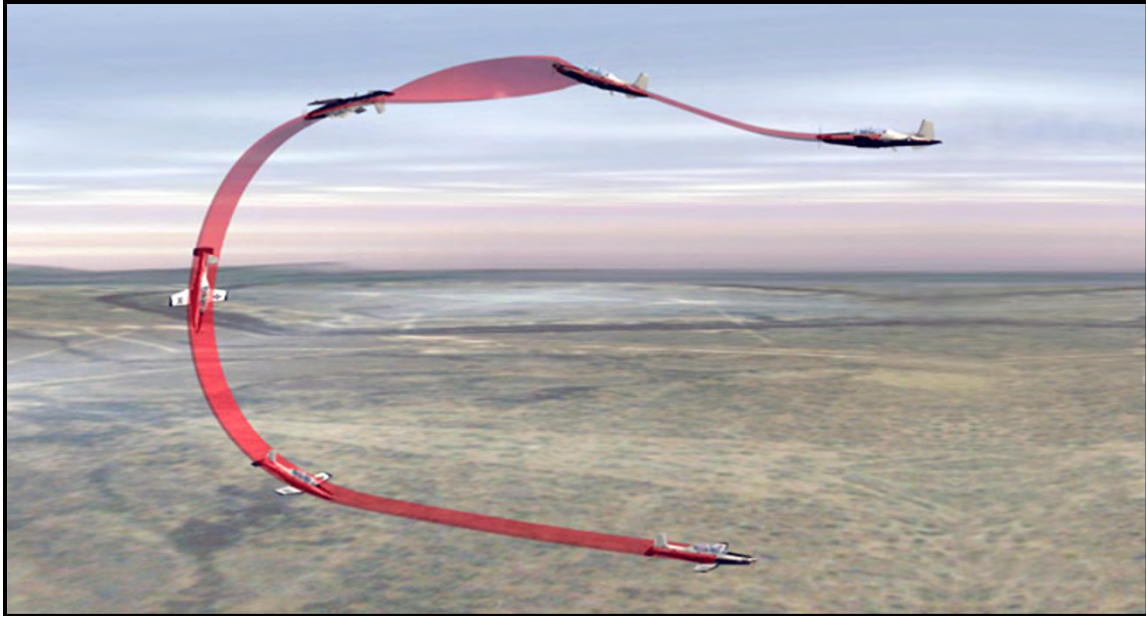

Figure 9-8 Split-S

NOTE

Student solos are strictly prohibited from performing the Split-S, Immelmann, Cloverleaf, Combination Maneuver, and intentional sustained inverted flight maneuvers. Failure to comply with this safety related restriction is considered sufficient grounds for attrition from flight training.

2. **General.** The Split-S provides a means of rapidly converting the potential energy of altitude into airspeed while reversing the direction of flight. Once the pull is commenced from the inverted position, airspeed builds rapidly and altitude is quickly lost. If performed correctly, the altitude loss should be approximately 3000 feet. Remember to select a long, well defined section line which extends behind as well as in front of you.

3. **Procedures.**

- a. **CONFIGURATION:** Transition to 150 KIAS.

CHECKLIST: Complete the Pre-Stalling, Spinning and Aerobatic Checklist.

CLEAR AREA: Clear working area with visual scan, TCAS, and clearing turns as required.

- b. Reduce power to idle and maintain altitude while slowing to 140 KIAS.
- c. Raise the nose to an approximately $\sim 10^\circ$ pitch attitude.

- d. Roll the aircraft to the wings-level, inverted attitude. Once inverted, neutralize the ailerons. Quickly verify that the wings are level by referencing the horizon and correct as necessary.
- e. Apply backpressure to bring the nose through the horizon. Attempt to achieve maximum nose track, without stalling.
- f. Airspeed and G-loading (approximately 4 Gs) increase during the pullout.
- g. Perform a proper AGSM.
- h. Once back to level flight, check oil pressure within normal limits. Report the oil pressure over the ICS and reset power as required.

NOTE

Like the loop, attempt to set up the maneuver over a road or section line. Ensure wings are level inverted before starting pull. Looking at successive points above the canopy bow (as described on the back half of the loop) that lead in a straight line from below the aircraft out to the horizon can also help ensure a straight pull.

4. Common Errors.

- a. Failure to maintain altitude and/or balanced flight during the deceleration.
- b. Delaying roll initiation, airspeed decay causes difficult lateral control.
- c. Failure to obtain, check and/or correct wings level prior to the pull-out. This results in disorientation and a rolling pull-out.
- d. Pulling too much back-stick before sufficient airspeed has been gained resulting in a near-stalled AOA.

911. CUBAN EIGHT

1. **Description.** Each half of this maneuver is a combination of a slightly modified loop and Immelman. The first portion of each leaf is approximately the first five-eighths of a loop followed by a half roll. The pull and roll is then repeated in the opposite direction. The maneuver looks like an 8 on its side. The maneuver is complete at level flight, with entry airspeed and on original heading.

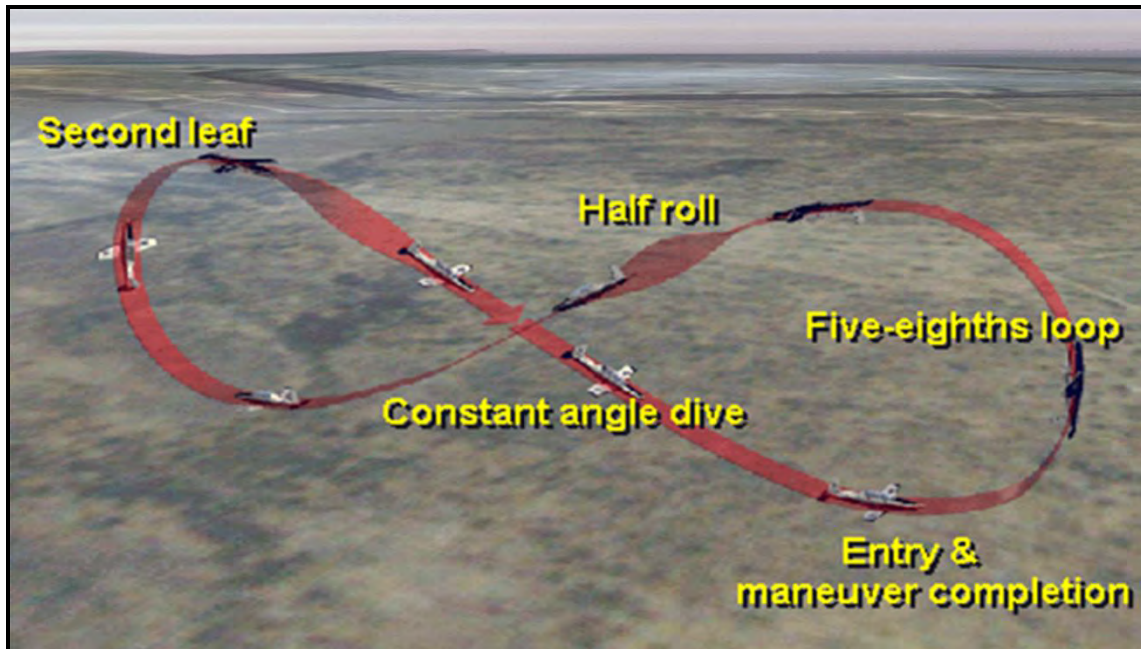

Figure 9-9 Cuban Eight

2. **General.** Remember to select a long, well defined section line which extends behind as well as in front of you.
3. **Procedures.**
 - a. **CONFIGURATION:** Entry airspeed 230-250 KIAS. Set power to MAX.
CHECKLIST: Complete the Pre-Stalling, Spinning and Aerobatic Checklist.
CLEAR AREA: Clear working area with visual scan, TCAS, and clearing turns as required.
During the last 90° of turn, lower the nose slightly and accelerate to 230-250 KIAS.
 - b. Recheck the wings level and clear the airspace above you. Just prior to entry, check and report the entry altitude over the ICS. Commence the AGSM and immediately start a smooth straight pull-up, accelerating to 4Gs within two to three seconds. Do not use the aileron.
 - c. Recheck the wings level as the nose passes through the horizon. Adjust stick pressure as necessary to keep the nose moving at a constant rate. Increase right rudder pressure as airspeed decreases.

- d. Shortly after passing the vertical position, tilt your head back and visually locate the opposite horizon. Correct with aileron as necessary to maintain the wings parallel to the horizon. Check the nose in relation to the section line and correct directional deviations as necessary by adjusting the rudder input.
- e. Airspeed will reach its slowest point at the top of the modified loop (100-120 KIAS). The greatest amount of right rudder input will therefore be required at this point in order to maintain balanced flight. The amount of aft stick force required to maintain a constant nose pitch rate will have decreased significantly from the initial pull-up. Maintain positive G-loading and wings parallel to the horizon.
- f. Allow the nose to fall through the opposite horizon, adjusting the amount of aft stick pressure to maintain a constant pitch rate. As the nose approaches a point 45° below the opposite horizon, slow the nose movement by releasing back-stick pressure and commence a roll in either direction. During the roll, it will take slight forward stick pressure as the aircraft passes wings vertical to hold the heading and allow the nose to continue pitching downward to a position 45° below the horizon.
- g. After completing the half roll, maintain 45° nose-low until beginning the pull up for the second half of the maneuver. Plan to initiate the pull up to attain briefed entry airspeed at the horizon (passing through level flight). Begin the pull-up at approximately 205 to 210 KIAS (airspeed lead point approximately equal to number of degrees of nose-low pitch). Continue the pull-up into another loop entry. The second half of the Cuban-8 is identical to the first except the roll is in the opposite direction.

NOTE

Use ground references, or heading bug, as in other over the top maneuvers. Upon reaching 45° nose-low inverted (seat on the horizon), momentarily freeze the control stick before the coordinated roll. To maintain 45° nose-low, pick a point on the ground and freeze it in the windscreen.

4. Common Errors.

- a. Same common errors as the first half of a Loop.
- b. Improper forward stick application during roll resulting in less than the desired 45° nose down attitude.

912. IMMELMANN

1. **Description.** The Immelmann is a half loop followed by a half roll, all flown in the same vertical plane. The maneuver is complete after a momentary pause in level flight with wings level on an opposite heading from entry.

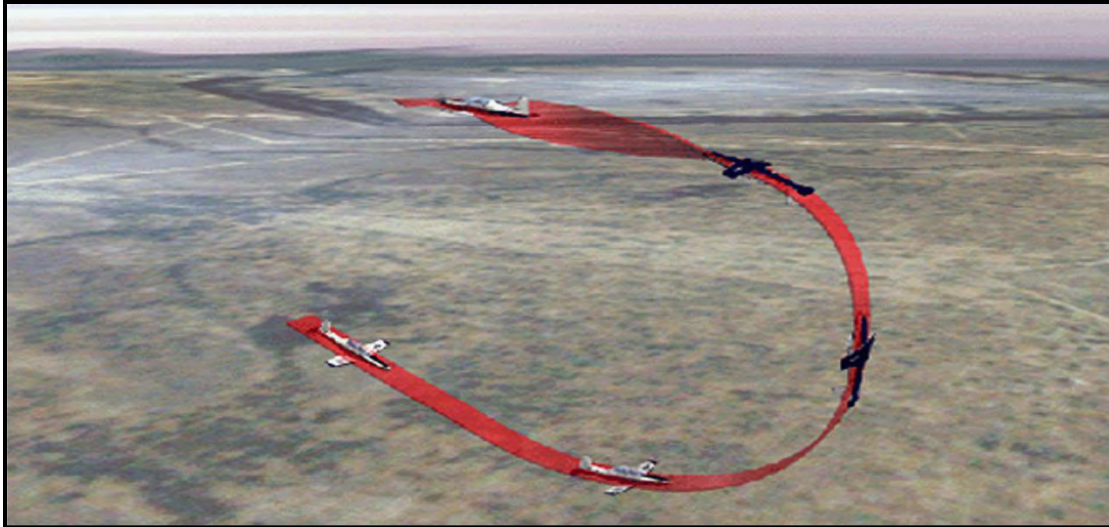

Figure 9-10 Immelmann

2. **General.** This maneuver offers a quick means of reversing the direction of flight while trading excess airspeed for increased altitude. Remember to select a long, well defined section line which extends behind as well as in front of you.

3. **Procedures.**

- a. **CONFIGURATION:** Entry airspeed 230-250 KIAS. Set power to MAX.

CHECKLIST: Complete the Pre-Stalling, Spinning and Aerobatic Checklist.

CLEAR AREA: Clear working area with visual scan, TCAS, and clearing turns as required.

- b. Lower the nose slightly and accelerate to 230-250 KIAS.
- c. Recheck the wings level and clear the airspace above you. Just prior to entry, check and report the entry altitude over the ICS. Commence the AGSM and immediately start a smooth straight pull-up, accelerating to 4 Gs within 2-3 seconds. Do not use the aileron.
- d. Recheck the wings level as the nose passes through the horizon. Adjust stick pressure as necessary to keep the nose moving at a constant rate. Increase right rudder pressure as airspeed decreases.
- e. Shortly after passing the vertical position, tilt your head back and visually locate the opposite horizon. Correct with aileron as necessary to maintain the wings parallel to the horizon. Check the nose in relation to the section line and correct directional deviations as necessary by adjusting the rudder input.

- f. As the nose approaches a point $\sim 10^\circ$ above the opposite horizon ("FCP canopy bow" on the horizon), slow the rate of nose movement by neutralizing back-stick pressure. Commence a roll in either direction to the upright position. Anticipate the need for slight forward stick pressure as the aircraft passes 90° of roll.
- g. The maneuver is complete when the aircraft is once again in the level flight attitude on the reciprocal heading. The airspeed should be approximately 120 KIAS. The nose attitude will therefore be slightly high.

4. Common Errors.

- a. Same common errors as the first half of a Loop.
- b. Commencing the roll to upright attitude either too early or too late.
- c. Utilizing improper rudder and/or poorly coordinated rudder inputs during the roll.

913. CLOVERLEAF

1. **Description.** The cloverleaf is composed of four identical maneuvers, each of which changes heading by 90° . The pull up is similar to the loop, although with less G-load. The top part is a rolling pull to the horizon 90° displaced from the original heading. The pulling roll resembles a nose-high recovery. The lower part or pull through is flown like a split-S. The maneuver is complete in level flight after four leaves in the same direction. Fewer than four leaves may be performed when practicing the maneuver.

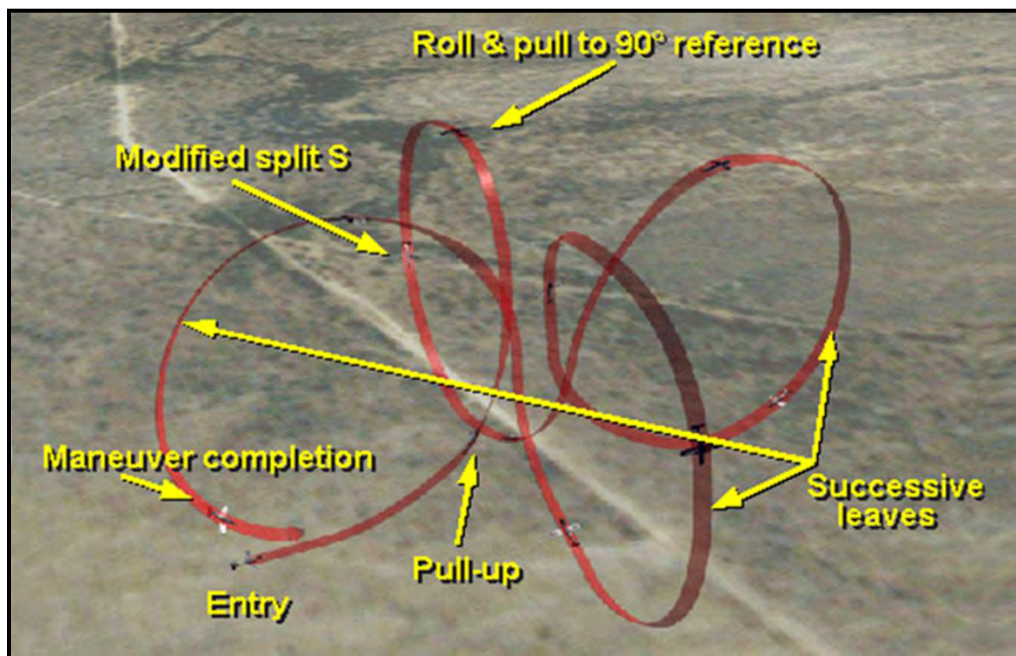

Figure 9-11 Cloverleaf

2. **General.** Combine elements of the loop, roll, and split-S into a fluid maneuver.
3. **Procedures.**
 - a. **CONFIGURATION:** Entry airspeed 200-220 KIAS. Set power to MAX.
CHECKLIST: Complete the Pre-Stalling, Spinning and Aerobatic Checklist.
CLEAR AREA: Clear working area with visual scan, TCAS, and clearing turns as required.
 - b. Begin in straight-and-level flight, with briefed entry airspeed and power setting. Pick a reference point 90° off the nose in the desired direction. The initial part of the maneuver is a straight pullup similar to a loop except for a slightly lower G-loading (2-3 Gs).
 - c. As the aircraft reaches 45° nose-high (feet on the horizon), begin a coordinated roll toward the 90° reference point. Allow the nose to continue climbing during the roll so the maneuver is fairly slow and lazy.
 - d. Coordinate the pull and roll so the nose passes through the reference point with the aircraft wings level, inverted, and at a relatively low airspeed (100-120 KIAS). Do not stare at the airspeed indicator, but note the airspeed at the inverted point. Keep the wings level and pull through the bottom of the maneuver as in the split-S. To avoid excessive G and airspeed at the bottom, attempt to MAX perform (as in the split-S) once the nose passes the horizon.
 - e. Approaching the horizon in the pull through, reduce back pressure to allow acceleration to entry airspeed at the horizon. Complete three additional leaves in the same direction.

NOTE

Use section lines or prominent roads off of the wingtip in the direction of turn to visually identify 90° points. Begin roll when your feet are on the horizon. A combination of roll and pull is necessary to be inverted wings level over the reference point. Crosscheck G-load at horizon after each pull though the bottom. Reaching 200-220 knots at the horizon, G-loading may then have to be reduced to the 2-3 Gs required for the initial pull up by releasing back-stick pressure.

4. **Common Errors.**

Getting disorientated in the maneuver.

914. COMBINATION MANEUVER

1. **Description.** A Combination Maneuver is nothing more than combining a series of aerobatic maneuvers into a single evolution. A maximum of **FOUR** maneuvers may be "linked" together.

2. **General.** The aerobatic training you receive is NOT intended to prepare you for the air show circuit. As previously discussed, aerobatic training IS taught to allow you to make the aircraft perform precise and controlled maneuvers, flying the aircraft throughout more of its envelope.

By combining maneuvers, you will need to plan ahead to the second maneuver while completing the first half. As always, maintain a constant and vigilant scan, especially during the maneuvers.

Energy management should be a part of the discussion so as to plan maneuvers to maximize airspeed/altitude, while staying within assigned airspace. This should be a major consideration for which maneuvers are linked together and in what order.

Example: Loop - Cuban Eight - Immelmann - Split-S

3. **Procedures.** Perform all maneuvers IAW the procedures previously set forth for the maneuvers you intend to fly. The SNA shall pre-plan his/her Combination Maneuvers and thoroughly brief his/her intentions to the IP before execution.

915. INVERTED FLIGHT

1. **Description.** The Inverted Flight maneuver is the intentional flying of the T-6B in the inverted wings level attitude for a maximum of 15 seconds. Review T-6B NATOPS Flight Manual regarding inverted flight.

2. **General.**

It is imperative that you tighten your restraint harness to the maximum extent possible (without cutting off your circulation). Regardless of how tight you think your belts are, once inverted, you will have the sensation of being pulled from the aircraft. Notice the nose attitude. The T-6B requires a relatively high nose attitude in order to maintain level flight.

Reference points that may be used to keep the aircraft from changing altitude while inverted are:

- a. Front Cockpit = prop arc on the horizon.
- b. Rear Cockpit = intersection of rear canopy bow and canopy rail on the horizon

Monitor the oil pressure and clock to remain within limits. Ensure the rudder pedals are within reach in this attitude.

3. Procedures.

- a. **CONFIGURATION:** Entry airspeed 180-200 KIAS.

CHECKLIST: Complete the Pre-Stalling, Spinning and Aerobatic Checklist.

CLEAR AREA: Clear working area with visual scan, TCAS, and clearing turns as required.

- b. Raise the nose to an approximately $\sim 10^\circ$ pitch attitude, stop the nose movement by relaxing back-stick pressure.
- c. Roll the aircraft to the wings-level, inverted attitude. Once inverted, neutralize the ailerons and apply enough forward stick pressure to maintain altitude. Immediately note the clock and check oil pressure. Return to normal flight immediately if oil pressure is not in the normal range.
- d. Prior to 15 seconds inverted, use coordinated aileron and rudder to roll the aircraft back to the upright flight attitude. Recheck the oil pressure in the normal range.

4. Common Errors.

- a. Failure to maintain straight-and-level flight while inverted.
- b. Poor coordination of control inputs during the roll to the inverted and/or upright positions.

CHAPTER TEN ANGLE OF ATTACK APPROACHES

1000. INTRODUCTION

This chapter contains procedures to conduct Angle of Attack (AOA) approaches. The AOA approach is typically used by carrier based airplanes to perform a precision approach to the carrier. The skills learned by conducting AOA approaches in the T-6B will be used as a building block for advanced jet training.

1001. ANGLE OF ATTACK APPROACHES

1. **Description.** The AOA approach is a descending 180° balanced turn to final followed by a normal flared landing. During the approach, the optimum AOA is maintained by controlling nose/pitch attitude and rate of descent is controlled by power adjustment.

2. **General.** You are introduced to angle of attack approaches for two primary reasons. One is to simply broaden your exposure to different aspects of aviation. Additionally, AOA approaches are commonplace in jet and multi-engine aircraft and are virtually mandatory when used with a visual glideslope indicator during carrier landings. Should you end up flying jets or multi-engine aircraft, your exposure to AOA approaches in the T-6B will be beneficial.

AOA is displayed on the PFD and AOA indexer. The PFD provides continuous AOA readout. When the gear is down, the indexer displays one or two of three illuminated symbols. Depending on which symbols are illuminated, the indexer tells you if you are flying at optimum, higher than optimum, or less than optimum AOA. Refer to the T-6B NATOPS Flight Manual for further discussion of the AOA system.

For a pattern with gear down, flaps LDG, and PCL set for a 3° glidepath, the optimum approach speed (center donut) is approximately 100 KIAS at maximum landing weight. As landing weight decreases, approach AOA (center donut) continues to provide the optimum approach speed and maneuver speed (regardless of bank angle). Optimum approach airspeed decreases approximately 1 knot for every 100 pounds of fuel burned.

The AOA system in the T-6B is calibrated in units of AOA, not degrees. An adjustment is automatically made to the readout based on whether the flaps are up, set to TO, or LDG. Because of this, optimum AOA is 10.5 units, regardless of configuration.

As you can see, flying an approach at optimum AOA gives you an adequate safety margin (approach airspeed above stall speed), while keeping your approach and landing speed low.

3. Procedures.

- a. AOA approaches will normally be flown after one or more touch-and-go landings. After a touch-and-go, climb out at 120 KIAS with the flaps up. Climb to pattern altitude.

- b. During the turn, notify other aircraft in the pattern that you are performing an AOA approach.
- c. Level off at pattern altitude at 120 KIAS. TRANSITION as follows:

No Flap AOA: Established on downwind, reduce power to 15-20% and slow to optimum AOA (~110 KIAS). Carefully adjust power to 25-30% to maintain pattern altitude and adjust nose attitude to maintain optimum AOA, an amber donut, "O" on the indexer. Maintain 10-11 units and a $\frac{3}{4}$ -1 wingtip distance on downwind.

TO Flap AOA: Established on downwind, reduce power to 15-20%, lower flaps to TO and slow to optimum AOA (~100 KIAS). Carefully adjust power to 25-30% to maintain pattern altitude and adjust nose attitude to maintain optimum AOA, an amber donut, "O" on the indexer. Maintain 10-11 units and a $\frac{3}{4}$ -1 wingtip distance on downwind.

LDG Flap AOA: Established on downwind, reduce power to 15-20%, lower flaps to LDG and slow to optimum AOA (~95 KIAS). Carefully adjust power to 25-30% to maintain pattern altitude and adjust nose attitude to maintain optimum AOA, an amber donut, "O" on the indexer. Maintain 10-11 units and a $\frac{3}{4}$ -1 wingtip distance on downwind.

- d. Perform the Before Landing Checklist prior to abeam position.
- e. At the 180° position, initiate final turn by reducing power to approximately 15-20%. Lower the nose slightly to maintain 10-11 units, commence the TURN and TALK. Your pattern over the ground should be the same as in previous landings. You may require less angle of bank with TO Flap/LDG Flap approaches. Using the same angle of bank as in a normal approach would result in too tight a turn.
- f. During the approach, scan the AOA indexer, the aimpoint and the altimeter. Adjust power and attitude as necessary to maintain the proper rate of descent and 10-11 units. If the green "slow" chevron ("V") lights up, your AOA is higher than optimum and your airspeed is too slow. To correct, lower the nose slightly. The chevron points in the direction the nose needs to go. Too low of a nose attitude results in illumination of the red "fast" chevron, indicating less than optimum AOA and excessive airspeed. In this case, the correct response is to raise the nose. Again, all nose attitude adjustments must be coordinated with power to control altitude/rate of descent.
- g. Rate of descent should be constant. Vary the angle of bank and power as necessary to arrive at the proper 90° position (10-11 units AOA, 450 feet AGL or $\frac{1}{2}$ the pattern altitude in feet AGL, perpendicular to the runway). Maintain 10-11 units AOA through the rest of the turn to final. When you are established on final with 1200-1500 feet of straightaway from the runway threshold, ensure 150-250 feet of altitude and maintain 10-11 units AOA until just prior to the runway threshold. On

short final, transition to a normal flared landing.

NOTE

The intent of this training is to do an AOA approach to a normal flared landing, not an AOA approach to an AOA landing!

4. Common Errors.

- a. Excessive nose attitude corrections. Scanning the indexer will indicate if you are not at optimum AOA. A glance at the gauge will show how far from optimum. Correct only as much as necessary.
- b. Failure to coordinate power and attitude changes. Keep in mind that power affects AOA attitude. Remember to control AOA with attitude and rate of descent with power.
- c. Using the same angle of bank as utilized during normal landing patterns.
- d. Failure to transition to a normal flared landing.

THIS PAGE INTENTIONALLY LEFT BLANK

CHAPTER ELEVEN NIGHT CONTACT

1100. INTRODUCTION

You are now ready to enter one of the most interesting stages of your flight training - NIGHT CONTACT. There is no reason for you to approach it with any more apprehension than you did the transition from day to night driving in an automobile. In fact, you will find much in common between the two experiences. Just as you did not try to drive at night until you had perfected your skill in handling an automobile in the daylight, you now come to night flying with an improved feel of the airplane and the ability to make your airplane do precisely what you want it to do. One of the greatest tactical advantages of Naval Aviation is our superior night operational capability. As a fleet Naval Aviator, a great percentage of your flying will be conducted at night.

Your first night flight is not intended to teach you all there is to know about night flying, but to familiarize you with the fundamentals. You will come to realize that there are differences in night flying, but that a careful study of these differences will make flying at night as safe as in the daytime.

Good night flying, like good night driving, requires increased care. You will have to identify obstructions and other aircraft, not by entire outline, but by such small identifying features as a few colored lights. This is not difficult if you leave the ground well prepared for the conditions you will meet, and if you remain constantly alert. Once you are in the air, clear of all ground obstructions, the only possible obstruction remaining will be other aircraft. Obviously it is essential that you know the location of other aircraft.

1101. NIGHT FLYING PHYSIOLOGY

1. **Night Vision.** You will remember from lectures on flight physiology that the eye uses different parts for night vision than for day vision. Because of the difference in function of the rods and cones, technique must be changed in order to spot objects at night: Do not stare at a spot, but scan the vicinity of the sky in which you believe the object to be located.

The eyes must be adapted for night vision; the pupils must dilate and the rods must be brought into full use. It takes approximately 30 minutes for the eyes to become completely adapted, and only 10 seconds for all adaptation to be lost in bright light. Adaptation may be accomplished by total darkness or by gradually approaching darkness such as normal daylight to sunset to night.

2. **Vertigo.** Vertigo, in aviation, is a feeling of dizziness and disorientation caused by doubt in visual interpretation of your attitude. This feeling is often experienced at night from lack of a well-defined horizon. The period immediately after takeoff, leaving a well-lighted runway and entering complete darkness, brings on this feeling of disorientation. Trust and use your flight instruments.

3. **Moving and Stationary Lights.** Often you will not be able to see anything of the aircraft ahead except its tail light or strobe lights. In such cases, it will be difficult to judge distance,

since the only criterion for judgment will be changing intensity at changing distance; therefore, you will have to check its movement in relation to known references to ascertain relative movement. Ordinarily, you can judge distance and relative motion by the distance between two lights on the same aircraft. You will undoubtedly experience some difficulty in discerning moving lights from fixed lights or stars. This can be further complicated by the autokinetic effect, the apparent motion of stationary objects. Again, this may be overcome by using known references for comparison.

1102. PERSONAL PREPARATION

Briefs for all night flights will be given prior to commencing syllabus night operations. Ensure that you eat a good meal prior to attending the brief. There are many times when the night's flight operations will be lengthy, so ensure that your body is properly fueled.

Students are expected to know Emergency procedures thoroughly prior to the brief and will be quizzed on them by the Instructor Pilot. If you are not absolutely certain about all Night procedures and Emergency procedures, make sure you are certain before you leave the briefing room.

In addition to the normal flight equipment required for day flight operations, the following equipment is required for all night flights:

1. Flashlight with clear and red lenses.
2. Clear visor installed in your helmet (prior to the brief).

1103. NIGHT GROUND PROCEDURES

This section provides the basic procedures essential to the safe operation of the airplane on the ground at night. These procedures cover night operations both before and after flight.

1104. PREFLIGHT PROCEDURES

The night preflight will include all items checked on day preflight with the following additions:

1. Check the operation of all interior lights in both cockpits during the cockpit check.
2. With the battery on, complete a check of all exterior lights. Conduct a walk-around of the aircraft to ensure operation of all exterior lights. Ensure any discrepancies are corrected prior to flight.

1105. LIGHT SIGNALS

The student must have a precise knowledge of all light signals to safely conduct night operations. The T-6B NATOPS Flight Manual contains the required ground handling signals.

11-2 NIGHT CONTACT

1106. START

The start will be accomplished in the same manner as daylight operations except that the NAV lights switch will be *on* and the ANTI-COLLISION (strobe) lights will be *off*. Cockpit lights will dim during start. When the pilot is ready for the start, he will signal the lineman by rotating the flashlight at the lineman or if ambient light permits, use appropriate hand signals for clearance to start. The lineman will repeat the signal with his wand or appropriate hand signal and will man the fire extinguisher for the start.

NOTE

In the line area, where adequate light is available, hand signals may be used as in daylight operations. However, when lighting is not adequate, hand signals must be passed as light signals (see the T-6B NATOPS Flight Manual for ground handling signals).

1107. TAXI

The Before Taxi Checklist shall be completed and clearance from Ground Control received prior to taxi in accordance with the T-6B NATOPS Flight Manual and local SOP. All taxiing will be conducted in accordance with current course rules. Caution must be exercised to prevent excessive taxi speeds caused by lack of outside references and depth perception. Landing/Taxi lights should be used during all night taxi evolutions in areas not adequately illuminated. Consideration will be given to courteous use of lights to avoid the disorientation of other aircraft, ground support, and tower personnel. Taxi is only permitted on lighted, authorized taxiways (see SOP). If there is any doubt as to your position on the field or any confusion caused by light signals, STOP! Do not continue until reoriented. Turn Landing/Taxi lights off while conducting the Overspeed Governor and Before Takeoff Checklists or if a delay is encountered at the hold short line awaiting takeoff.

1108. NIGHT FIELD LIGHTING

1. **BLUE LIGHTS:** Blue lights mark all taxiways. There should be blue lights on both sides of the taxiway.
2. **WHITE LIGHTS:** White lights mark the boundaries of the duty runway.
3. **GREEN LIGHTS:** Green lights mark the threshold of the duty runway.
4. **RED LIGHTS:** Red lights mark all obstructions on the airfield.
5. **ROTATING BEACON:** There is a rotating white and green beacon located at fields that are open for night operations. A military airfield's white light will be split by a 3° void. This will give the impression that there are two separate, closely timed flashes of light. A civilian airport has a solid white light and can be easily distinguished from a military field.

6. **TETRAHEDRON:** A wind tetrahedron points in the direction of the wind and is lighted with red lights along the left rear and side of the tetrahedron and green lights on the right rear, side and top of the tetrahedron.

7. **WIND TEE:** A lighted wind tee is located in the grass area immediately west of the control tower at NAS Corpus. The wind tee is free-swinging and outlined in green lights.

1109. OVERSPEED GOVERNOR CHECKLIST

Taxi to the appropriate runup area for the duty runway and night operations, (see current SOP). Complete the Overspeed Governor and Before Takeoff Checklist as in daytime operations. Taxi to the holdshort line in accordance with local course rules.

1110. INBOUND TAXI PROCEDURES

1. Landing traffic will turn off only on lighted taxiways (see current SOP for any exceptions).
2. When clear of the duty runway, switch to Ground Control and complete the After Landing Checklist (strobe lights will be turned off or IAW local SOP).
3. Make the appropriate call to Ground Control for taxi.
4. Taxi via the most direct route to the appropriate line. Inbound Taxi procedures are the same as Outbound Taxi procedures. See current SOP for inbound taxi routes.

1111. ENGINE SHUTDOWN

1. Engine shutdown will be conducted in accordance with the T-6B NATOPS Flight Manual and the current SOP.
2. The navigation lights will remain on until the propeller has come to a complete stop.

1112. POSTFLIGHT INSPECTION

1. All aircraft will be postflighted following each flight in accordance with the T-6B NATOPS Flight Manual.
2. Complete a thorough postflight inspection utilizing a white-lens flashlight.

1113. NIGHT CONTACT FLIGHT PROCEDURES

This section provides the basic procedures required to conduct night flight operations. While these procedures form a basis, the expanded procedures for each Training Air Wing may be varied. Consult your most current SOP for further amplification.

1114. TAKEOFF PROCEDURES

1. All takeoffs will be conducted in accordance with the T-6B NATOPS Flight Manual and the current SOP.
2. Call for takeoff clearance IAW local SOP/Course Rules.
3. Once takeoff clearance has been issued, position on the duty runway. Crossing the holdshort line, complete the Lineup Checklist. Position the aircraft on the runway centerline. Commence Takeoff procedures IAW daytime operations.

1115. HOMEFIELD DEPARTURE

Comply with tower instructions and make departure in accordance with local SOP.

1116. LANDING PATTERN

Entry to touch-and-go fields will be in accordance with the current SOP/Course Rules. Break procedures will remain the same as day operations. After the break or crosswind turn, roll out with a $\frac{3}{4}$ -1 wingtip distance on the downwind leg.

At night, the wingtip distance remains the same as in the day. Crosscheck the PFD for the reciprocal heading of the duty runway to assist in maintaining wingtip distance abeam. Crosscheck the attitude gyro to maintain wings level in the downwind leg.

Transition the same as daytime. At the 180° position, start the approach turn and make the appropriate radio call in accordance with local SOP. The approach and landing at night are the same as in the daytime. Your 90° position and final checkpoints remain the same. The Landing/Taxi lights will be used in accordance with local Course Rules.

Avoid fixating on the intended point of landing. A waveoff should be executed if you cannot touch down in the first one-third of the runway or if lined up extremely right or left of runway centerline.

Initiating the landing transition, smoothly and continuously reduce the PCL to idle and control your rate of descent with a smooth, continuous flare until touchdown. It is imperative that you focus on the end of the runway vice directly over the nose. "Spotting the deck" may result in a hard landing. Remember, at night, peripheral cues are greatly reduced requiring a continuous scan.

After touchdown on the main gear, smoothly lower the nose to the deck. Smoothly apply power to full forward; following engine spool-up, raise the nose to the takeoff attitude. Make a normal takeoff by maintaining directional control with rudders and climb out at 120 KIAS. Make heading corrections as necessary to maintain runway centerline as you proceed upwind. When the proper interval has been established and you are cleared downwind by the tower (at controlled fields only), you may begin your crosswind turn utilizing a maximum of 45° angle of

bank If the preceding aircraft is full-stop, wait until it is 45° behind the wingtip.

NOTE

Due to lack of ground reference points at night, attention should be given to the effects of crosswinds throughout the landing patterns.

1117. WAVEOFF

If you waveoff for any reason during an approach, execute the normal waveoff procedures. Waveoff procedures are the same as during day operation. Maintain 120 KIAS and climb IAW SOP/Course Rules. Turn downwind with proper interval (or as directed by the tower). If you are given a waveoff prior to the 180° position, make a waveoff in a racetrack pattern in accordance with local SOP. Fly up the side of the runway dictated by local Course Rules or as tower directs. Take interval in the pattern when you can safely do so. Remember, you are under tower control at homefield. If you are unable to comply with directions given by the tower, let them know.

It is mandatory to execute a waveoff under any of the following conditions:

1. Waveoff lights from the RDO or wheels watch.
2. Red light from the tower.
3. Verbal command from the IP, RDO, crash crew, or the tower.
4. No clearance received from the tower for a touch-and-go or full-stop landing.
5. Unable to touch down safely on the first one-third of runway.

It is the prerogative of the pilot to initiate a waveoff at any point in the approach when he/she feels uncomfortable.

1118. HOMEFIELD ARRIVALS

Refer to current SOP.

1119. HOMEFIELD BREAK

The Night Break procedures are basically the same as day procedures in accordance with local SOP.

1120. LANDING

Landing and rollout will be conducted the same as during daylight operations.

1121. NIGHT EMERGENCY PROCEDURES

The Emergency procedures for the T-6B are outlined in the T-6B NATOPS Flight Manual and the Pocket Checklist.

1122. VISUAL AIRCRAFT-TO-AIRCRAFT SIGNALS

In the event of lost communications, it is necessary to have standard visual aircraft-to-aircraft signals.

1. **"FOLLOW ME"** - If another aircraft joins on you, turns its external lights off and on several times, and then continues ahead of you, this means "follow me."
2. **"CONTINUE ON COURSE"** - While following another aircraft as described above, it turns its external lights off and on several times and breaks away sharply to the RIGHT, this means "continue on course."
3. **"ORBIT THIS POSITION"** - If the aircraft you are following turns its external lights on and off several times and then breaks sharply to the LEFT, this means "orbit this position." Establish an orbit and remain there until the aircraft again joins up and signals to follow.
4. **"I MUST LAND IMMEDIATELY"** - If it becomes necessary to make an immediate landing and you have no radios, signal to the aircraft that joins up with you by using your flashlight. With a lighted flashlight pointed directly towards the other aircraft, rotate the light in a circular motion similar to your signal to the lineman for start.

THIS PAGE INTENTIONALLY LEFT BLANK

**APPENDIX A
GLOSSARY OF TERMS**

A100. GLOSSARY - N/A

THIS PAGE INTENTIONALLY LEFT BLANK

APPENDIX B COMMUNICATIONS

B100. INTRODUCTION

Radio communications are a critical link in the air traffic control system. The link can be a strong bond between aircrew and controller, but it can be broken with surprising speed, leading to disastrous results. The most important aspect of aircrew-controller communications is understanding. The controller must understand what you want to do before he can properly carry out his control duties. Similarly, you must know exactly what he wants you to do. Although brevity is important, concise phraseology may not always be adequate. Use whatever words are necessary to state your message. It cannot be stressed enough that communication plays a vital role in the flight evolution. With experience, it should become second nature.

B101. COMMUNICATION

There are several things to consider when using aircraft radios:

- First, pause and listen before you transmit. If you hear others talking, the keying of your transmitter will be futile. You will probably jam the frequency, causing them to repeat their call. If you have changed frequencies, allow your receiver time to tune, then listen and make sure the frequency is clear before you begin your transmission. Also, do not transmit during an exchange between the controller and another aircraft. For example, if the controller asks another aircraft a question, you should wait until the other aircraft has answered before transmitting.
- Think before keying your transmitter. Know what you want to say. If it is a lengthy transmission such as a flight plan, write it down. Avoid saying "and" prior to each transmission.
- After your call, release the button and wait a few seconds before calling again. The controller may be jotting down your call sign, looking for your flight plan, transmitting on a different frequency, or switching his transmitter to your frequency.
- Be alert to the sounds, or lack of sounds, in your receiver. Check your volume and frequency setting. Check your equipment to ensure that your microphone is not stuck in the transmit position. Frequency blockage can, and has, occurred for extended periods of time because of unintentional transmitter operation. This situation is referred to as a "stuck mike." Avoid revealing your innermost thoughts during this time.
- Be sure that you are within the performance range of station equipment. UHF radios are limited to "line-of-sight" communications. Remember that as altitude increases, radio range increases. The approximate range of your radio can be determined by using the range chart located in the Meteorology section of your Flight Information Handbook (reproduced as Figure 1).

For example, an aircraft at 5000 feet will have an approximate radio range of 50 nautical miles to a ground station.

- Know what to expect. As you progress through each flight you should know what is expected to happen. In order to do this, you and controllers will make certain transmissions. If you know what is to be said ahead of time, responding correctly will be much easier. Use the proper formats and terminology to assist you in making brief and concise transmissions. Good phraseology enhances safety and is the mark of a true professional.

NOTE

Active ELT signals can interfere with normal communications. If an ELT is broadcasting on Guard, temporarily switch the UHF to "T/R" (vice "T/R +G"). Wait a few minutes and re-select "T/R +G." Repeat as necessary.

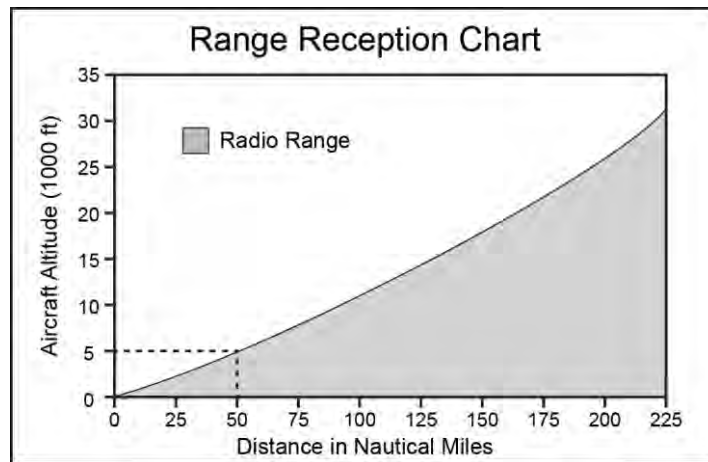

Figure B-1 Range Reception Chart

B102. CALL SIGNS

1. **Ground Station Call Signs.** When calling a ground station, you should begin with the name of the facility being called, followed by the type of facility being called; for example:

Clearance Delivery	"Clearance Delivery"
Ground Control	"North Ground," "Navy Corpus Ground"
Airport Traffic Control Tower	"North Tower," "Navy Corpus Tower"
Radar Departure Control	"Pensacola Departure," "Corpus Departure"
Radar or Nonradar Approach	"Pensacola Approach," "Corpus Approach"
FAA Air Route Traffic Control Center	"Jacksonville Center," "Houston Center"
FAA Flight Service Station (FSS)	"Pensacola Radio," "San Angelo Radio"
USAF Pilot to Metro Service (PMSV)	"Eglin Metro," "Kelly Metro"

B-2 COMMUNICATIONS

2. **Aircraft Call Signs.** Improper or abbreviated call signs can result in a pilot's executing a clearance intended for another aircraft. As an example, assume that a controller issues an approach clearance to an aircraft at the bottom of a holding stack and an aircraft with a similar call sign (at the top of the stack) acknowledges the clearance with the last two or three numbers of his call sign. If the aircraft at the bottom of the stack did not hear the clearance and failed to intervene, flight safety would be affected. This kind of "human" error can strike swiftly and is extremely difficult to rectify. You must be certain that aircraft identification is complete and clear before taking action on an ATC clearance. FAA personnel should not abbreviate call signs of aircraft having authorized call signs. FAA may initiate abbreviated call signs of other aircraft by using a prefix and the last three digits or letters of the aircraft identification after communications are established. Controllers, when aware of similar or identical call signs, will take action to minimize errors by emphasizing certain numbers or letters, by repeating the entire call sign, or by repeating the prefix.

B103. VERBALIZATION

1. Time

The 24-hour clock system is used in radio-telephone transmissions. The hour is indicated by the first two figures and the minutes by the last two figures. FAA uses Greenwich Mean Time (GMT), Coordinated Universal Time (UTC) or Zulu ("Z") for all operations.

Example: 0000 ZERO ZERO ZERO ZERO

Example: 0920 ZERO NINER TWO ZERO

Time may be stated in minutes only (two figures) in radio-telephone communications when no misunderstanding is likely to occur. When two figures are used, the current hour (within 60 minutes) is understood to be the time being referenced.

Example: "Mobile Radio, [Call sign], low-level, entering Victor Romeo One Zero Two Zero at Point Alpha at Four Three, exit Point Foxtrot."

"Four Three" is understood to mean 43 minutes past the current hour. If the call was made at 0935 local time, the aircraft will enter the low-level route at 0943 local.

Current time in use at a station is stated in the nearest quarter minute in order that pilots may use this information for time checks or to set their clocks. Fractions of quarter minutes less than eight seconds are stated as the preceding quarter minute; fractions of quarter minutes of eight seconds or more are stated as the succeeding quarter minute.

Example: 0929:05 TIME: ZERO NINER TWO NINER STRAIGHT UP 0929:10 TIME:
ZERO NINER TWO NINER AND ONE QUARTER

2. Figures

Digits indicating hundreds and thousands in round numbers, such as ceiling heights and upper wind levels up to 9999, shall be spoken as follows:

Example: 500 FIVE HUNDRED
4500 FOUR THOUSAND FIVE HUNDRED

Numbers above 9999 shall be spoken by separating the digits preceding the word "thousand."

Example: 10,000 ONE ZERO THOUSAND
13,400 ONE THREE THOUSAND FOUR HUNDRED

All other numbers shall be transmitted by pronouncing each digit.

Example: 10 ONE ZERO

When a radio frequency contains a decimal point, the decimal point is spoken as "point" or "decimal."

Example: 322.1 THREE TWO TWO POINT ONE
322.1 THREE TWO TWO DECIMAL ONE

3. Altitudes and Flight Levels

Up to but not including 18,000 feet MSL (FL180), state the separate digits of the thousands, plus the hundreds, if appropriate.

Example: 12,000 ONE TWO THOUSAND
12,500 ONE TWO THOUSAND FIVE HUNDRED

At and above 18,000 feet MSL (FL180), state the words "flight level" followed by the separate digits of the flight level.

Example: 19,000 FLIGHT LEVEL ONE NINER ZERO

Feet in MSL (Mean Sea Level) is understood in altitudes; therefore it is not necessary to say "feet."

4. Directions

State the three digits of all magnetic courses, bearings, headings, or wind directions. All are assumed to be magnetic. The word "true" must be added when it applies.

Example: (magnetic course) 005 ZERO ZERO FIVE
(true course) 050 ZERO FIVE ZERO TRUE

(magnetic bearing) 360 THREE SIX ZERO
 (magnetic heading) 100 ONE ZERO ZERO
 (wind direction) 220 TWO TWO ZERO

5. Speeds

State the separate digits of the speed followed by the word "knots." The controller may omit the "knots" when ordering a speed adjustment: "Reduce/increase speed to one five zero."

Example: 250 TWO FIVE ZERO KNOTS
 185 ONE EIGHT FIVE KNOTS
 95 NINER FIVE KNOTS

6. Phonetic Alphabet

The International Civil Aviation Organization (ICAO) phonetic alphabet (Figure B-2) is used by FAA personnel when communications conditions are such that the information cannot be readily received without their use. Air traffic control facilities may also request pilots to use phonetic letter equivalents when aircraft with similar sounding identifications are receiving communications on the same frequency.

Pilots should use the phonetic alphabet when identifying their aircraft during initial contact with air traffic control facilities. Additionally, use the phonetic equivalents for single letters and to spell out groups of letters or difficult words during adverse communications conditions.

CHARACTER	MORSE CODE	TELEPHONY	PHONIC (PRONUNCIATION)
A	• —	Alfa	(AL-FAH)
B	— •••	Bravo	BRAH(-VOH)
C	— • — •	Charlie	(CHAR-LEE) or (SHAR-LEE)
D	— ••	Delta	(DELL-TAH)
E	•	Echo	(ECK-OH)
F	•• — •	Foxtrot	(FOKS-TROT)
G	— — •	Golf	(GOLF)
H	••••	Hotel	(HOH-TEL)
I	••	India	(IN-DEE-AH)
J	• — — —	Juliette	(JEW-LEE-ETT)
K	— • —	Kilo	(KEY-LOH)
L	• — ••	Lima	(LEE-MAH)
M	— —	Mike	(MIKE)
N	— •	November	(NO-VEM-BER)
O	— — —	Oscar	(OSS-CAH)
P	• — — •	Papa	(PAH-PAH)
Q	— — • —	Quebec	(KEH-BECK)
R	• — •	Romeo	(ROW-ME-OH)
S	•••	Sierra	(SEE-AIR-RAH)
T	—	Tango	(TANG-GO)
U	•• —	Uniform	(YOU-NEE-FORM) or (OO-NEE-FORM)
V	••• —	Victor	(VIK-TAH)
W	• — —	Whiskey	(WISS-KEY)

X	— • • —	Xray	(ECKS-RAY)
Y	— • — —	Yankee	(YANG-KEY)
Z	— — • •	Zulu	(ZOO-LOO)
1	• — — — —	One	(WUN)
2	• • — — —	Two	(TOO)
3	• • • — —	Three	(TREE)
4	• • • • —	Four	(FOW-ER)
5	• • • • •	Five	(FIFE)
6	— • • • •	Six	(SIX)
7	— — • • •	Seven	(SEV-EN)
8	— — — • •	Eight	(AIT)
9	— — — — •	Nine	(NIN-ER)
0	— — — — —	Zero	(ZEE-RO)

Figure B-2 Phonetic Alphabet

7. Common Terms

English is the international aviation language. Through the years, aviators and controllers have developed what is, at times, their own language. Several terms have been modified to fit the aviation environment. Here is a list of common aviation terms you will use throughout your career.

ACKNOWLEDGE

Let me know that you have received and understood my message

EXAMPLE: "[Call sign], _____ APPROACH, execute an immediate right turn heading 180, vector for traffic, acknowledge."

ADVISE INTENTIONS

Tell me what you plan to do.

EXAMPLE: "[Call sign], _____ TOWER, advise intentions after touch-and-go."

AFFIRMATIVE

Yes.

ALTITUDE RESTRICTION

An altitude or altitudes stated in the order flown which are to be maintained until reaching a specific point or time.

AT PILOT'S DISCRETION

ATC has offered the pilot the option of complying with the instruction whenever he/she wishes.

EXAMPLE: "[Call sign], _____ CENTER, descend at pilot's discretion and maintain one six thousand."

CLEARANCE LIMIT

The fix, point, or location to which an aircraft is cleared when issued an ATC clearance.

EXAMPLE: "[Call sign] is cleared to Navy Pensacola."

CLEARANCE ON REQUEST	Used by Clearance Delivery to inform the pilot that his clearance is being processed by ATC. EXAMPLE: "[Call sign], _____ CLEARANCE, your clearance is on request."
CLEARED AS FILED (also CLEARED VIA FLIGHT PLAN ROUTE)	Means the aircraft is cleared to proceed in accordance with the route of flight filed in the flight plan. This clearance does not include the altitude, SID, or SID transition. EXAMPLE: "[Call sign] is cleared to Navy Pensacola as filed (flight plan route). . ."
CLEARED	ATC authorization for an aircraft to perform a specific procedure (Approach, Land, Takeoff, etc.). EXAMPLE: "[Call sign], _____ TOWER, cleared to land RWY 14."
CLIMB UNRESTRICTED	Rate of climb to an assigned altitude is not restricted and/or published altitude restrictions on a SID are no longer applicable; however, the remaining items of the SID are binding. EXAMPLE: "[Call sign], _____ DEPARTURE, climb unrestricted to one one thousand."
CONCUR	I agree with you.
CONTACT	Establish communications with (followed by the name of the facility, and, if appropriate, the frequency to be used). EXAMPLE: "[Call sign], _____ CENTER, contact Pensacola Approach now on 270.8."
CORRECTION	An error has been made in the transmission and the correct version follows. EXAMPLE: " _____ CENTER, [Call sign], leaving niner thousand, correction eight thousand, for three thousand."
CROSS (FIX) AT/ABOVE OR BELOW	An altitude restriction at a specified fix is required.
DISCRETE FREQUENCY	A separate radio frequency for use in direct pilot controller communications.
DISREGARD	Cancel my last message.
EXECUTE	Perform a task. EXAMPLE: "[Call sign], _____ TOWER, execute missed approach."

EXPECT	Used under certain conditions to inform a pilot that an altitude/additional clearance will be provided later. EXAMPLE: "[Call sign], _____ DEPARTURE, expect seven thousand at Victoria."
EXPEDITE	To execute promptly. EXAMPLE: "[Call sign], _____ TOWER, expedite clearing runway."
FLY HEADING (DEGREES)	Informs pilot of heading he should fly. EXAMPLE: "[Call sign], _____ APPROACH, fly heading 290."
GLIDESLOPE/PATH	Used by ATC to inform an aircraft making a precision approach of its vertical elevation relative to descent profile. EXAMPLE: "[Call sign], above glidepath, correcting slowly."
GO AHEAD	Proceed with your message. EXAMPLE: "[Call sign], _____ CLEARANCE DELIVERY, I have your clearance. Advise ready to copy?" "[Call sign], go ahead."
GUARD	Guard frequency (243.0 MHz) is the universal emergency UHF frequency.
GO AROUND	Instructions for a pilot to discontinue his approach to landing. EXAMPLE: "[Call sign], _____ TOWER, obstruction on runway, go around."
HAND-OFF	An action taken to transfer the radar identification of an aircraft from one controller to another if the aircraft will enter the receiving controller's airspace and radio communications will be transferred.
HOW DO YOU HEAR/READ	A question relating to the quality of the transmission or to determine how well the transmission is being received. EXAMPLE: "[Call sign], _____ DEPARTURE, how do you hear (read)?"

IDENT	Request for a pilot to activate the aircraft transponder identification feature. This will help the controller to confirm an aircraft identity. (No verbal response necessary.) EXAMPLE: "[Call sign], _____ CENTER, ident."
IMMEDIATE	Used by ATC when such action is required to avoid a hazardous situation. EXAMPLE: "[Call sign], _____ DEPARTURE, immediate right turn heading 180."
INOPERATIVE	Used to describe a piece of equipment which has ceased to function properly; e.g., an inoperative TACAN.
INTERCEPT	To meet or cross. EXAMPLE: "[Call sign], _____ DEPARTURE, intercept the Crestview 230 radial and proceed inbound."
LAST ASSIGNED	Last clearance assigned by ATC and acknowledged by the pilot.
LEAVING	To depart an altitude/flight level at which you were level. EXAMPLE: "_____ APPROACH, [Call sign], leaving one zero thousand for six thousand."
MAINTAIN	Concerning altitude/flight level, the term means to remain at the altitude/flight level specified. The phrase "climb and" or "descend and" normally precedes "maintain" and the altitude assignment. EXAMPLE: "[Call sign], _____ APPROACH, descend and maintain two thousand two hundred." EXAMPLE: "Maintain VFR."
NOTE: Concerning other ATC instructions, the term is used in its literal sense.	
NEGATIVE CONTACT	Previous issued traffic is not in sight. EXAMPLE: "[Call sign], _____ APPROACH, you have T-47 traffic at your 12 o'clock at one mile, one six thousand." "[Call sign], negative contact."
MILITARY OPERATIONS AREA/MOA	Airspace assignment of defined vertical and lateral dimensions to separate certain military training activities from IFR traffic.
MISSED APPROACH	A maneuver conducted by the pilot when an approach cannot be completed to a landing.

NEGATIVE	"No" or "Permission not granted" or "That is not correct."
NEGATIVE CONTACT	Previous issued traffic is not in sight. EXAMPLE: "[Call sign], _____ APPROACH, you have T-47 traffic at your 12 o'clock at one mile, one six thousand." "[Call sign], negative contact."
NEGATIVE INFORMATION	Used by pilots to inform ATC that they have not received runway and wind information from ATIS. EXAMPLE: " _____ GROUND, [Call sign], taxi, negative information."
NO JOY	You were unable to contact ATC on a particular frequency.
NORDO	A contraction meaning "no radio." It is used to describe aircraft that have lost radio communication capability.
OUT	When said at the end of a transmission means: My transmission is ended; I expect no response. Should be used when it may not be apparent that no response is expected.
OVER	When said at the end of a transmission means: My transmission is ended, I expect a response. Should be used when it may not be apparent that a response is expected.
PASSING	Climbing or descending through an altitude/flight level. EXAMPLE: " _____ CENTER, [Call sign], passing eight thousand."
RECYCLE	Reset your transponder. Indicates that ATC is not properly receiving your IFF. EXAMPLE: "[Call sign], _____ CENTER, recycle transponder, Code 2321."
READ BACK	Repeat the message back to me. EXAMPLE: "[Call sign] is cleared . . . Departure 314.0, read back."
REPORT	Used to instruct pilots to advise ATC of specified information. EXAMPLE: "[Call sign], _____ APPROACH, report PENSI."

REQUEST	To ask for. EXAMPLE: " _____ APPROACH, [Call sign], request TACAN 13R approach to a full stop."
ROGER	I understand (not yes); acknowledges information. EXAMPLE: "[Call sign], _____ CENTER, surveillance radar is down at Navy Pensacola." "[Call sign], roger."
SAY AGAIN	Used to request a repeat of the last transmission.
SAY ALTITUDE	Used by ATC to ascertain an aircraft's specific altitude/flight level. When the aircraft is climbing or descending, the pilot should state the indicated altitude rounded to the nearest 100 feet. EXAMPLE: "[Call sign], _____ DEPARTURE, say altitude." "[Call sign], passing eight thousand two hundred."
SAY HEADING	Used by ATC to request an aircraft heading. The pilot should state the actual heading of the aircraft. EXAMPLE: "[Call sign], _____ APPROACH, say heading."
SEARCH AND RESCUE/SAR	Service which seeks missing aircraft.
SQUAWK	Activate specific modes/codes functions on the aircraft transponder. (No verbal response necessary unless you did not hear all four digits that were specified and want to confirm them.) EXAMPLE: "[Call sign], _____ CENTER, squawk code two-one-zero-zero." Example Codes: Emergency squawk 7700. Lost Comm 7600. VFR squawk 1200.
STAND BY	The controller or aircrew must pause for a few seconds, usually to attend to other duties of higher priority. Also means to "wait."
SWITCHING	A response to an ATC request to contact a new agency on a discrete frequency followed by reading back the frequency. EXAMPLE: "[Call sign], _____ CENTER, contact JAX Center now on 351.9." "[Call sign], switching 351.9."

TRAFFIC IN SIGHT	I have visual contact with other air traffic. EXAMPLE: "[Call sign], _____ DEPARTURE, traffic at your 12 o'clock and two miles, three thousand, type unknown." "[Call sign], traffic in sight."
UNABLE	Indicates inability to comply with a specific instruction, request, or clearance. EXAMPLE: " _____ APPROACH, [Call sign], unable to execute the ILS approach."
VECTOR	Heading issued to an aircraft to provide navigational guidance by radar. EXAMPLE: "[Call sign], _____ CENTER, turn left 090, vector for traffic."
VERIFY	Request confirmation of information. EXAMPLE: "Verify assigned altitude."
WILCO	I have received your message, understand it and will comply." EXAMPLE: "[Call sign], _____ GROUND, taxi runway 13L." "[Call sign], wilco."

8. Basic Formats

Adherence to the following guidelines will assist you in the application of proper radio communication:

- a. The format for contacting an agency is always, "Agency called, aircraft identification, message."

If at a loss for the "right" words, remember: WHO you are, WHERE you are, and WHAT you want.

- b. When instructed to squawk or ident on your IFF, no verbal response is necessary unless confusion exists.

Example: "[Call sign], _____ DEPARTURE, squawk 0622." (Dial Code 0622 in aircraft's IFF transponder.)

Example: "[Call sign], _____ DEPARTURE, IDENT." (Momentarily select the ident position on the transponder.)

- c. When advised to "contact" a new controlling agency, acknowledge with "switching" and repeat the specific frequency.

Example: "[Call sign], _____ DEPARTURE, contact Houston Center on 322.4."
"[Call sign], switching 322.4."

If unable to contact the new agency on the frequency given, return to the transferring agency and state, "No joy." The transferring agency will give you an alternate frequency to reattempt contact.

- d. Always report leaving an altitude. Unless requested, it is not necessary to report reaching an altitude.

Example: "[Call sign], _____ CENTER, climb and maintain FL210."
"[Call sign], leaving FL180 for FL210."

- e. When in a climb and instructed to climb to a new altitude (i.e., other than that issued in your clearance), you should acknowledge the new altitude.

Example: (you are passing 6000 for 9000 and Departure says):
"[Call sign], _____ DEPARTURE, climb and maintain 13,000."
"[Call sign], climbing to 13,000."

- f. When instructed to "report" a specific point or time of information, report only the item requested.

Example: "[Call sign], _____ APPROACH, report ROMEK."
"[Call sign], WILCO." (Upon reaching ROMEK): " _____ APPROACH,
"[Call sign], ROMEK."

Example: "[Call sign], _____ CENTER, say altitude passing."
"[Call sign], passing 5500."

- g. "Roger" nice-to-know information.

Example: "[Call sign], your clearance is on request."
"[Call sign], roger."

Example: "[Call sign], _____ DEPARTURE, radar contact."
"[Call sign], roger."

- h. "Wilco" instructions or commands which do not require a readback. You may wilco several commands with a single wilco.

Example: "[Call sign], proceed direct to MARYS, report reaching."
"[Call sign], wilco." (Covers two commands: 1) proceed MARYS, report MARYS.)

Or

"[Call sign], proceeding direct to MARYS, wilco" (Wilco covers the command not repeated; i.e., report IAF.)

- i. Mandatory readbacks include: headings, altimeter settings, leaving an altitude, and frequency assignments.

Example: "[Call sign], PENSACOLA DEPARTURE, turn left heading 180, descend and maintain one six thousand, altimeter 30.02."

"[Call sign], left 180, leaving FL210 for one six thousand, altimeter 30.02."

- j. Always acknowledge call-ups to your aircraft call sign. If you do not respond, the controller has no way of knowing whether you received the information or have experienced radio failure.

9. Summary

We have covered some of the procedures and terminology used during communications with ground controlling agencies. Proper utilization of this basic knowledge will enhance your abilities to successfully operate in the aviation environment in a professional manner.

APPENDIX C THE PRE-FLIGHT BRIEF

C100. AN OVERVIEW

The Pre-Flight Briefing Guide is a general purpose format used to discuss the majority of contingencies or emergency considerations that might arise in the course of a normal flight. Use of the Pre-Flight brief is not unique to the T-6B aircraft or to the Naval Air Training Command, but finds application in every aspect of Naval Aviation.

Preparing the Brief. The content of the brief includes those details relevant to communications, weather, navigation/flight planning and aircraft emergencies that are necessary for the safe and orderly conduct of a particular flight. Use the published briefing guide to organize the information you want to convey and amplify it as required.

No briefing is intended to be all-inclusive. Briefings should be tailored to the mission at hand; i.e., a briefing for a Formation hop would involve much additional detail that would not be relevant to a Contact briefing. Additionally, those missions that intend to take the aircraft into IMC weather would include crew coordination specifics that would not be covered in a Contact briefing except as a matter of contingency.

Crew Coordination. A fresh buzzword in Naval Aviation recently popularized because of the number of incidents or mishaps that have occurred without it and which could have easily been avoided with a little more of it. A professionally prepared Pre-Flight Brief is step one toward maximum crew coordination and efficient mission completion.

Use of Standard Operating Procedures. Reference to Standard Operating Procedures or published regulations is highly encouraged during briefings to avoid lengthy dissertations, provided that all members of the flight are thoroughly familiar with the procedures. The Pre-Flight Brief itself is founded on the premise of training and operations standardization for maximum combat readiness.

Any questions? An often overlooked, but perhaps most important, segment of the Pre-Flight briefing period which should be included in the conclusion of every brief. Use this period to clarify SOP or other details that may be pertinent to the assigned mission. The members of the flight that are being briefed should hold questions until the conclusion of the brief to the greatest extent possible. The enclosed pages are provided as an example or guide in preparing a Pre-Flight brief for Contact operations. It is admittedly wordy and intended for use with local Standard Operating Procedures.

The T-6B aircraft is inherently reliable. The odds of any one of these contingencies arising are slim, but with a proper Pre-Flight brief, you will be prepared to respond confidently and correctly should such a situation actually occur.

C101. THE BRIEFING

The brief should serve several functions. First, the brief should serve to inform all crewmembers about elements critical to safe mission completion. A briefing guide shall be used to prompt the briefer, but all items in the briefing guide will not apply to every mission. Items that do not apply may be passed over without mention. Those items which will be handled routinely in accordance with a published instruction may be briefed as such. Of particular importance to the Student Naval Aviator in this portion of the brief is the sequence of events or route of flight. Leave nothing to unspoken assumption; the instructor pilot expects his or her students to ask questions.

Just as important to dissemination of information in briefing, is the delineation of cockpit responsibilities. This function is the cornerstone of crew coordination. Put some serious thought into how tasks will actually be performed in normal and emergency conditions, then brief them as such. All crewmembers are responsible for ensuring that the flight conforms to existing limitations. Where the pilot in command does not specify stricter limits, existing SOP or the T-6B NATOPS Flight Manual always applies.

Another function of the brief is for the pilot in command to determine whether or not his crew is ready to fly. In the training command, the instructor pilot will evaluate a student's motivation and degree of readiness by checking the student's knowledge against standards established in the T-6B JPPT Curriculum.

For all flights, each student being graded shall check existing and forecast weather, and furnish the instructor with a grading sheet. The student shall bring a Master Curriculum Guide (MCG), Pocket Checklist, and all required charts and pubs to the brief. The flight shall be conducted as briefed. When circumstances require a change in plans, the pilot in command is responsible for updating the brief. When any crewmember is unclear with regard to any changes in plans, it is his or her responsibility to resolve any questions.